

# NOVAPLEX Vector

PROCESS DIAPHRAGM PUMPS



Part of SPX Corporation (NYSE: SPW), the Flow Technology segment designs, manufactures, installs and services highly engineered solutions used to process, blend, meter and transport fluids, in addition to air and gas filtration and dehydration. The segment supports the food and beverage, dairy, pharmaceutical, oil and gas, energy, and industrial markets worldwide.

Based in Charlotte, North Carolina, SPX Corporation (NYSE: SPW) is a global Fortune 500 multi-industry manufacturing leader with over \$5 billion in annual revenue, operations in more than 35 countries and over 14,000 employees. The company's highly-specialized, engineered products and technologies are concentrated in Flow Technology and energy infrastructure. Many of SPX's innovative solutions are playing a role in helping to meet rising global demand for electricity and processed foods and beverages, particularly in emerging markets. The company's products include food processing systems for the food and beverage industry, power transformers for utility companies, and cooling systems for power plants. For more information, please visit [www.spx.com](http://www.spx.com).

For more than 80 years, Bran+Luebbe – now a brand of SPX Flow Technology – has been providing customers with high quality metering, processing and analysing equipment.

As part of the global SPX Corporation, we are one of the world's most reputable manufacturers of metering and process pumps, process systems as well as analyzing technologies. Our engineers have comprehensive process and applications knowledge across a wide range of markets. This has resulted in product innovations and developments which harness the latest technology whilst meeting the highest quality standards.

## NOVAPLEX Vector

The Process Diaphragm Pump NOVAPLEX Vector combines a unique new gearbox design with well-proven diaphragm pump head technology and is ideally suited for applications in the oil&gas industry (onshore, offshore) as well in the chemical industry, offering a number of benefits, such as:

- Light weight
- Small footprint
- Easy maintenance due to reduced number of parts
- Less downtime
- Lower operation costs

### PERFORMANCE DATA

- **Volume / capacity:** 0.1 - 70 m<sup>3</sup> / hr\*
- **Pressure:** up to 400 bar (PTFE)  
up to 1000 bar (Metal)
- **Fluid temperature range:** -40 °C to +150 °C  
(special solutions upon request)
- **Ambient temperature range:** -40 °C to +60 °C  
(special solutions upon request)
- **Hazardous area:** up to Zone 1 IIC T4  
(Zone 22 upon request)
- **Adjustable capacity (VFD)**

\* Flow rate at 100% volumetric efficiency.

### ADDITIONAL FEATURES

- Diaphragm position control for maximum operating security
- Safe dry-run capabilities
- High volumetric efficiency
- Hermetically sealed by two diaphragm layers
- Diaphragm condition monitoring
- NOVALINK-CSM 2 Diagnosis interface as standard

### PERFORMANCE CHART

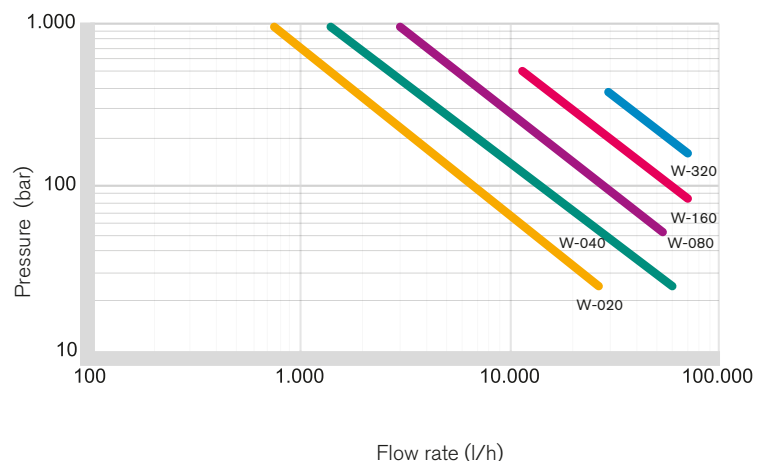

## TYPICAL MARKETS WITH APPLICATIONS

### ▪ Oil & Gas

- Methanol Injection
- Polymer Injection (**E**nhanced **O**il **R**ecovery)
- Hydrocarbon transfer
- and many more

### ▪ Chemical Processing Industry

- Reactor Feed
- and many more

### ▪ Mining

- Autoclave feed

## FLUIDS PUMPED (EXAMPLES)

- Ammonia
- Liquefied CO<sub>2</sub>
- Hydrocarbon Condensate
- Methanol, Glycol, Biocides
- LPG (Liquefied Petroleum Gas)
- Polymer
- Propionic Acid
- Raney Nickel suspensions
- Vinyl Chloride Monomer
- Vinyl Acetate Copolymer



## COMPACT GEAR DESIGN

- Small footprint
- Reduced weight
- Reduced maintenance effort

## ESTABLISHED PUMP HEAD TECHNOLOGY

- A pressure relief valve within the hydraulic system of the pump head protects the pump head itself as well as the pump gear from overload due to excessive pressure.
- Increased diaphragm life compared to non-positive control systems
- Diaphragm protection even under critical operating conditions
- Dry running capabilities
- Double-diaphragm pumps with diaphragm condition monitoring offer higher operation security than single diaphragm pump heads.

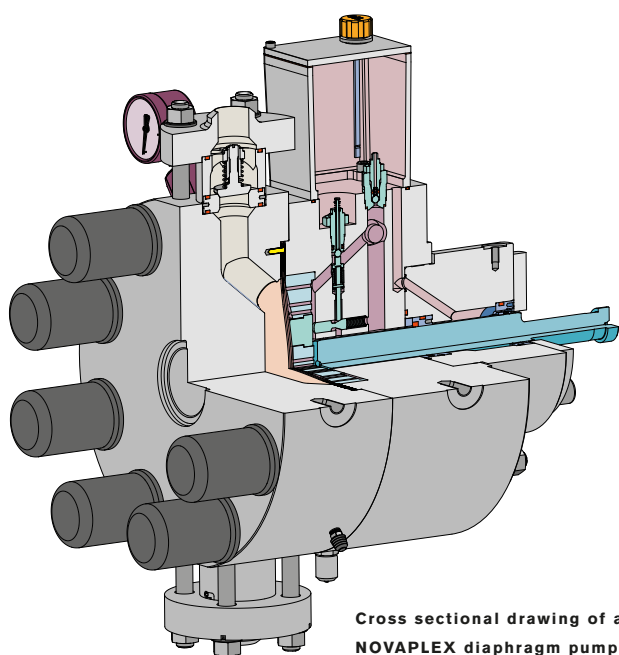

Cross sectional drawing of a  
NOVAPLEX diaphragm pump head

# NOVAPLEX Vector

PROCESS DIAPHRAGM PUMPS



**NOVAPLEX Classic**



**NOVAPLEX Integral**

In addition to the NOVAPLEX Vector pumps the NOVAPLEX *Classic* with externally mounted gear reducer, enabling an extended number of pump heads and the NOVAPLEX *Integral* with integrated gear reducer for minimized foot print are available for special projects.

## Global locations

### EMEA

#### SPX FLOW TECHNOLOGY

Werkstraße 4

D-22844 Norderstedt

Phone: +49 (0) 40 - 522 02 -0

Fax: +49 (0) 40 - 522 02 -444

E-Mail: [branluebbe@spx.com](mailto:branluebbe@spx.com)

### EMEA

#### SPX FLOW TECHNOLOGY

Ironstone Way

Brixworth, Northants, NN6 9UD

Phone: +44 (0) 1604 880751

Fax: +44 (0) 1604 880145

E-Mail: [ft.brixworth.sales@spx.com](mailto:ft.brixworth.sales@spx.com)

### EMEA

#### SPX FLOW TECHNOLOGY

P.O Box 299745,

Downtown Jebel Ali

The Galleries 4

Dubai, U.A.E.

Phone: +971 481 43400

E-Mail: [FT.Dubai.sales@spx.com](mailto:FT.Dubai.sales@spx.com)

### AMERICAS

#### SPX FLOW TECHNOLOGY

611 Sugar Creek Road

Delavan, WI 53115 USA

Phone: +1 (800) 252-5200 or

+1 (262) 728-1900

Fax: +1 (262) 728-4904

E-Mail: [branluebbe.americas@spx.com](mailto:branluebbe.americas@spx.com)

### AMERICAS

#### SPX FLOW TECHNOLOGY

Rua João Daprat, 231

São Bernardo do Campo

SP 09600-010 - Brazil

Phone: +55 11 2127 8278

Fax: +55 11 2127 8260

### APAC

#### SPX FLOW TECHNOLOGY

25 International Business Park

#03-03/12, German Centre,

Singapore 609916

Phone: +65 6568 1568

Fax: +65 6265 9133

E-Mail: [asia.pacific@spx.com](mailto:asia.pacific@spx.com)

### APAC

#### SPX FLOW TECHNOLOGY SHANGHAI OFFICE

1568 Hua Shan Road

5F Treasury Building

Changning District

Shanghai 20052 - PR China

Phone: +86 21 2208 5858

Fax: +86 21 2208 5866

E-Mail: [asia.pacific@spx.com](mailto:asia.pacific@spx.com)

For more locations please visit: <http://branluebbe.com>.

SPX reserves the right to incorporate our latest design and material changes without notice or obligation.

Design features, materials of construction and dimensional data, as described in this bulletin, are provided for your information only and should not be relied upon unless confirmed in writing. Please contact your local sales representative for product availability in your region. For more information visit [www.spx.com](http://www.spx.com).

"The green ">" is a trademark of SPX Corporation, Inc."