

# DELTA RUF3

## CHECK VALVE

Thanks to the high operational safety and compact design, the APV RUF3 non-return valve is used in places where return flow of product in pipelines must be avoided. This task is reliably achieved by the APV RUF3 valve. The valve is found in breweries and dairies as well as within the chemical and pharmaceutical industries.

### Characteristics

When the pressure is balanced, the valve starts closing by spring force so that it is also closed when the pressure on the spring side rises.

### Features and benefits

- Minimum flow resistance/pressure drop
- Smooth flow due to ball-shaped valve body
- Minimum response pressure at 0.05 bar
- Full opening cross-section at 0.08 bar
- Designed for CIP cleaning
- Soft seat seal
- Operation in horizontal or vertical position
- Intermediate flange design
- Special profile seals (eliminate gaps)
- APV RUF3 is designed for direct welding into process pipelines

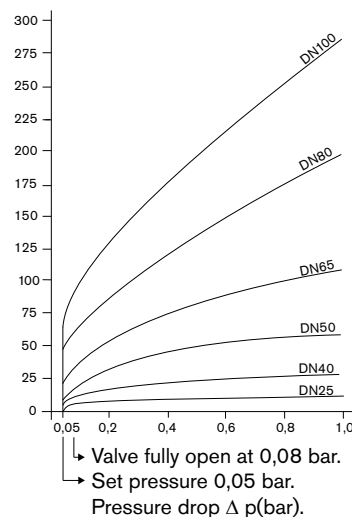
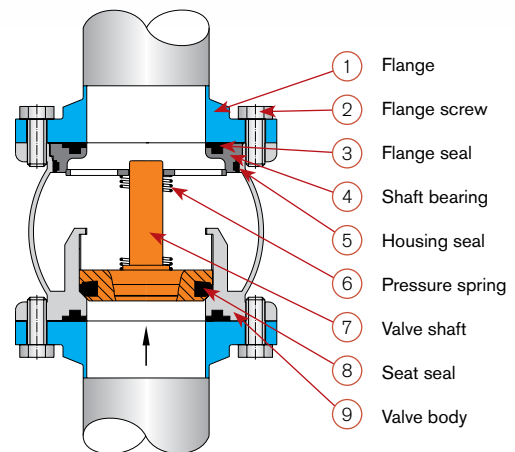

This diagram shows the flow characteristics depending on the pressure drop

### Technical data

Sizes	DN 25 – DN 150 and ISO 1" – 4"
Product wetted parts	316L, 1.4404 (DIN EN 100888)
Seal materials	EPDM, HNBR, VMQ or FPM All seal materials are FDA compliant.
Max. temperature	EPDM, HNBR: 135 °C - short-term: 140 °C VMQ, FPM : 135 °C - not suited for hot water and steam <b>Option:</b> FPM steam-resistant
Max. line pressure	10 bar

SPX Flow Technology Rostista, Zechenstrasse 49, D-59425 Unna, Germany  
Phone: +49 (0) 23 03/ 108-0 Fax: +49 (0) 23 03 /108-210



SPX reserves the right to incorporate our latest design and material changes without notice or obligation.

Design features, materials of construction and dimensional data, as described in this bulletin, are provided for your information only and should not be relied upon unless confirmed in writing. Please contact your local sales representative for product availability in your region. For more information visit [www.spx.com](http://www.spx.com).

The green ">" is a trademark of SPX Corporation, Inc..

APV-8017-GB Version: 02/2015 Issued: 06/2015

COPYRIGHT © 2008, 2015 SPX Corporation