

**Technische eigenschappen**

	Standaard	Opties
Technologie	Slangenpomp	
Capaciteit	15300 l/uur*	
Capaciteit per omwenteling	2,833 l/omw	
Aansluitingen	ISO PN16 flenzen	ISO PN20 / ANSI150 flenzen
Afmetingen	A 950 mm	
	B 825 mm	
	C 554 mm	
	D 164 mm	
	E 835 mm	
Gewicht	295-345 kg	

\* Alleen discontinu

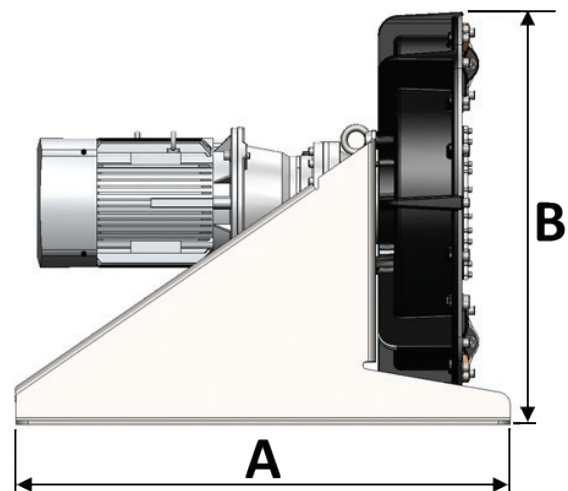
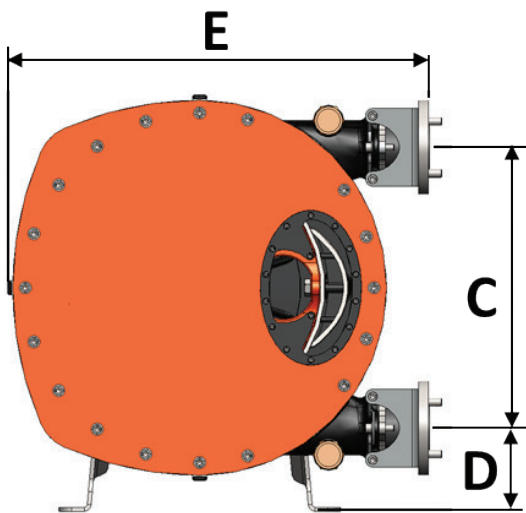

## Operationele limieten

	Standaard	Opties
Minimale temperatuur	0°C	
Maximale temperatuur	70°C	80°C met EPDM slang
Maximale viscositeit	40000 cSt	
Maximaal drukverschil	15 bar	
Maximale snelheid	90 omw/min*	
Maximale grootte vaste deeltjes	9 mm	
Maximale grootte zachte deeltjes	16 mm	

\* Alleen discontinu

## Materialen

#	Omschrijving	Standaard	Opties
1	Pomphuis	Nodulair gietijzer	
2	Deksel	Kolstofstaal	
3	Rotor	Nodulair gietijzer	
5	Schoen/nok	Nodulair gietijzer	
10	Deksel afdichting	NBR	
26	Asafdichting	NBR	
12	Insert	316L Roestvast staal	PPH, PVDF
16	Pompslang	NR	NBR, NBR-FDA, EPDM, Hypalon
18	Bracket	Verzinkt staal	
21	Frame	Verzinkt staal	
	Bouten, schroeven en ringen	Verzinkt staal	
25	Kijkglas	Polycarbonaat	

