



Manufacturer: -  
**BARTON FIRTOP ENGINEERING COMPANY LIMITED**  
 Silverwoods Way,  
 Kidderminster, Worcestershire. DY11 7DT,  
 ENGLAND  
 Telephone: (44) 01527 831644  
 Fax: (44) 01527 832638  
 E-mail: sales@bartonfirtop.co.uk

Data Sheet Number:  
**SDD/MBC/R300/STL**  
 Revision: **07**

## R/F - 300LB RATING BOLTED COVER MONO-IN-LINE STRAINER

**Sizes:** 1" to 12" Nominal Bore

**Pressure:** ASME Class 300LB

- Features:**
- Integrally Cast Housing
  - Bolted Cover
  - Integral Flanged Drain & Vents
  - Red Oxide Finish as Standard
  - 3mm Perf. Basket as Standard
  - Integral feet on 6" and over

- Options:**
- Special Gasket, Special Basket
  - Blind Flange / Plugged
  - D.P. Tappings / Gauge
  - Magnetic Basket Insert
  - Drain / Vent Valves
  - Special Finish / Linings
  - PN40 Flanges

**Standards:** PED 2014/68/EU (CE / UKCA)  
 Generally I.A.W. ASME VIII Div.1  
 ASME B16.5 Flange Dimensions  
 EN 10204 / NACE Certification

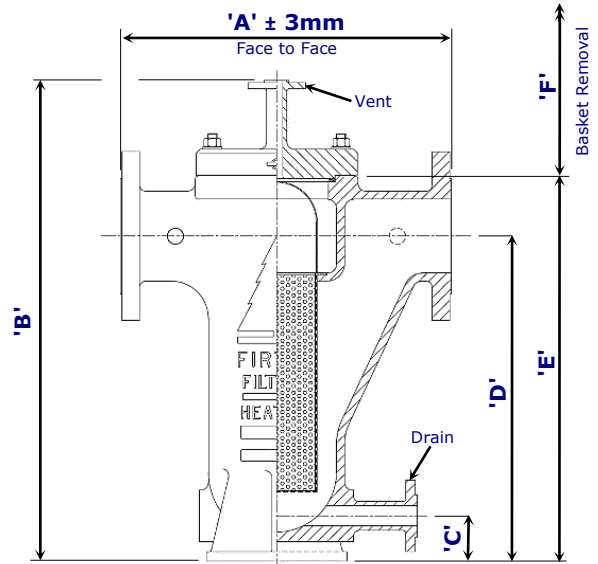

All data is subject to confirmation at the time of order. Our policy is one of continual improvement and we reserve the right to amend details without prior notice.

Note, bottom of drain flange is lower than the base on strainers without feet (1"NB to 4"NB).

Size		Dimensions						Basket Area (cm <sup>2</sup> )	Vent (NB)	Drain (NB)	Weight (KG)
		'A' Face to Face	'B' Base to Vent	'C' Base to Drain	'D' Base to Centreline	'E' Base to Top Head	'F' Basket Removal				
Inch	mm										
1"	25	232.0	325.0	27.5	190.0	226.0	200.0	241.0	¾"	¾"	14.0
1½"	40	245.0	397.0	28.5	254.0	297.0	275.0	375.0	¾"	¾"	20.5
2"	50	321.0	463.0	38.0	314.0	362.0	340.0	488.0	¾"	¾"	27.5
3"	80	375.0	514.0	38.0	342.0	411.0	375.0	652.0	¾"	¾"	47.0
4"	100	455.0	616.0	49.0	426.0	509.0	450.0	1088.0	¾"	1"	82.0
6"	150	620.0	903.0	95.0	619.0	747.0	630.0	2151.0	¾"	1½"	200.0
8"	200	740.0	1114.0	109.5	787.0	949.0	800.0	3973.0	¾"	1½"	360.0
10"	250	890.0	1273.0	120.0	908.0	1100.0	940.0	5304.0	¾"	1½"	535.0
12"	300	1050.0	1542.0	175.0	1152.0	1364.0	1180.0	8295.0	¾"	2"	910.0

Materials of Construction		
Item	Carbon Steel	Stainless Steel
Strainer Body (Cast)	ASME SA216 WCB	ASME SA351 CF8M
*Strainer Cover	ASME SA516 Gr60 / A216 WCB	ASME SA240 316 / SA351 CF8M
Strainer Basket	ST.ST. 316 (3mm Perf. as Standard / to Customer Specification)	
Cover Gasket	C.N.A.F. as Standard / to Customer Specification	
Cover Studbolts	ASME SA193 B7M - Zinc Plated	
Cover Full Nuts	ASME SA194 2HM - Zinc Plated	
Cover Washers	Carbon Steel - Zinc plated	
Cover Eyebolts	Carbon Steel C15E - Zinc Plated (if Applicable)	

\* The Strainer cover may be furnished from plate or casting depending upon size / availability.

### Model Number Derivation: -

The model number can be derived as follows: - **A\*\*\*/R30/\*\*\*/MBC**

Denotes the size i.e. add '025' for a 1" \_\_\_\_\_ '216' denotes Carbon Steel  
 '351' denotes Stainless Steel

For more information, visit our Web Site: [www.bartonfirtop.co.uk](http://www.bartonfirtop.co.uk)