

High Efficiency Tower Clean Systems

Automatically Keep Cooling Tower Basins Clean



FLOW RATES:

Basin Sweeping: 50 – 910 US gpm (11 – 206 m³/hr)

Side Stream: 65 – 810 US gpm (15 – 184 m³/hr)

Maximum Pressure Rating: 150 psi (10.3 bar)

Maximum Fluid Operating Temperature: 100°F (37.8° C)

Contact factory for high temperature models

LAKOS High Efficiency eTCX Tower Clean Systems help keep the cooling tower basin free of suspended solids that cause scale, corrosion, fouling and biological activity.

Controlling these factors leads to lower maintenance, improved chemical effectiveness, longer cooling tower and downstream equipment life, and a significant decrease in long-term water and energy costs.

eTCX Features and Benefits:

- 99% filtration efficiency of solids down to 25 micron (2.6 Specific Gravity) and larger greatly reduces suspended solids in recirculated cooling tower water; significantly improving equipment life and removing food source for biological activity
- Minimize tower nozzle clogging, protect basin floor from under-deposit corrosion, eliminate risk of injury associated with manual basin cleaning, and greatly reduce heat transfer loss in downstream equipment
- Control panel supports both Solids Recovery Vessel (SRV) and Automated Purge (EFS/ABV) allowing users the option to convert their system from an SRV to ABV/ EFS - Eliminating the need to change the control panel.
- NEMA Premium 1750RPM TEFC motor provides superior efficiency, greater returns on investment, and meets most urban noise abatement levels
- Electric fail-safe valve (EFS) eliminates manual purging and automatically closes valve in event of power failure
- eHB HydroBooster water nozzles operate as low as 10psi. 50% less psi than our standard HydroBoosters; reducing need for larger pumps
- Solids Recovery Vessel (SRV) offers zero water loss and helps meet waste/chemical disposal requirements. eTCX System features SRV-833 - a larger SRV allowing for fewer bag changes

FILTRATION APPLICATIONS:

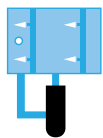

Basin Sweeping

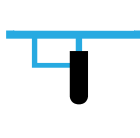

Side Stream



Closed Loop

WATER USAGE



Zero Water Loss
Options Available

SOLIDS METER

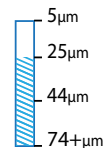

Micron Removal
µm (microns)

MAINTENANCE



Zero
Maintenance
Options Available

High Efficiency Basin Sweeping

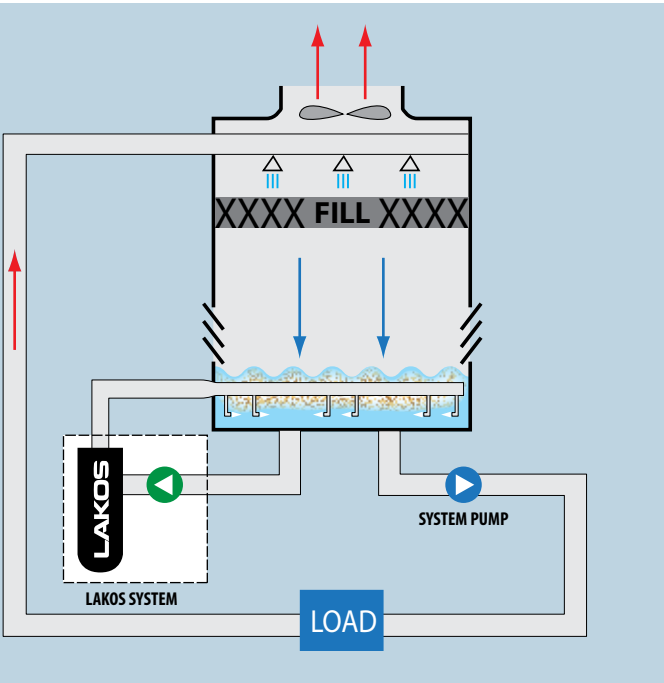
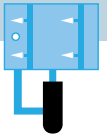

Traditional side stream filtration systems take a percentage of the flow (generally 10-25% or less) from the main line using a by-pass directly to the filtration system. The filtered water is then returned to the main line. Basin sweeping is simply relocating the traditional side stream filtration system from the main line directly to the cooling tower basin, thus increasing the percentage of side stream filtration to 20% or more.

Additional advantage is gained by recirculating the filtered water through a network of pipes and nozzles that sweep and direct other settled and suspended solids from the basin towards the filtration system – and away from the condenser water pump.

Basin sweeping capacity is determined by the volume of water in the basin rather than assigning a percentage of the full flow, as is commonly done with traditional side stream applications.

ADVANTAGES OF eTCX SYSTEM

AVERAGE SYSTEM PUMP POWER REDUCTION

eTCX Systems	28.5%	28.5% Less Energy Required
TC Systems		

AVERAGE SYSTEM NOISE REDUCTION (dB comparison)

eTCX Systems	79.8%	79.8% Less Noise
TC Systems		

AVERAGE SYSTEM PUMP POWER REDUCTION (per US gpm)

eTCX Systems	34.4%	34.4% Pump Power Reduction (P/gpm)
TC Systems		

AVERAGE SYSTEM kW REDUCTION

eTCX Systems	29.7%	29.7% Decrease in system kW consumption
TC Systems		

Ask us about our ROI Calculator

Solids Removal Chart: Recirculated flow at 20% Side Stream

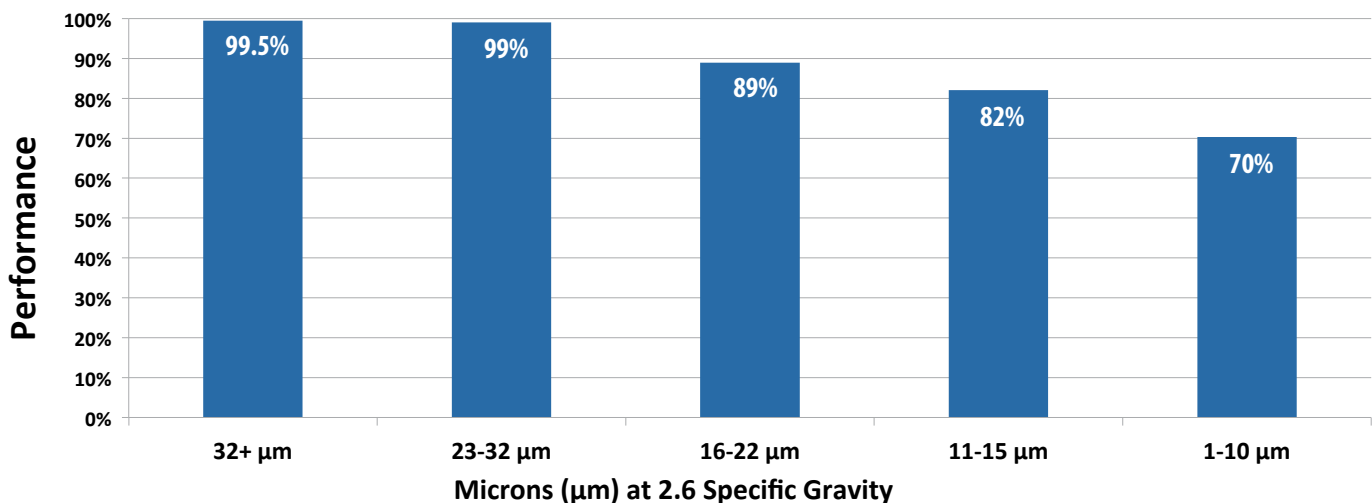

The above efficiency results were based upon 20% side stream within 16 hours. Field results may vary depending on side stream percentage and basin size. Performance results verified by independent testing.

eHB HydroBoosters™

eHB HydroBoosters operate at 10psi.
50% less than our standard HydroBoosters

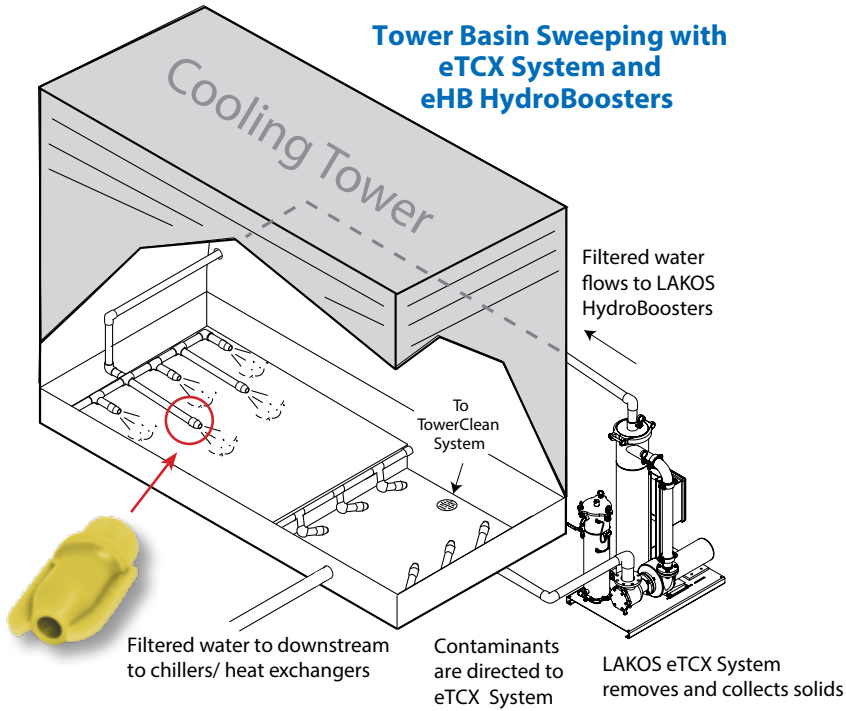

6x induced flow rate activity

1 US gpm enters HydroBooster



HydroBoosters in action

Directed turbulence maximizes cleaning efficiency in the tower basin/remote sump. LAKOS eHB HydroBoosters provide that turbulence with patented vortexing action. Consult LAKOS for technical assistance in basin sweeping layout and piping options.

Basin Cleaning in a Factory Packaged Tower



TC Systems in Aulani Disney Hawaii Resort, Hawaii USA

Basin Sweeping in a Field Erected Tower



HydroBooster Layout at Roseburg Forest Products, California USA

Installation Best Practices

- Start with a clean basin.
- Required submergence of 2" above centerline inlet of HydroBoosters.
- Position the HydroBoosters to direct solids toward the filtration system's pump intake and away from any other system pump suction areas.
- Use a closed-loop header in order to equalize the pressure to each HydroBooster.
- Eliminate weirs, baffles or other devices which may promote settling or dead spots within the sump.
- Where possible, take advantage of any existing slopes to direct solids toward the low end of a sump.
- When possible, position the system's pump intake where solids are most likely to enter the sump.

LAKOS Separators & Systems must be installed downstream of the main System Pump. Do not install on the suction side of the main system pump. Flow must be pushed through the separator and not pulled. Consult LAKOS for questions.

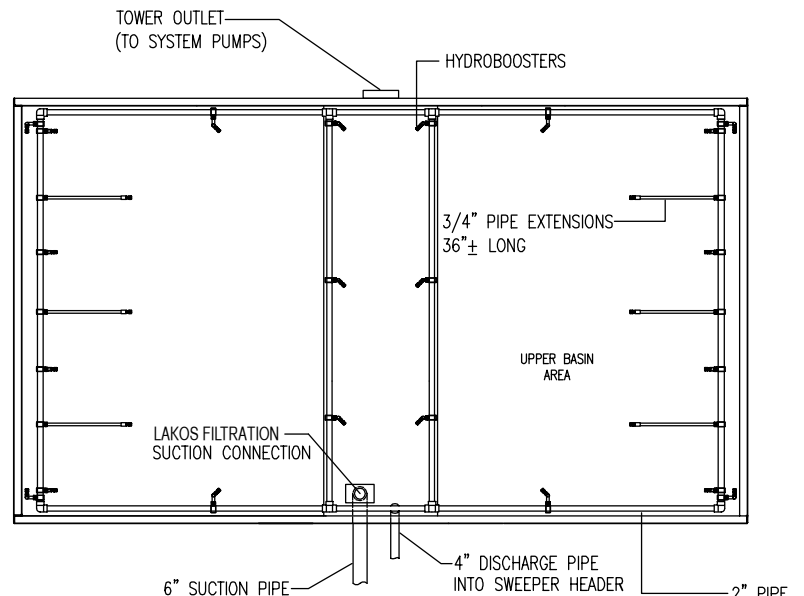

Dual Tower Switching for Light Solids Loading

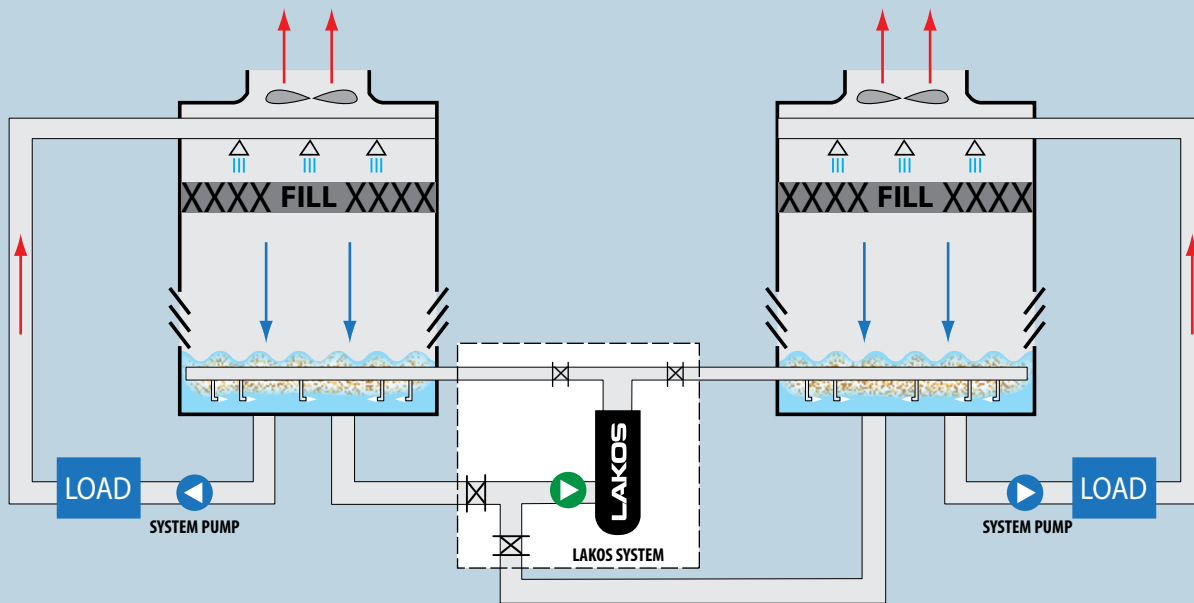

LAKOS recommends one eTCX basin sweeping system per cell for maximum energy savings and reduced life-cycle costs.

When short term budget needs demand, eTCX systems also provide the benefit of filtering two cooling tower cells alternately – without operator input.

Alternating Kit Features and Benefits:

- Provides primary and stand-by tower filtration
- Use one filtration system to clean two cooling tower cells alternately. Economical basin sweeping solution for applications with light solids loading
- Utilized when filtration requirements have larger horsepower (HP) needs and the environment is such that it will allow for smaller HP systems to alternate between cells
- Automated valve switching operation eliminates manual switching in dual cell tower configurations



LAKOS Multi-Tower Basin Cleaning Control Panel
NEMA4x Enclosure



Actuator/Valve Assemblies

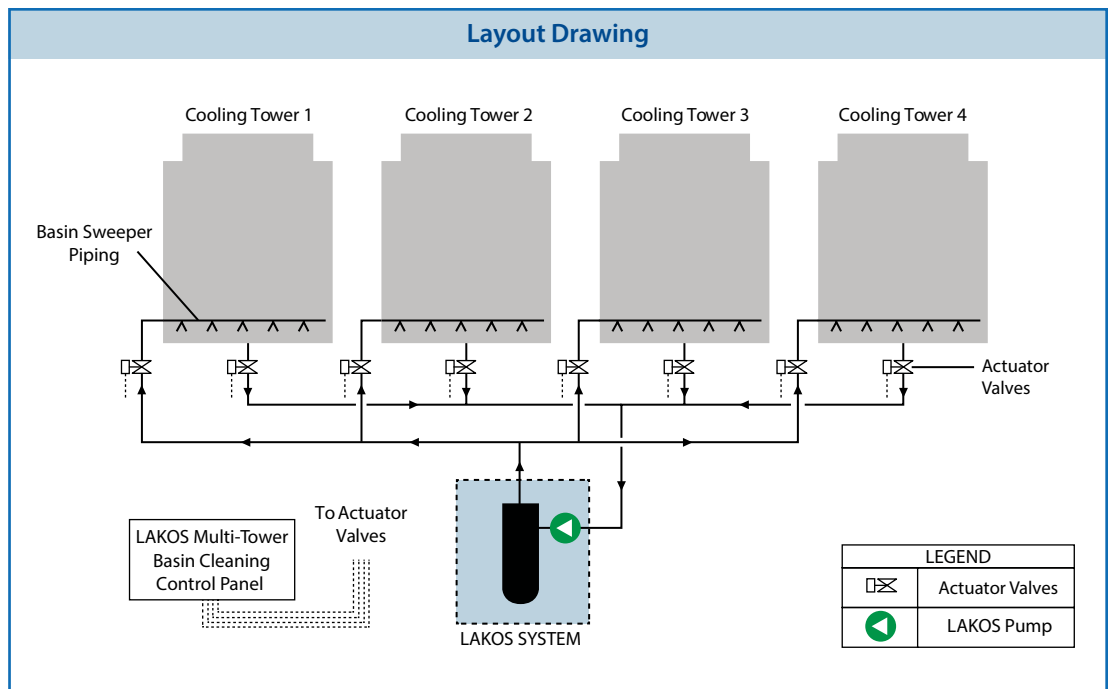

1. All wiring, conduit, and fittings from the control panel to the actuator/valve assemblies to be sized and provided by others. 2. Multi-Tower Basin Cleaning control panel is powered separately from the LAKOS Filtration system.

Solids Recovery Vessel (SRV)

Features and Benefits:

- Capture separated solids easily and return clean liquid back to eTCX pump suction; eliminating liquid loss
- Continuous operation; remove collected solids without interrupting system flow for service
- Lower waste treatment costs, meet waste disposal requirements and greatly reduce chemical loss
- Optional dry contact available for remote monitoring with BMS (Building Management System) connection or audio/visual alarms for bag changes
- For more information see LAKOS literature LS-622



SRV-833

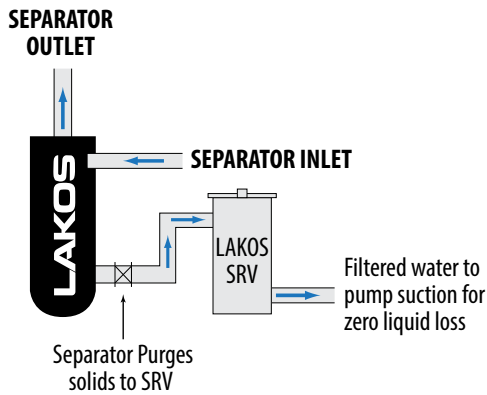

Solids Recovery Vessel (SRV) helps capture separated solids from LAKOS Separators – and return clean liquid back to the system through pump suction for zero liquid loss

Electric Fail-Safe Valve (EFS)

Features and Benefits:

- Battery backup electric fail-safe option automatically closes valve in event of power failure
- Eliminates manual purging
- EFS actuator features an electronic circuit that automatically adjusts the motor speed (depending on torque variations) to keep cycle time constant – maintaining consistent purge durations
- EFS actuator housing is made of a V0 self-extinguish class techno-polymer material for fire safety
- Can be combined with an SRV to offer temporary hands-off operation
- For more information see LAKOS literature LS-913



EFS

Models	Valve Diameter	
	inches	mm
EFS-07	3/4"	19.05
EFS-15	1-1/2"	38.1

Purge controller is required and included as part of valve kit.

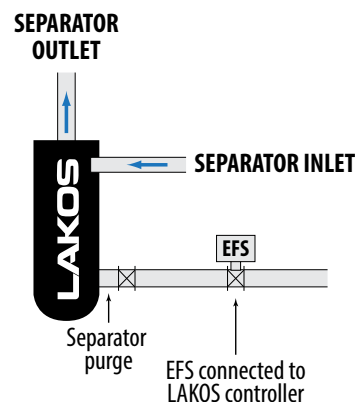

EFS and LAKOS Controller automatically purge separated solids from Separator's collection chamber at pre-determined time intervals – eliminating manual purging.

High Efficiency Side Stream and Closed Loop Cleaning

Side Stream

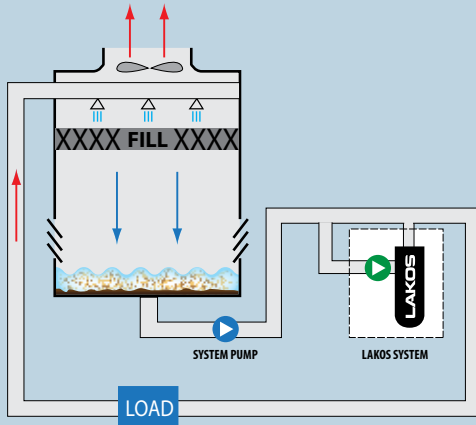

BENEFITS:

- Economical filtration solution
- Large or variable flow application where full flow is not an option and basins are not accessible
- Reduce suspended solids in main line flow
- Easy to retrofit
- Zero liquid loss options with LAKOS Solids Recovery Vessel
- Zero filtration maintenance when using LAKOS automated purge valves

Closed Loop

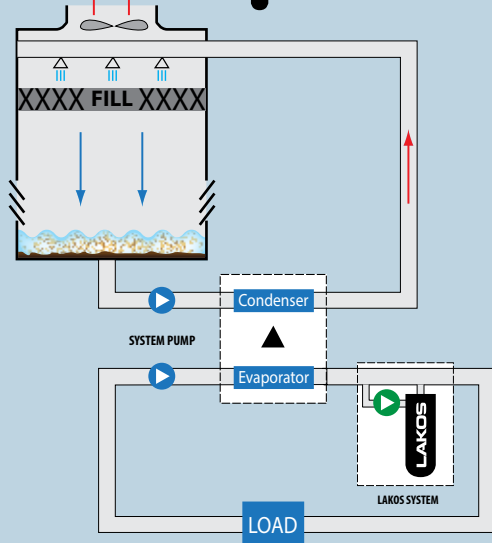

BENEFITS:

- Side stream filtration to remove solids generated in closed loops
- Zero liquid (water or coolant) loss with Solids Recovery Vessel
- Direct replacement for side stream bags or spiral wound cartridges



Side Stream Filtration, Parkland Hospital, Texas USA



Closed loop Filtration, Data Center, Virginia USA

Inlet/Outlet Premium Butterfly Valve Kits

Model	Inlet Valve Sizes	Outlet Valve Sizes
eTCV models	2.5" to 8" Flanged Butterfly Valves	1.25" to 4" Butterfly Valves 1.25" and 1.5" models are NPT ball valves

HydroBoosters™

Model	Connection Size	Extension Pipe Size (minimum)	Input Flow	Input PSI
eHB	½" (12.7mm) male NPT	¾" (19.05mm)	10 US gpm (2m³/hr)	10 psi

NOTE: These flow rates are based on an input pressure of 10psi (.68 bar). Minimum water level above centerline of HydroBooster should be 2 inches (50.8 mm).

Models & Dimensions

Basin Sweeping Model Selection

After determining the basin size using the formula to the right, refer to the flow rate column below.

Select a model that has an equal or larger flow rate. Flow rates larger than those below are available. Please consult LAKOS.



Since active and directed circulation of basin/sump liquid is required for effective solids removal, model selection for the LAKOS eTCX System is based upon the size of the basin or remote sump. This is best determined with these calculations:

For Packaged Cooling Towers

$$\text{Flow Rate} = \text{Length of Basin (feet)} \times \text{Width of Basin (feet)} \times 1 \text{ gpm/ft}^2 = 2.44 \text{ m}^3/\text{hr/m}^2$$

For Remote Sumps with Water Depth Greater than 3 ft**

$$\text{Flow Rate} = \text{Length of Basin (feet)} \times \text{Width of Basin (feet)} \times 1.5 \text{ gpm/ft}^2 = 3.66 \text{ m}^3/\text{hr/m}^2$$

Basin Sweeping Configuration

Flow Rate = Basin square footage												
Models	eHTX Separators	Flow Rates ¹		Diffuser/Strainer inlet ⁴	Separator outlet	System Weight		Pump HP/kW ²	Full Load Amperage ³			
		US gpm	m ³ /hr			lbs	kgs		208V	230V	460V	575V
eTCX-0050-SRV	eHTX-0025	50	11	2-1/2"	1-1/4"	558	264	2 HP/1.48 kW	5.6	5.1	2.52	2.1
eTCX-0080-SRV	eHTX-0040	80	18	2-1/2"	1-1/2"	568	257	3 HP/2.23 kW	8.3	7.5	3.9	3.1
eTCX-0110-SRV	eHTX-0060	110	25	3"	2"	683	309	3HP/2.23 kW	9	8.4	4.2	3.4
eTCX-0160-SRV	eHTX-0080	160	36	4"	2-1/2"	832	377	5 HP/3.72 kW	13.9	13.4	6.7	5.4
eTCX-0210-SRV	eHTX-0090	210	48	4"	3"	875	396	7.5 HP/5.59 kW	21	19	9.3	7.5
eTCX-0310-SRV	eHTX-0140	310	70	6"	4"	1109	502	7.5 HP/5.59 kW	21	18.8	9.4	7.5
eTCX-0410-SRV	eHTX-0185	410	93	6"	4"	1233	555	10 HP/7.45 kW	25.4	24	12	9.6
eTCX-0610-SRV	eHTX-0260	610	138	6"	4"	1859	845	20 HP/14.8 kW	50.9	46	23	18.4
eTCX-0910-SRV ⁵	eHTX-0320	910	206	8"	6"	2493	1133	25 HP/18.7 kW	66	60	30	24

Side Stream and Closed Loop Configuration

Flow Rate is critical to system performance. Select model based on Side Stream Flow Rates. LAKOS recommends 20% Side Stream												
Models	eHTX Separators	Flow Rates ¹		Diffuser/Strainer inlet ⁴	Separator outlet	System Weight		Pump HP/kW ²	Full Load Amperage ³			
		US gpm	m ³ /hr			lbs	kgs		208V	230V	460V	575V
eTCX-0050-SRV	eHTX-0025	65	15	2-1/2"	1-1/4"	558	267	2 HP/1.48 kW	5.6	5.1	2.52	2.1
eTCX-0080-SRV	eHTX-0040	95	22	2-1/2"	1-1/2"	568	257	3 HP/2.23 kW	8.3	7.5	3.9	3.1
eTCX-0110-SRV	eHTX-0060	140	32	3"	2"	683	309	3HP/2.23 kW	9	8.4	4.2	3.4
eTCX-0160-SRV	eHTX-0080	210	48	4"	2-1/2"	832	377	5 HP/3.72 kW	13.9	13.4	6.7	5.4
eTCX-0210-SRV	eHTX-0090	250	57	4"	3"	875	396	7.5 HP/5.59 kW	21	19	9.3	7.5
eTCX-0310-SRV	eHTX-0140	365	83	6"	4"	1109	502	7.5 HP/5.59 kW	21	18.8	9.4	7.5
eTCX-0410-SRV	eHTX-0185	450	114	6"	4"	1233	555	10 HP/7.45 kW	25.4	24	12	9.6
eTBX-0610-SRV	eHTX-0260	610	138	6"	4"	1644	747	10 HP/7.45 kW	25.4	24	12	9.6
eTBX-0810-SRV ⁵	eHTX-0320	810	184	8"	6"	2227	1012	15 HP/11.2 kW	41	37	18.5	14.8

NOTES: All eTCX models are available in PLUS system configurations for filtration down to .35 microns.

¹ Higher flow rates available. Contact LAKOS.

² Models 0050 and 0080 use 3500RPM.

³ Contact LAKOS for motor specific FLA.

⁴ Minimum suction pipe size is equivalent to system's diffuser inlet. Pump NPSHR and piping to-and-from LAKOS Systems should be reviewed and sized accordingly. Consult LAKOS for design assistance if length of suction line is more than 25' or has several elbows or elevation changes.

⁵ eTCX-0810 and eTBX-0810 units are 22 1/2 deg. low profile

Dimensions

Models	Dim A		Dim B		Dim C	
	inches	mm	inches	mm	inches	mm
eTCX-0050-SRV	24	610	39-3/4	1010	38-15/16	989
eTCX-0080-SRV	29-1/2	749	45	1143	45-1/4	1149
eTCX-0110-SRV	29-1/2	749	45	1143	50-11/16	1287
eTCX-0160-SRV	29-1/2	749	45	1143	59-1/2	1511
eTCX-0210-SRV	29-1/2	749	45	1143	66-11/16	1694
eTCX-0310-SRV	31-1/2	800	45	1143	76-5/8	1946
eTCX-0410-SRV	31-1/2	800	45	1143	82	2083
eTCX/eTBX-0610-SRV	36	914	49-3/4	1264	95-1/2	2426
eTCX/eTBX-0810-SRV	46-1/2	1181	123-3/4	3143	67-1/2	1715

Dimensions are for spatial considerations only. Do not pre-plumb based on above dimensions. Contact factory for detailed dimensions.

More detailed CAD drawings and CSI specifications are available at LAKOS.com.

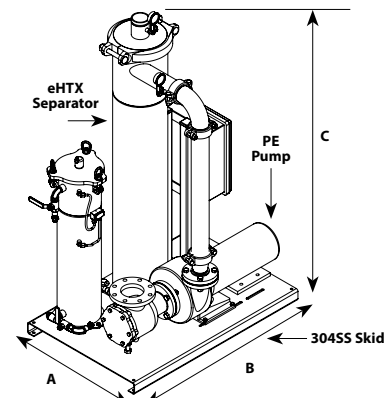

Independent Testing



LAKOS Separators have been independently tested and certified by an independent testing agency, the International Center for Water Technology (ICWT), confirming our separators' filtration performance and capability to remove troublesome particle matter from pumped water.

For over 30 years the internationally recognized ICWT/CIT Testing Laboratories have been providing independent, third party testing to a wide range of irrigation and other industries around the world.

ICWT has experience with hydraulics, pumps, filters, and valves. Fluid component testing provides manufacturers, distributors and end-users with accurate performance data for applicability assessment and enable product development. ICWT was recently certified by IAPMO R&T - North America's premier third party certification body for plumbing and mechanical products. More information about the testing agency and testing process can be found at www.californiawater.org.

Limited Warranty

This product series is warranted to be free of defects in material or workmanship, given the following terms:

LAKOS Separator: 5 years

All other components: 12 months from date of installation; if installed 6 months or more after ship date, warranty shall be a maximum of 18 months from ship date.

If a fault develops, notify us, giving a complete description of the alleged malfunction. Include the model number(s), date of delivery and operating conditions of subject product(s). We will subsequently review this information and, at our option, supply you with either servicing data or shipping instruction and returned materials authorization. Upon prepaid receipt of subject product(s) at the instructed designation, we will then either repair or replace such product(s), at our option, and if determined to be a warranted defect, we will perform such necessary product repairs or replace such product(s) at our expense.

This limited warranty does not cover any products, damages or injuries resulting from misuse, neglect, normal expected wear, chemically-caused corrosion, improper installation or operation contrary to factory recommendation. Nor does it cover equipment that has been modified, tampered with or altered without authorization.

No other extended liabilities are stated or implied and this warranty in no event covers incidental or consequential damages, injuries or costs resulting from any such defective product(s).

LAKOS Corporation, headquartered in Fresno California since 1972, is recognized worldwide for engineering, manufacturing and marketing the original centrifugal action solids from liquids separator and being the world-wide leader in cyclonic separation technology.

LAKOS Separators are manufactured in the USA. 

eTCX system components are warranted for one (1) year from date of delivery. If installed 6 months or more after ship date, warranty shall be a maximum of 18 months from ship date. eHTX separators are warranted for five (5) years from date of delivery. For detailed warranty information visit <http://www.lakos.com>

LAKOS Separators are manufactured and sold under one or more of the following U.S. Patents: 5,320,747; 5,338,341; 5,368,735; 5,425,876; 5,578,203; 5,622,545; 5,653,874; 5,894,995; 6,090,276; 6,143,175; 6,167,960; 6,202,543; 7,000,782; 7,032,760 and corresponding foreign patents, other U.S. and foreign patents pending.

LAKOS® and HydroBoosters™ are trademarks of LAKOS Corporation

LAKOS is a proud and contributing member of ASHRAE for over 30 years

LS-910I (Rev. 2/21)



1365 North Clovis Avenue
Fresno, CA 93727

www.lakos.com

Tel: (559) 255-1601

info@lakos.com