

EK KNIFE GATE VALVE

The EK model knife gate valve is a high-performance wafer type valve designed for general industrial service applications. The design of the body and seat assures non-clogging shut off on suspended solids in industries such as Pulp and Paper, Waste Treatment Plants, Food & Beverage, Mining, Power Plants, Chemical Plants, Bulk Handling, etc

Product description:

- Uni-directional wafer type high-performance knife gate valve
- Size range of DN50-1200 (larger sizes upon request). See Dimension Charts for pressure rating
- Non-rising stem
- Standard flange connection: DIN PN10 (EN 1092-2) and ANSI B16.5 (class 150)
Others available upon request
- Manual (handwheel, chainwheel, lever and bevel gear), pneumatic (single and double-acting), electric and hydraulic actuation options available
- Directives: 2006/42/EC (MACHINES), 2014/68/EU (PED) Fluid: Group 1(b), 2 (Cat. I. mod. A) and 2014/34/EU (ATEX)

Features:

- Wafer cast monoblock body with internal cast-in gate wedges and guides for tighter shut-off
- Full port design for greater flow capacity and minimal pressure drop
- Stainless steel gate polished both sides to avoid jamming and seat damage
- Cast stainless steel seat ring, easily replaceable, that mechanically locks the seal. Standard EPDM seat, also available in other materials (PTFE,...). Metal-to-metal seat and deflection cones available
- Long-life multiple graphite impreg. PTFE/aramid yarn combination with elastomeric core, EPDM o-ring, packing with easy access and adjustable gland follower. Wide range of materials available
- RAL-5015 blue epoxy-coating on all cast iron/carbon steel components
- Automated valves provided with gate guards in accordance with EU Safety Standards
- Other options: bonnets, V-ports, flush ports, special materials, fabricated valves, etc.
- Actuation accessories: limit & proximity switches, mechanical stops, positioners, solenoid valves, manual overrides, locking devices, fail safe systems, stem extensions and floor stands

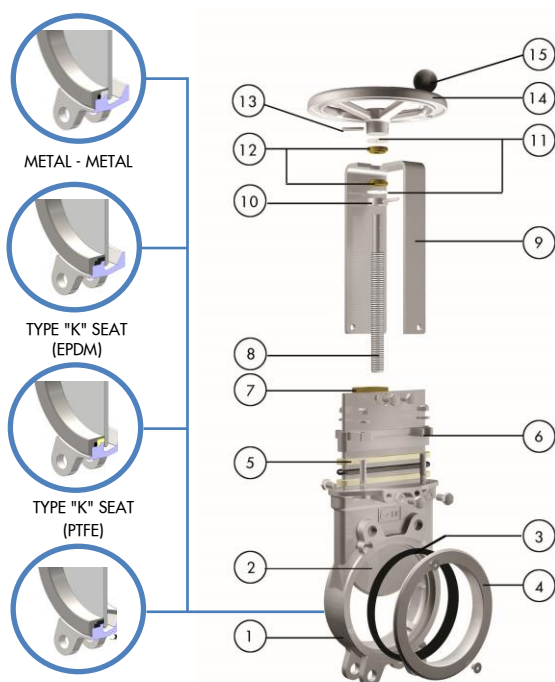
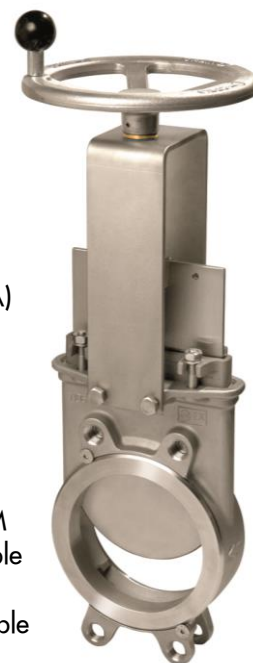

STANDARD PARTS LIST

Part	Stainless Steel
1 Body	CF8M (1.4408)
2 Gate	AISI 316 (1.4401)
3 Seat	EPDM
4 "K" Ring	CF8M (1.4408)
5 Packing	Dynapack + EPDM O-ring
6 Gland Follower	CF8M (1.4408)
7 Stem Nut	Brass
8 Stem	Stainless Steel
9 Yoke	AISI 304 (1.4301)
10 Axial Fixing Bush	AISI 304 (1.4301)
11 Friction Washer	PET + solid lubricant
12 Bushing	Bronze
13 Spring Pin	AISI 420 (1.4021) (ISO 8752)
14 Handwheel	Ø≤310: Al (AISI12); Ø≤410: GJS400 (GGG40)
15 Knob	Black bakelite

DEFLECTION CONE "C"

DIMENSIONS (mm) Handwheel Non Rising Stem

DN	Pressures	A	B	C	D	E	F	ØG	H	Weight (kg.)
50	16 bar	41	119	125	105	144	63	225	373	7
65	16 bar	41	134	125	115	161	63	225	400	8
80	16 bar	51	149	125	124	177	63	225	425	9
100	16 bar	51	169	125	140	202	63	225	466	11
125	16 bar	56	180	125	150	226	63	225	500	15
150	10 bar	60	206	125	175	252	63	225	551	20
200	10 bar	60	262	142	205	317	73	310	656	32
250	10 bar	69	318	142	250	372	73	310	756	46
300	6 bar	78	372	142	300	422	73	310	856	62
350	6 bar	78	431	197	338	516	98	410	1013	96
400	6 bar	89	486	197	392	572	98	410	1123	124
450	5 bar ⁽¹⁾	89	540	201	432	635	98	550	1226	168
500	4 bar ⁽¹⁾	114	602	201	485	698	98	550	1342	192
600	4 bar ⁽¹⁾	114	708	201	590	797	98	550	1546	245
700	2 bar	118	834	380	686	890	150	800	1723	405
750	2 bar	118	884	380	760	945	150	800	1855	455
800	2 bar	118	1015	320	795	989	150	800	1934	512
900	2 bar	118	1040	320	900	1118	150	800	2168	630
1000	2 bar	118	1150	320	980	1220	150	800	2350	732

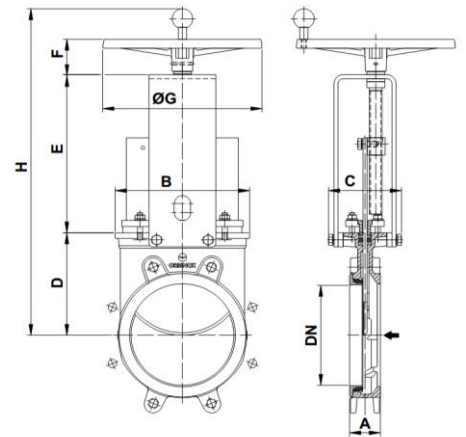

DIMENSIONS (mm) Pneumatic Actuator (D/A)

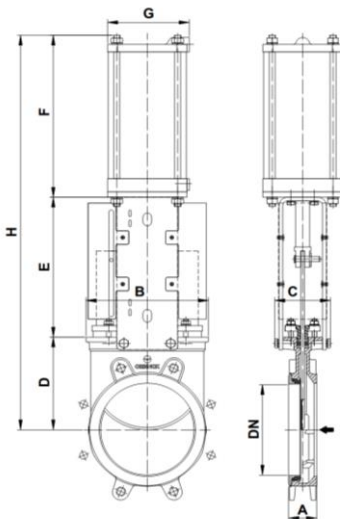

DN	Pressures	A	B	C	D	E	F	G	H	Weight (kg.)	Standard Cyl.	Connect.
50	16 bar	41	119	125	105	129	178	115	412	9	C100/62	1/4" G
65	16 bar	41	134	125	115	146	193	115	454	10	C100/77	1/4" G
80	16 bar	51	149	125	124	162	211	115	497	11	C100/95	1/4" G
100	16 bar	51	169	125	140	187	231	115	558	14	C100/115	1/4" G
125	16 bar	56	180	125	150	211	271	140	632	20	C125/143	1/4" G
150	10 bar	60	206	125	175	237	296	140	708	27	C125/168	1/4" G
200	10 bar	60	262	142	205	309	358	175	872	46	C160/220	1/4" G
250	10 bar	69	318	142	250	364	428	220	1042	69	C200/270	3/8" G
300	6 bar	78	372	142	300	414	478	220	1192	86	C200/320	3/8" G
350	6 bar	78	431	197	338	500	541	220	1379	135	C200/375	3/8" G
400	6 bar	89	486	197	392	577	599	277	1568	165	C250/425	3/8" G
450	5 bar ⁽¹⁾	89	540	270	432	643	641	277	1715	220	C250/475	3/8" G
500	4 bar ⁽¹⁾	114	602	270	485	706	691	277	1882	280	C250/525	3/8" G
600	4 bar ⁽¹⁾	114	708	270	590	805	791	277	2196	330	C250/625	3/8" G
700	2 bar	118	834	380	686	875	985	277	2571	520	C250/730	3/8" G
750	2 bar	118	884	380	760	930	1035	382	2740	585	C300/780	1/2" G
800	2 bar	118	1015	320	791	974	1085	382	2844	650	C300/830	1/2" G
900	2 bar	118	1040	320	895	1105	1202	382	3220	850	C300/930	1/2" G
1000	2 bar	118	1146	320	975	1217	1296	382	3496	1060	C300/1030	1/2" G

Actuator designed with 6 bar air supply and for standard catalogue differential pressure

DIMENSIONS (mm) Electric Actuator Non Rising Stem

DN	Pressures	A	B	C	D	E	F	ØG	H	I	J	L	M	Stem Ø x pitch	Torque (N·m)
50	16 bar	41	119	125	105	129	377	160	552	265	249	72	238	20 x 3	10
65	16 bar	41	134	125	115	146	404	160	579	265	249	72	238	20 x 3	10
80	16 bar	51	149	125	124	162	429	160	604	265	249	72	238	20 x 3	10
100	16 bar	51	169	125	140	187	470	160	645	265	249	72	238	20 x 3	10
125	16 bar	56	180	125	150	211	504	160	679	265	249	72	238	20 x 3	15
150	10 bar	60	206	125	175	237	560	160	730	265	249	72	238	20 x 3	20
200	10 bar	60	262	142	205	309	669	160	814	265	249	82	238	25 x 4	30
250	10 bar	69	318	142	250	364	799	160	944	265	249	82	238	25 x 4	45
300	6 bar	78	372	142	300	414	904	160	1044	265	249	82	238	25 x 4	40
350	6 bar	78	431	197	338	472	940	200	1115	283	254	128	248	35 x 6	70
400	6 bar	89	486	197	392	552	1044	200	1219	283	254	128	248	35 x 6	90
450	5 bar ⁽¹⁾	89	540	270	432	610	1172	200	1347	283	254	130	248	35 x 6	110
500	4 bar ⁽¹⁾	114	602	270	485	670	1280	200	1455	283	254	130	248	35 x 6	95
600	4 bar ⁽¹⁾	114	708	270	590	800	1565	315	1750	389	336	130	286	35 x 6	140
700	2 bar	118	834	380	686	900	1763	315	1948	389	336	202	285	40 x 7	120
750	2 bar	118	884	380	760	945	1882	315	2067	389	336	202	286	40 x 7	140
800	2 bar	118	1015	320	791	980	1948	315	2133	389	336	202	286	50 x 8	180
900	2 bar	118	1040	320	895	1087	2157	400	2342	389	339	202	286	50 x 8	220
1000	2 bar	118	1150	320	975	1200	2350	400	2535	389	339	202	286	50 x 8	300
1200	2 bar	150	1400	450	1037	1485	2732	500	2917	430	365	284	303	60 x 9	480

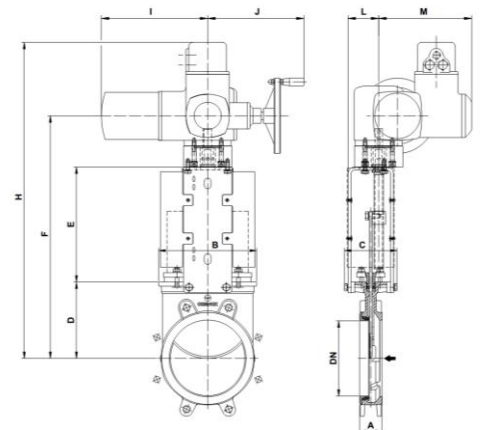

⁽¹⁾ 6 bar with duplex gate