

Peripheral pumps with brass pump body

 Clean water

 Industrial use



PERFORMANCE RANGE

- Flow rate up to **45 l/min** (2.7 m³/h)
- Head up to **90 m**

APPLICATION LIMITS

- Manometric suction lift up to **8 m**
- Liquid temperature between **-10 °C** and **+90 °C**
- Ambient temperature between **-10 °C** and **+40 °C** (+50 °C for PQ 60-Bs)
- Max. working pressure **10 bar**
- Continuous service **S1**

CONSTRUCTION AND SAFETY STANDARDS

EN 60335-1
IEC 60335-1
CEI 61-150

EN 60034-1
IEC 60034-1
CEI 2-3



CERTIFICATIONS

Company with management system certified DNV
ISO 9001: QUALITY



INSTALLATION AND USE

Suitable for use with clean water that does not contain abrasive particles and with liquids that are not chemically aggressive towards the materials from which the pump is made. The hydraulic characteristics of these pumps, coupled with their compactness, makes them suitable for use in industrial applications. Installation needs to be undertaken in well ventilated closed areas or anyway protected from bad weather.

PATENTS - TRADE MARKS - MODELS

- Motor bracket: patent n. IT1243605
- Shaft: patent n. 0000275945 (PQ60-Bs, PQ65-Bs)
- Registered EU Design n. 002146548

OPTIONS AVAILABLE ON REQUEST

- Special mechanical seal
- EN 10088-3 - 1.4401 (AISI 316) stainless steel pump shaft
- Other voltages or 60 Hz frequency

CHARACTERISTIC CURVES AND PERFORMANCE DATA

50 Hz n= 2900 min⁻¹ HS= 0 m

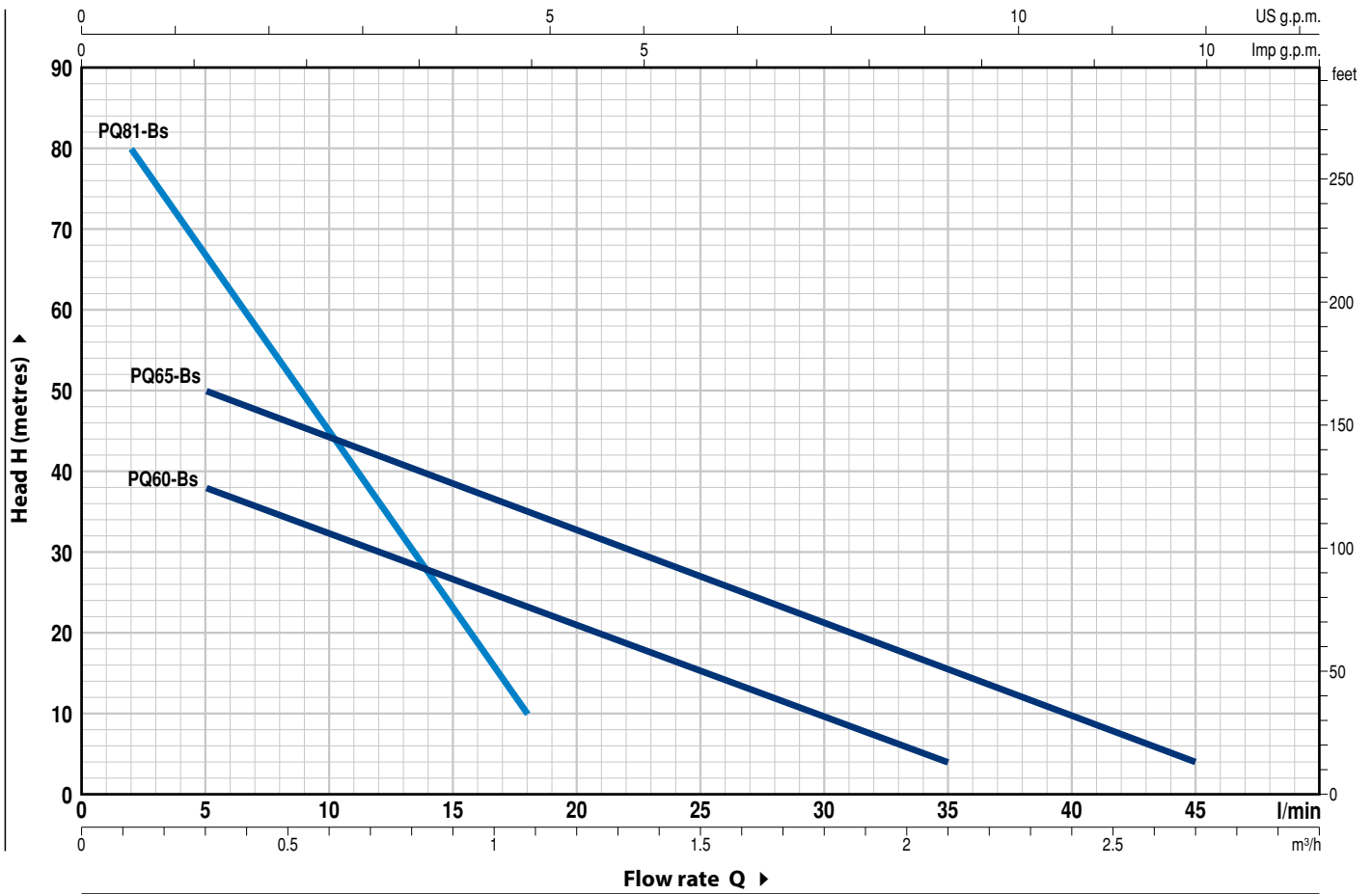

MODEL		POWER (P ₂)			Q	Flow rate									
Single-phase	Three-phase	kW	HP	▲		0	0.3	0.6	0.9	1.2	1.5	1.8	2.1	2.4	2.7
						0	5	10	15	20	25	30	35	40	45
PQm 60-Bs	PQ 60-Bs	0.37	0.50	IE3	H metres	44	38	32	27	21	15	10	4		
PQm 65-Bs	PQ 65-Bs	0.55	0.75			55	50	44	38	33	27	21	15	10	4

MODEL		POWER (P ₂)			Q	Flow rate									
Single-phase	Three-phase	kW	HP	▲		0	0.12	0.24	0.36	0.48	0.60	0.72	0.84	0.96	1.08
						0	2	4	6	8	10	12	14	16	18
PQm 81-Bs	PQ 81-Bs	0.50	0.70	IE3	H metres	90	80	71	63	54	45	37	28	19	10

Q = Flow rate H = Total manometric head HS = Suction height

Tolerance of characteristic curves in compliance with EN ISO 9906 Grade 3B.

▲ Three-phase motor efficiency class (IEC 60034-30-1)

POS. COMPONENT CONSTRUCTION CHARACTERISTICS

1	PUMP BODY	Brass complete with threaded ports in compliance with ISO 228/1				
2	MOTOR BRACKET	Aluminium with brass insert (patented), reduces the risk of impeller seizure				
3	IMPELLER	Brass with peripheral radial vanes				
4	MOTOR SHAFT	Stainless steel AISI 431				
5	MECHANICAL SEAL	Seal	Shaft	Materials		
		Model	Diameter	Stationary ring	Rotational ring	Elastomer
		ST1-12	Ø 12 mm	Silicon carbide	Graphite	NBR
6	BEARINGS	6201 ZZ / 6201 ZZ				
7	CAPACITOR	Pump	Capacitance			
		<i>Single-phase</i>	<i>(230 V or 240 V)</i>	<i>(110 V)</i>		
		PQm 60-Bs	10 µF - 450 VL	25 µF - 250 VL		
		PQm 65-Bs	14 µF - 450 VL	25 µF - 250 VL		
		PQm 81-Bs	14 µF - 450 VL	25 µF - 250 VL		
8	ELECTRIC MOTOR	PQm-Bs: single-phase 230 V - 50 Hz with thermal overload protector incorporated into the winding. PQ-Bs: three-phase 230/400 V - 50 Hz. ⇒ The pump is fitted with a high performance motor in class IE3 (IEC 60034-30-1) – Insulation: class F – Protection: IP X4				

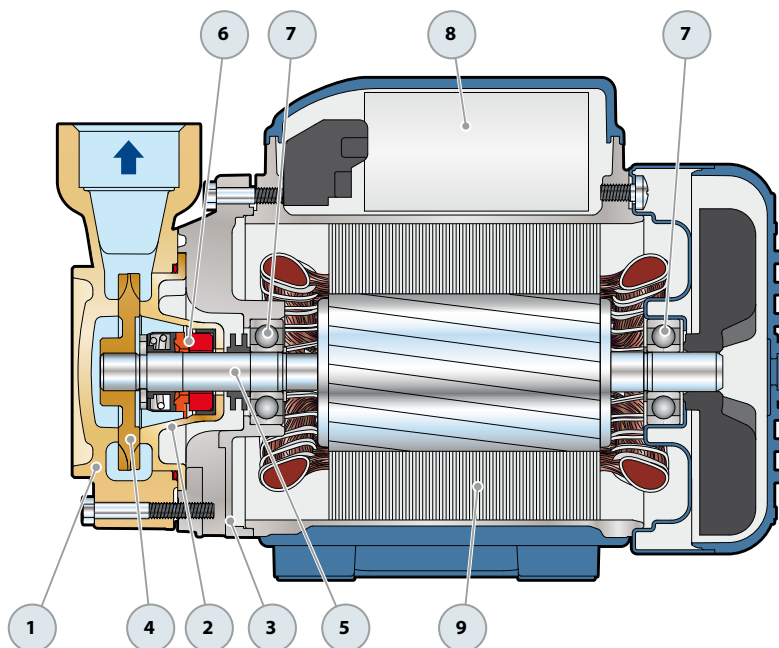

DIMENSIONS AND WEIGHT

PQ 60-Bs

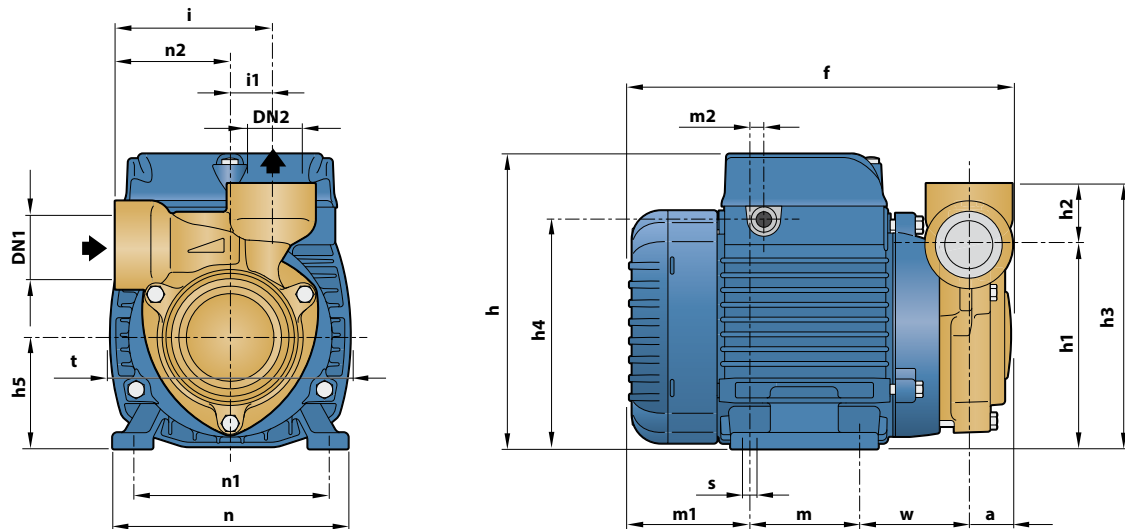

PQ 65-Bs, PQ 81-Bs

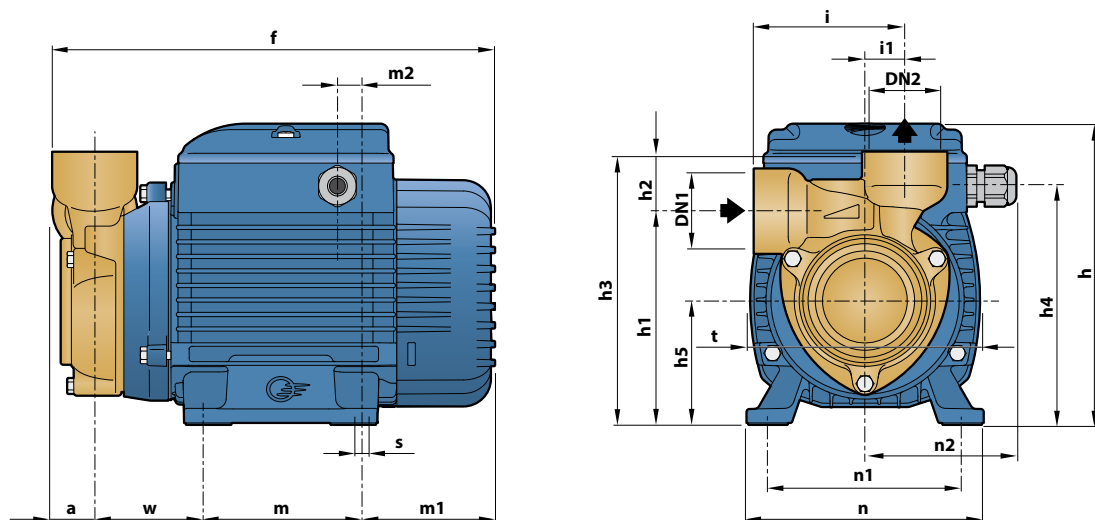

MODEL		PORTS		DIMENSIONS mm																	kg						
Single-phase	Three-phase	DN1	DN2	a	f	h	h1	h2	h3	h4	h5	i	i1	m	m1	m2	n	n1	n2	t	w	s	1~	3~			
PQm 60-Bs	PQ 60-Bs	1"	1"	22	192	145	101	30	131	112	56			55	62	8	116	94	100	55.5	118			5.0	5.0		
PQm 65-Bs	PQ 65-Bs			23	225		108		143				76	20									53	7	7.0	6.9	
PQm 81-Bs	PQ 81-Bs	½"	½"	19	224		155		119	22	141			120.5	63		80	70	11.5	119	100	76.5	117		56	6.8	6.1

ABSORPTION

MODEL	VOLTAGE	
Single-phase	230 V	110 V
PQm 60-Bs	2.6 A	5.2 A
PQm 65-Bs	3.7 A	7.4 A
PQm 81-Bs	3.4 A	6.8 A

MODEL	VOLTAGE	
Three-phase	230 V	400 V
PQ 60-Bs	2.0 A	1.15 A
PQ 65-Bs	3.0 A	1.7 A
PQ 81-Bs	2.2 A	1.3 A