

Rannie 24 / Gaulin 24

Introduction

The Rannie 24 / Gaulin 24 homogeniser, a positive displacement triplex, reciprocating plunger pump, is fitted with an application-specific homogenising valve assembly: single-stage with manual actuation.

The Rannie 24 / Gaulin 24 homogeniser incorporates a durable slow-speed power end that reduces vibration and noise. Easy access to the lubrication oil and other auxiliary systems simplifies maintenance saving time and money. Liquid end options include a three-piece valve housing (Rannie) and a mono-block design (Gaulin) (ball and poppet style).

Design features of both the Rannie and Gaulin simplify routine maintenance. Materials for plungers, packings, pump valves, valve seats and seals are custom-selected for your application. APV engineers will work with you to optimise the configuration for your specific application.



STANDARD OPTIONS

- Two-stage manual
- Single-stage hydraulic valve actuation (HVA)
- Two-stage hydraulic valve actuation (HVA)
- Single-stage automatic hydraulic system (AHS)
- Two-stage automatic hydraulic system (AHS)
- Pulsation dampener(s) on inlet and outlet
- Aseptic cylinder design
- Electronic pressure transmitter excl. display
- High-pressure outlet
- Inlet pressure gauge
- Plunger lubrication control package
- Tungsten carbide homogenising valve
- Square plunger seals and ceramic plungers (Rannie valve housing only)
- External cooling fan/main motor
- Motor starter
- Control cabinet, stainless steel
- Thermostat/oil temperature

SPECIAL OPTIONS

- Acid-proof cylinder (Gaulin valve housing only)
- Ceramic plungers with U- or V-rings
- Explosion-proof design
- Electropolished wettables
- High-temperature design
- Flow switch - power end cooling
- UFO - Unit for Filtration of Oil



RANNIE THREE-PIECE
VALVE HOUSING



GAULIN MONO-BLOCK
DESIGN

RANNIE/THREE-PIECE VALVE HOUSING POPPET AND BALL TYPE VALVES

TYPE	US MAX. CAP./MAX. PRESS.		METRIC MAX. CAP./MAX. PRESS.	
	GPH	PSI	LPH	BAR
50.66	1370	2175	5200	150
42.66	980	2900	3700	200
38.66	750	3625	2850	250
35.66	660	4300	2500	300
30.66	490	5800	1850	400
22.66	250	8700	950	600
20.66	170	11600	650	800
18.66	130	14500	500	1000

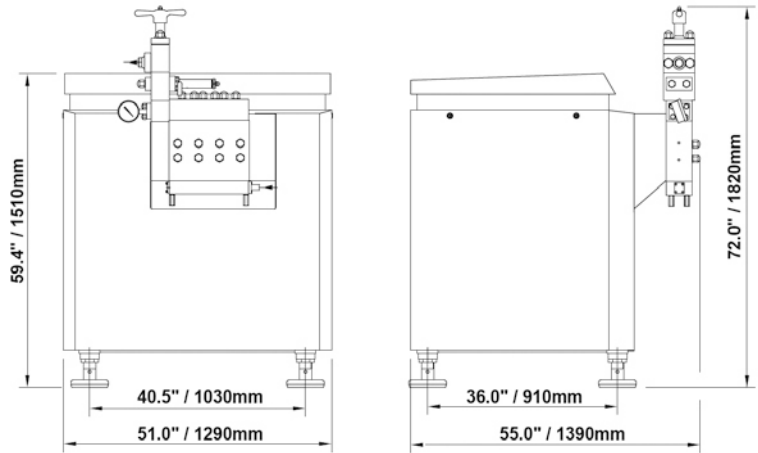

GAULIN/MONO-BLOCK DESIGN

TYPE	US MAX. CAP./MAX. PRESS.		METRIC MAX. CAP./MAX. PRESS.	
	GPH	PSI	LPH	BAR
POPPET TYPE VALVES				
1.0	2690	1015	10200	70
2.5	1110	2500	4200	170
3.0	950	3000	3600	210
4.3	660	4300	2500	300
5.8	490	5800	1850	400
BALL TYPE VALVES				
2.5	820	2500	3100	170
3.0	725	3000	2750	210
4.3	500	4300	1900	300
5.8	370	5800	1400	400
8.7	185	8700	700	600

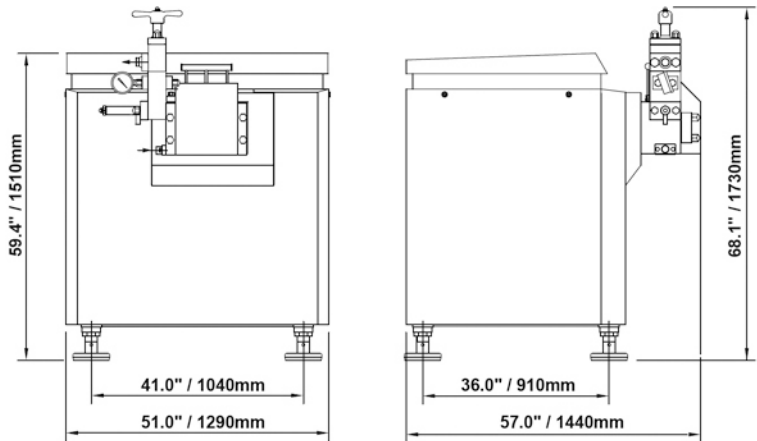

DIMENSIONS (SINGLE STAGE)

DIMENSIONS PACKED IN A CRATE LXWXH (IN.)	DIMENSIONS PACKED IN A CRATE LXWXH (CM)	CUBIC MEASURE M ³	GROSS WEIGHT IN A CRATE INCL. MOTOR
67X61X82	170X155X207	5.4	3,968 LB./1,800 KG

