

Operating instructions

FMP Series

Peristaltic Pump



Table of contents

1. Introduction	3
2. Safety and Responsibility	5
3. Functional description.....	9
4. Transport and Storage	11
5. Assembly and Installation	12
6. Commissioning.....	18
7. Maintenance, repair, malfunctions, disposal and spare parts	19
8. Spare parts	25
9. Declaration of Conformity.....	43
10. Guarantee.....	44

1. Introduction

This manual forms an integral part of the pump and must accompany it until its demolition. The series FMP peristaltic pump is a machine destined to work in industrial areas and as such the instruction manual must form part of the legislative dispositions and the applicable technical standards and does not substitute any installation standard or eventual additional standard.

1.1 Explanation of the safety information



The instructions of this manual, whose inobservance is determined as a failure to meet safety standards, are identified by this symbol



The instructions of this manual, whose inobservance compromises electrical safety



The instructions of this manual, whose inobservance compromises the correct working of the pump, are identified with this symbol.

1.2 Users' qualifications

Pumps are machines that due to their functioning under pressure and moving parts can present dangers.

- Improper use
- Removing the protections and/or disconnecting the protection device

- The lack of inspections and maintenance

They can cause serious damage or injury.

The person in charge of safety should therefore guarantee that the pump is transported, installed, put in service, used, maintained and repaired by qualified personnel who should therefore possess:

- Specific training and sufficient experience.
- Knowledge of the technical standards and applicable laws.
- Knowledge of the general national and local safety standards and also of installation.

Any work carried out on the electrical part of the pump should be authorized by the person responsible for safety. Given that the pump is destined to form part of an installation, it is the responsibility of whoever supervises the installation to guarantee absolute safety, adopting the necessary measures of additional protection.

2. Safety and Responsibility

2.1 General safety information



Live parts

Possible consequence: Fatal or very serious injuries.

- Measure: The device must be disconnected from the power supply before it is opened
- Isolate damaged faulty or manipulated devices from the mains in order to de-energise.



Emergency stop switch

Possible consequence: Fatal or very serious injuries.

An emergency stop switch is to be connected for the entire plant. This should enable the entire plant to be shut down in the event of an emergency in such a way that the overall plant can be brought into a safe condition.



Unauthorized access

Possible consequence: Fatal or very serious injuries.

- Measure: Ensure that there can be no unauthorized access to the unit.



Hazardous media/contamination of persons and equipment

Possible consequence: Fatal or very serious injuries material damage.

- Ensure that the pump hoses are resistant against the media being conveyed
- Always observe the safety data sheets for the media to be conveyed. The system operator must ensure that these safety data sheets are available and that they are kept up-to-date.
- The safety data sheets for the media being conveyed are always decisive for initiating countermeasures in the event of leakage to the media being conveyed.

- Observe the general restrictions in relation to viscosity limits, chemical resistance and density.
- Always switch the pump off before exchanging the pump hose

**CAUTION****Correct and proper use**

Possible consequence: Fatal or very serious injuries.

- The unit is not intended to convey or regulate gases or solid media
- Do not exceed the rated pressure, speed or temperature for the pump
- The unit may only be used in accordance with the technical data and specifications provided in these operating instructions and in the operating instructions for the individual components
- The system is not designed for use in areas of risk from explosion
- Only switch the pump on if it has been properly fastened to the floor
- Only switch the pump on if the front cover has been attached.
- Do not carry out any maintenance operations or dismantle the pump without first making sure that the pipes are not under pressure and are empty or isolated.
- In the case of the hose becoming stuck during extraction or fitting it is necessary to reverse the direction of the pump, relubricate, and then repeat the operation.
- As the peristaltic pump is volumetric and its functioning is positive displacement, it is necessary to prevent a possible overload of pressure, due to for example, the accidental closure of a valve. For this reason it is advisable to fit a safety device such as: a safety valve, pressure limiter, etc.

**CAUTION****Operational lifetime of the pump hoses**

Possible consequence: Fatal or very serious injuries.

The operational lifetime of the pump hoses cannot be precisely specified. For this reason, the possibility of fracture and consequential leakage of liquids must be accounted for. If the hose rupture alarm (optional) is fitted, then the pump can be stopped and / or an electrical valve can be actuated.

In addition, as the hose has an indeterminate life and due to the possibility of its breakage or deterioration, the user is responsible for the prevention of a possible (although most unlikely) incorporation of particles from the hose into the product being pumped. This can be achieved e.g. by means of filtration, a hose rupture alarm or other means suitable for the respective process



CIP cleaning

In the event of CIP cleaning, it is necessary to obtain information from the manufacturer about correct installation of the pump (a special installation is required) as well as regarding the compatibility of the cleaning agents with the pump hoses and the hydraulic connections.

Cleaning should be undertaken at the recommended maximum temperature.



Direction of rotation/flow direction

Possible consequence: Material damage right through to destruction of the unit.

- The pump's direction of rotation in relation to the desired flow direction must be checked prior to every start.



Disconnect the pump from the mains

Possible consequence: Personal injury.

You may only carry out work on the pump after it has previously been switched off and disconnected from the mains.



Environmental influences

Possible consequence: Material damage right through to destruction of the unit.

- The device is not suitable for outdoor operation
- Take suitable measures to protect the device from environmental influences such as:
 - UV rays
 - Moisture
 - Frost, etc.

3. Functional description

The FMP Series is a displacement pump. The feed chemical is conveyed by the rotor squeezing the hose in the direction of flow. No valves are needed for this. This ensures gentle handling of the metered media.

The FMP Series has been designed for safe and uncomplicated operation, as well as straightforward maintenance.

The FMP Series can be used for many different media. However, this pump type is often the optimal solution for abrasive, shear-sensitive and viscose media.

Typical areas of use include processes where only a low discharge pressure is required (max. 8 Bar).

3.1 Construction

Main modules:

- Drive Unit
- Housing
- Base frame

The pump housing is closed off with a screwed front cover in order to avoid the risk of injury.

The motor serves to drive the rotor. Two rollers at the ends of the rotor serve to press the pump hose against the pump housing.

The rotary movement of the rotors alternately press and relax the rollers in relation to the pump hose. This serves to suck the media and convey it into the metering line.

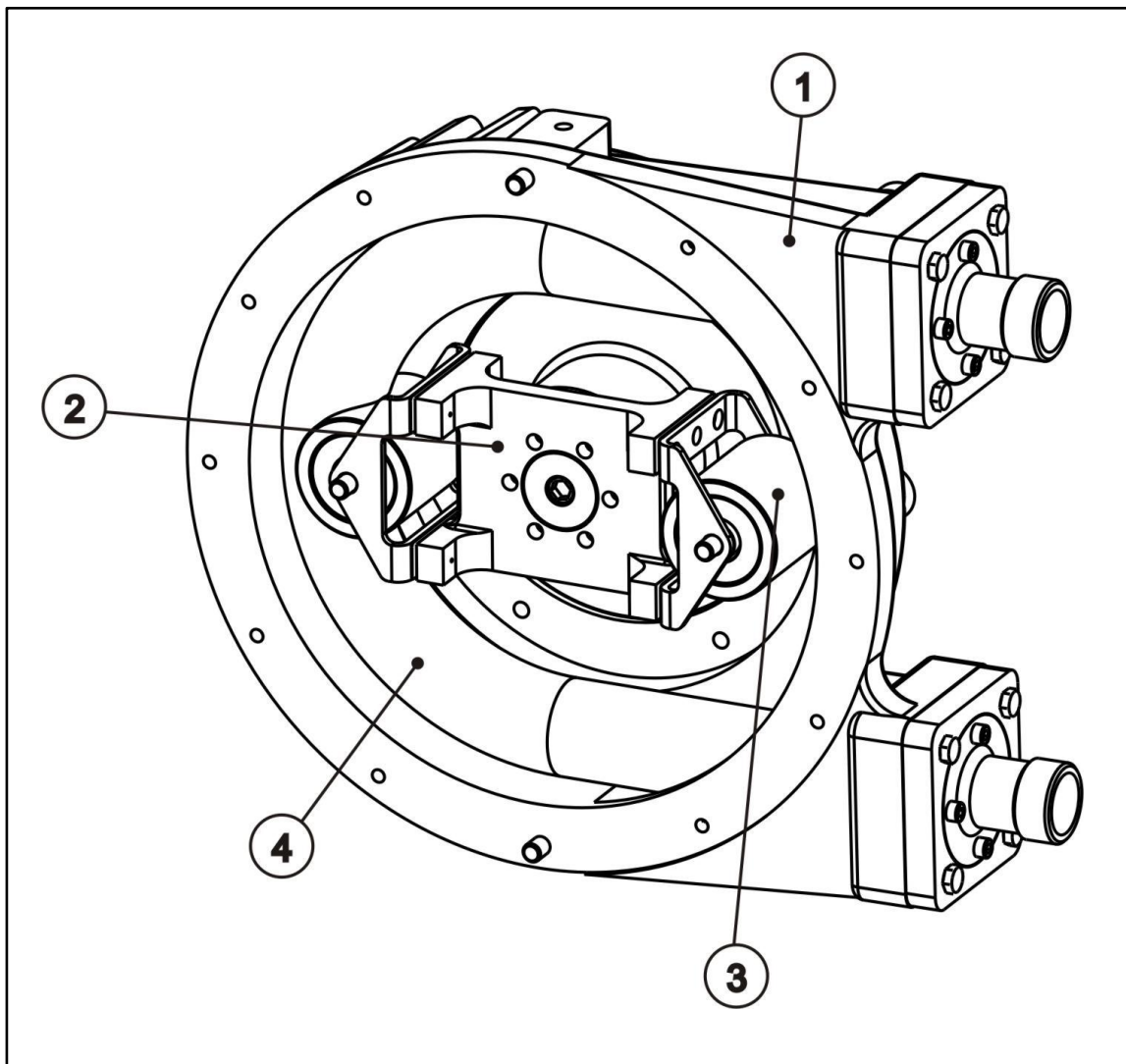

Fig. 1: Diagram of functional principle

1 Housing

3 Rollers

2 Rotor

4 Hose

4. Transport and Storage

4.1 Transport

- The pump is protected by a cardboard packaging.
- The packaging materials are recyclable.

4.2 Storage

- The pump should be in a resting position. (The hose should not be compressed).
- Avoid areas open to harsh weather or excessive humidity.
- For storage periods of longer than 60 days, protect the coupling surfaces (clamps, reducers, motors) with adequate anti-oxidant products.
- Spare hoses should be stored in a dry place away from direct light.

4.3 Elevation

Models FMP-30, FMP-40, FMP-50

- To elevate the pump use the eye bolt.

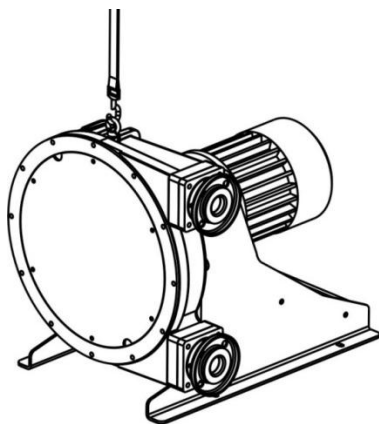

Models FMP-60, FMP-70, FMP-70D

- To elevate the pump, it's necessary to use elevation belts.

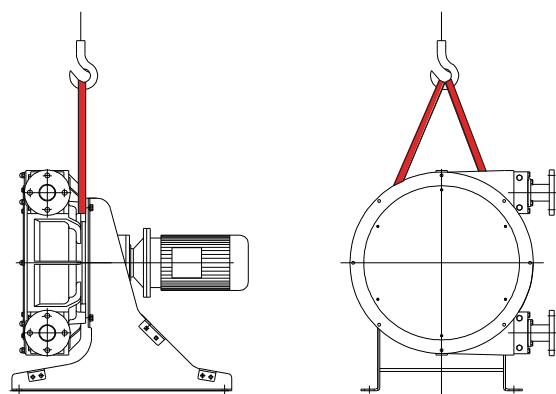

5. Assembly and Installation

5.1 Ambient conditions

Assembly is to be carried out in the following order. If the pump has to be installed outdoors, then it is to be equipped with protection against sunlight and weather influences. When positioning the pump, ensure that sufficient room for access is provided for all types of maintenance work.

Limit values for hose temperature and pressure

Material Hose	Min. Temp. (°C) Feed chemical	Max. Temp (°C) Feed chemical	Min. Temp (°C) Environment	Max. Pressure (Bar)
NR	- 20	80*	- 40	8
NBR	- 10	80*	- 40	8
EPDM	- 10	80*	- 40	8
NR-A	- 10	80*	- 40	8
NBR-A	- 10	80*	- 40	8
NORPRENE ¹	- 10	120*	- 40	2

¹ Only available for FMP-40

* At max. T^a , the life of hose is drastically reduced. Please contact with Boyser or authorized distributor for high T^a application.

5.2 Correct installation of the pump

5.2.1 Suction side

The pump is to be positioned as near as possible to the liquid container, so that the suction side is kept as short and straight as possible. The suction line must be absolutely airtight and made of a suitable material, so that it is not squeezed together under vacuum. The diameter must correspond to the rated diameter of the pump hose. A larger diameter is recommended in the event of viscous liquids. The pump is self-priming and does not require an admission valve. The pump is reversible and the suction connection can therefore comprise of one of

two options. Normally the option is selected which is best suited to the physical conditions of the installation. It is recommended to use a flexible transition between two fixed pipes and the hydraulic connection of the pump, in order to avoid the transmission of vibrations.

5.2.2 Discharge side

The discharge line is to be kept as straight and short as possible, in order to avoid performance reduction. The diameter must correspond to the rated diameter of the pump hose. A larger diameter is recommended in the event of viscous liquids. It is recommended to use a flexible transition between two fixed pipes and the hydraulic connection of the pump, in order to avoid the transmission of vibrations.

5.3 Adjusting the roller pressure

The peristaltic pump is equipped with shims, in order to adjust the precise pressure distance to the roller (dependent on speed and operating pressure).

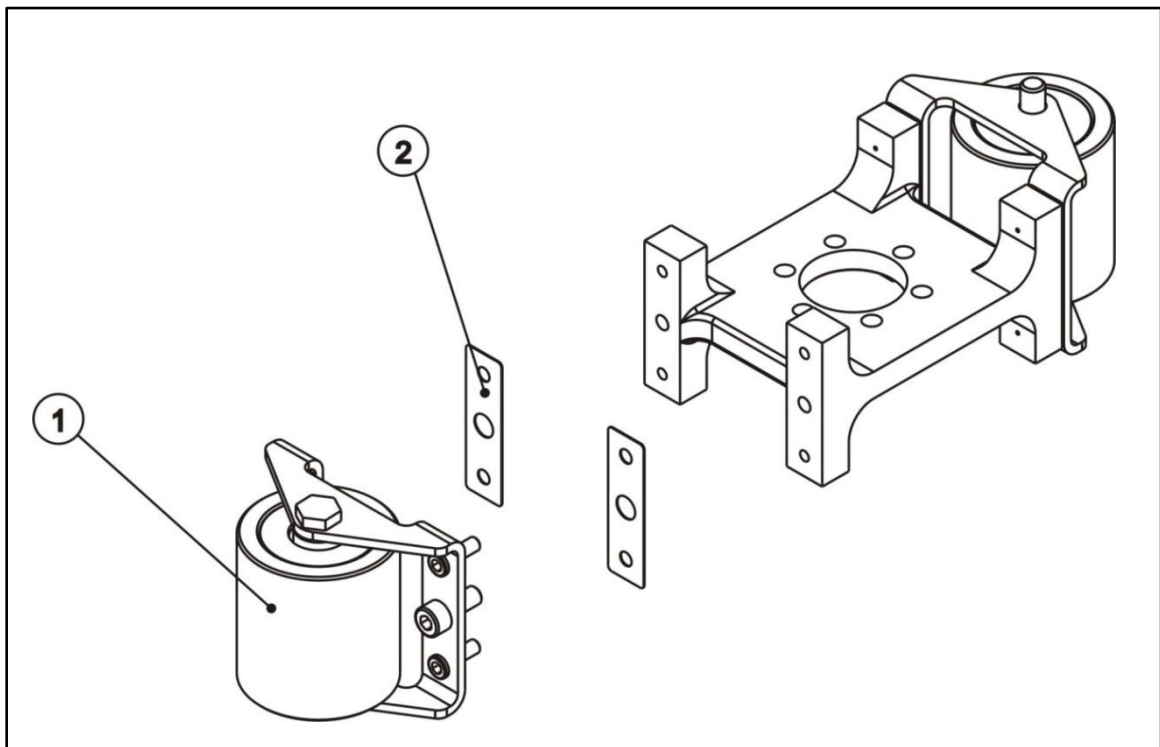

Fig 2: 1- Roller / 2- Shims

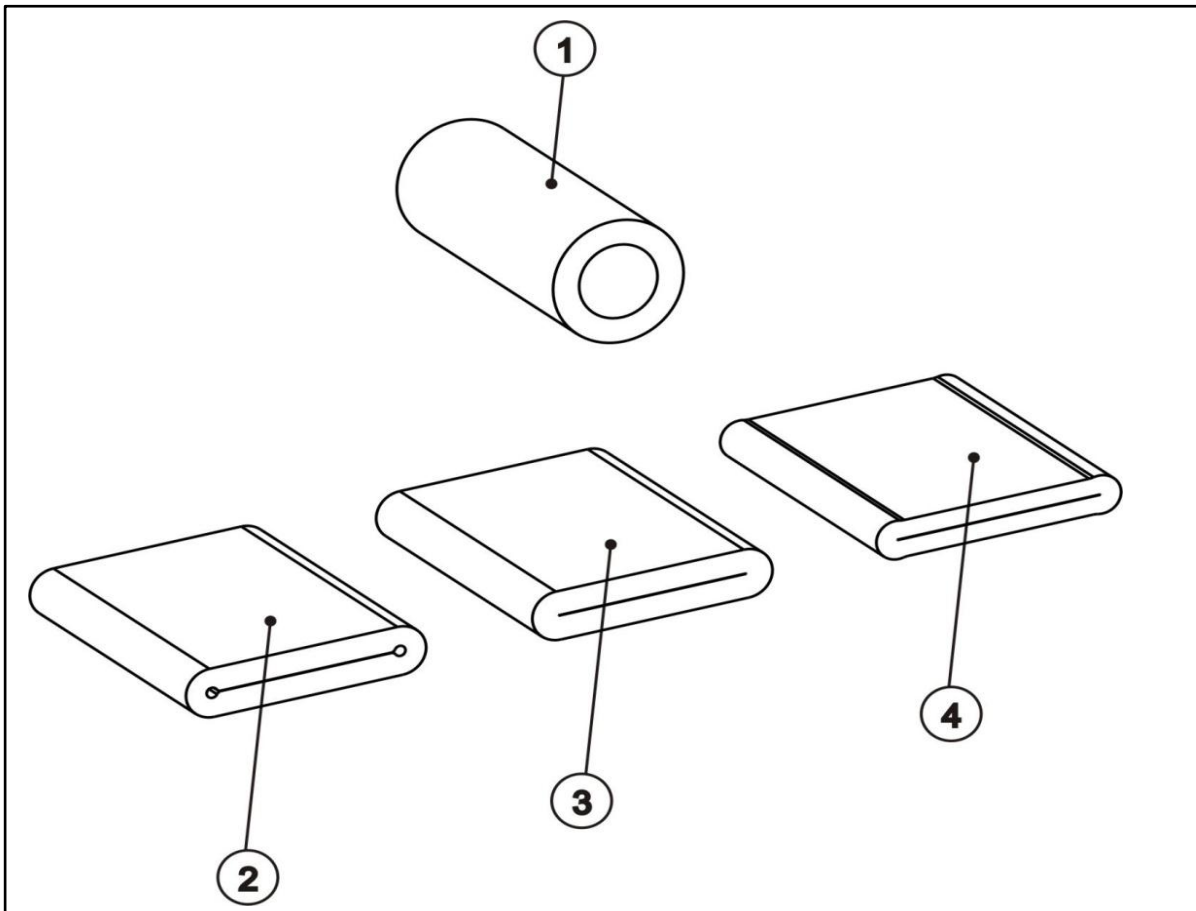

Fig. 3: Squeezing the hose

- 1. Hose in normal shape*
- 2. Insufficient squeezing (back flowing media in the cavity will destroy the hose within a short period of time)*
- 3. Perfect squeezing*
- 4. Excessive squeezing (increased wear and tear to pump and hose)*

The shims are fitted in the factory. You can adapt the number of shims to the actual operating conditions according to the following table.

5.3.1 FMP-30 Model (Number of shims of 0,5 mm thickness):

a) NR, NBR, EPDM, HYPALON, NR-A and NBR-A:

		1/min				
		0-19	20-39	40-59	60-79	80-99
Bar	0,5	2	2	1	1	1
	2,0	2	2	2	2	2
	4,0*	3	2	2	2	2
	6,0	3	3	3	2	--
	8,0	4	3	3	--	--
*Factoring default setting if working pressure is not informed						

5.3.2 FMP-40 Model (Number of shims of 1 mm thickness):

a) NR, NBR, EPDM, HYPALON, NR-A and NBR-A:

		1/min				
		0-19	20-39	40-59	60-79	80-99
Bar	0,5	4	4	4	4	3
	2,0	5	4	4	4	4
	4,0*	5	5	5	4	4
	6,0	6	5	5	--	--
	8,0	6	6	--	--	--
*Factoring default setting if working pressure is not informed						

b) Norprene:

		1/min				
		0-19	20-39	40-59	60-79	80-99
Bar	0,5	14	14	14	14	14
	2,0*	14	14	14	14	14
*Factoring default setting if working pressure is not informed						

5.3.3 FMP-50 Model (Number of shims of 1 mm thickness):

a) NR, NBR, EPDM, HYPALON, NR-A and NBR-A:

		1/min				
		0-19	20-39	40-59	60-79	80-99
Bar	0,5	1	1	1	0	0
	2,0	2	1	1	1	1
	4,0*	2	2	2	2	2
	6,0	3	3	3	3	--
	8,0	4	3	--	--	--
*Factoring default setting if working pressure is not informed						

5.3.4 FMP-60 Model (Number of shims of 1 mm thickness):

a) NR, NBR, EPDM, HYPALON, NR-A and NBR-A:

		1/min				
		0-19	20-39	40-59	60-79	80-99
Bar	0,5	6	5	5	5	5
	2,0	6	6	6	6	5
	4,0*	6	6	6	6	6
	6,0	7	6	6	6	6
	8,0	7	7	7	7	--
*Factoring default setting if working pressure is not informed						

5.3.5 FMP-70 Model (Number of shims of 1 mm thickness):

a) NR, NBR, EPDM, HYPALON, NR-A and NBR-A:

		1/min				
		0-19	20-39	40-59	60-79	80-99
Bar	0,5	1	1	0	0	0
	2,0	1	1	1	0	0
	4,0*	2	2	2	1	1
	6,0	3	3	2	--	--
	8,0	4	3	3	--	--
*Factoring default setting if working pressure is not informed						

5.3.6 FMP-70D Model (Number of shims of 1 mm thickness):

Each of the two pump bodies is fitted with the following configuration:

a) NR, NBR, EPDM, HYPALON, NR-A and NBR-A:

		1/min				
		0-19	20-39	40-59	60-79	80-99
Bar	0,5	1	1	0	0	0
	2,0	1	1	1	0	0
	3,0*	2	2	2	1	1
*Factoring default setting if working pressure is not informed						

6. Commissioning

6.1 Testing prior to commissioning the pump

The following tests are to be carried out:

- Ensure that the pump has not been damaged during transportation or storage. Immediately report any damage to the supplier.
- Check that the mains voltage is suitable for the motor.
- Ensure that the hose is suitable for the fluid to be conveyed and that it is not damaged.
- Make sure that the temperature of the liquid does not exceed the recommended temperature range.
- Only switch the pump on if the front cover has been properly attached.
- Check that the rollers are correctly fitted and fastened.
- Check that the drive pump and the inner of the rollers are correctly greased. The specially formulated grease can be obtained from BOMBAS BOYSER, S.L. or from the authorized distributor.
- Check that the thermal overload protection (not included in the delivery scope) corresponds to the value specified on the motor type plate.
- Check whether the direction of rotation is correctly adjusted.
- Check that the optional electrical components are connected and are working properly.
- Install a manometer in the pressure line if the back-pressure value is unknown.
- Check the operating instructions in order to ensure that the flow values, pressures and power consumption of the motor do not exceed the rated values.
- Install a pressure relief valve in the pressure line in order to protect the pump in the event that a valve is unintentionally closed off or the line is blocked in another way.

7. Maintenance, repair, malfunctions, disposal and spare parts

7.1 Lubrication:

- Check that the rollers and the hose are sufficiently lubricated
 - o Check every 300 operating hours
- Gear reducers
 - o *FMP-30, FMP-40 and FMP-50*: The lubrication is permanent. Is not necessary any servicing.
 - o *FMP-60, FMP-70 and FMP-70D*: Exchange the oil at regular intervals in accordance with the gear reducer maintenance manual.

7.2 Exchanging the pump hoses

7.2.1 Exchanging the pump hoses – dismantling

7.2.1.1 Models FMP-30, FMP-40, FMP-50, FMP-70 and FMP-70D

1. Close off all valves, in order to prevent leakage of the feed chemical
2. Dismantle the pipes from both discharge and suction sides
3. Remove the front cover
4. Remove a roller (the roller that is not touching the pump hose)
5. Mount the front cover
6. Turn the rotor with the help of the motor so that the remaining roller is not pressing against the pump hose
7. Dismount the front cover
8. Remove the press flange and connections from the pump housing
9. Remove the press rings
- 10 Remove the pump hose to be exchanged

7.2.1.2 Model FMP-60:

1. Close off all valves, in order to prevent leakage of the feed chemical
2. Dismantle the pipes from both discharge and suction sides
3. Remove the front cover
4. Remove a roller (the roller that is not touching the pump hose)
5. Mount the front cover
6. Turn the rotor with the help of the motor so that the remaining roller is not pressing against the pump hose
7. Dismount the front cover
8. Remove the connections
9. Remove the press flange from the pump housing
- 10 Remove the pump hose to be exchanged
- 11 Dismantle the inserts from both pump hose ends

7.2.2 Exchanging the pump hoses- installation

7.2.2.1 Models FMP-30, FMP-40, FMP-50, FMP-70 and FMP-70D

1. Clean the interior surfaces of the pump housing
2. Lubricate the internal surfaces of the pump housing at the contact surfaces to the pump hose with original silicon grease
3. Check the rollers. Ensure that the roller surfaces are not damaged
4. Lay the pump hose into the pump housing
5. Lay the press rings. Between the end of the hose and the press ring, it has to be a distance of 3-7 mm.

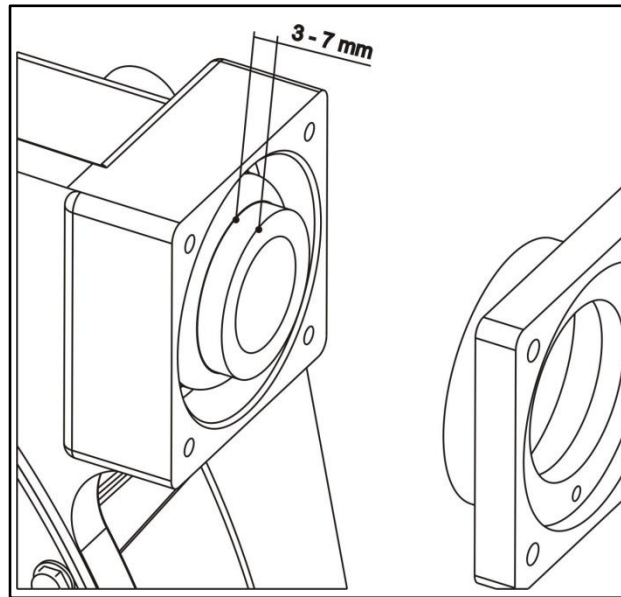

Fig.4: Required distance between the end of the hose and the press ring.

6. Fasten the press flange and the connections to the pump casing, tightening progressive the bolts in clock wise (1, 2, 3, 4, 1, 2, 3, 4, etc...), until the flange becomes totally tighten.

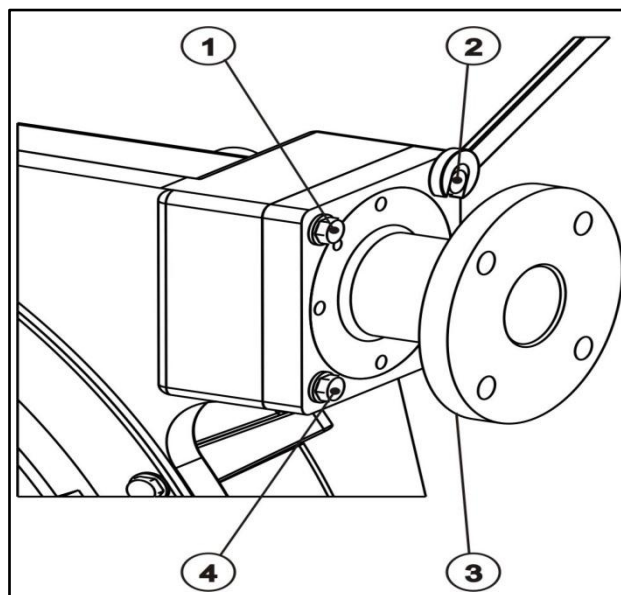

Fig.5: Way to proceed with the screws tightening

7. Mount the front cover
8. Turn the rotor with the help of the motor so that the remaining roller presses against the pump hose
9. Dismount the front cover
10. Re-attach the second roller with shims back onto the rotor
11. Lubricate the pump hose and the rollers
12. Attach the front cover to the pump housing
13. Mount the pipes from both discharge and suction sides
14. Open all of the valves

7.2.2.2 Model FMP-60:

1. Clean the interior surfaces of the pump housing
2. Lubricate the internal surfaces of the pump housing at the contact surfaces to the pump hose with original silicon grease
3. Check the rollers. Ensure that the roller surfaces are not damaged
4. Lay the pump hose into the pump housing
5. Attach the inserts at both hose ends with the help of the press flange
6. Fasten the two parts of press flanges us the base
7. Fasten the press flange to the pump casing
8. Fasten the connections to the press flange
9. Mount the front cover
10. Turn the rotor with the help of the motor so that the remaining roller presses against the pump hose
11. Dismount the front cover
12. Re-attach the second roller with shims back onto the rotor
13. Lubricate the pump hose and the rollers
14. Attach the front cover to the pump housing
15. Mount the pipes from both discharge and suction sides
16. Open all of the valves

7.3 Troubleshooting

Problem	Possible cause	Solution
Increased pump temperature	Pump hose has no lubricant	Lubricate pump hose
	Increased product temperature	Reduce product temperature
	Insufficient or poor suction conditions	Check suction line for blockages
	Pump speed too high	Reduce pump speed
Reduced flow or pressure	Valves on discharge and or suction side completely or partially closed	Open valves
	Pump hose insufficiently compressed	Check number of shims
	Pump hose rupture (the product leaks out into the housing)	Exchange pump hose
	Partial blockage of the suction line	Clean pipe
	Insufficient product quantity in storage container	Fill storage container or exchange pump
	Insufficient diameter on the suction side	Increase the diameter on the suction side, as far as possible
	Suction line too long	Shorten the suction line, as far as possible
	High viscosity of medium	Reduce viscosity, as far as possible
Reduced flow or pressure	Air introduction in the suction connections	Check connections and accessories for air tightness
Reduced flow or pressure	High pulsation on suction	Tighten connections and accessories Mount antipulsation equipment Reconsider application (speed, etc)
Vibrations on pumps and pipelines	The pipes are not correctly fastened	Fasten pipes correctly (e.g. wall brackets)
	Pump speed too high	Reduce pump speed
	Insufficient nominal width of the pipes	Increase nominal width
	Pump base plate loose	Fasten base plate
	Pulsation dampers insufficient or missing	Install pulsation dampers on suction and / or discharge side.

Short operational lifetime of the hoses	Chemical exposure	Check the compatibility of the hose with the liquid being conveyed, the cleaning fluid and the lubricant
	High pump speed	Reduce pump speed
	High conveying temperature	Reduce product temperature
	High operating pressure	Reduce operating pressure
	Pump cavitation	Check the suction conditions
	Abnormal elevation of temperature	Check rollers shaft mounting
	Unsuitable lubricant	Use lubricant BOYSER
	Insufficient quantity of grease	Top up lubricant
Pump hose pulled into the pump housing	High inlet pressure (> 3 bar)	Reduce inlet pressure
	Pump hose filled with deposits	Clean or replace the pump hose
	Holder (press flange) insufficiently tightened	Re-tighten holder (press flange)
	Insufficient grease	Top lubricant
The pump does not start up	Insufficient motor performance	Check motor and replace if necessary
	Insufficient output from frequency converter	The frequency converter must match the motor
	Blockage in the pump	Check voltage. Start occurs at minimum 10 Hz
	Blockage in the pump	Check if the suction or discharge side is blocked. Rectify blockage

8. Spare parts

8.1 Spare parts exploded FMP-30 Model

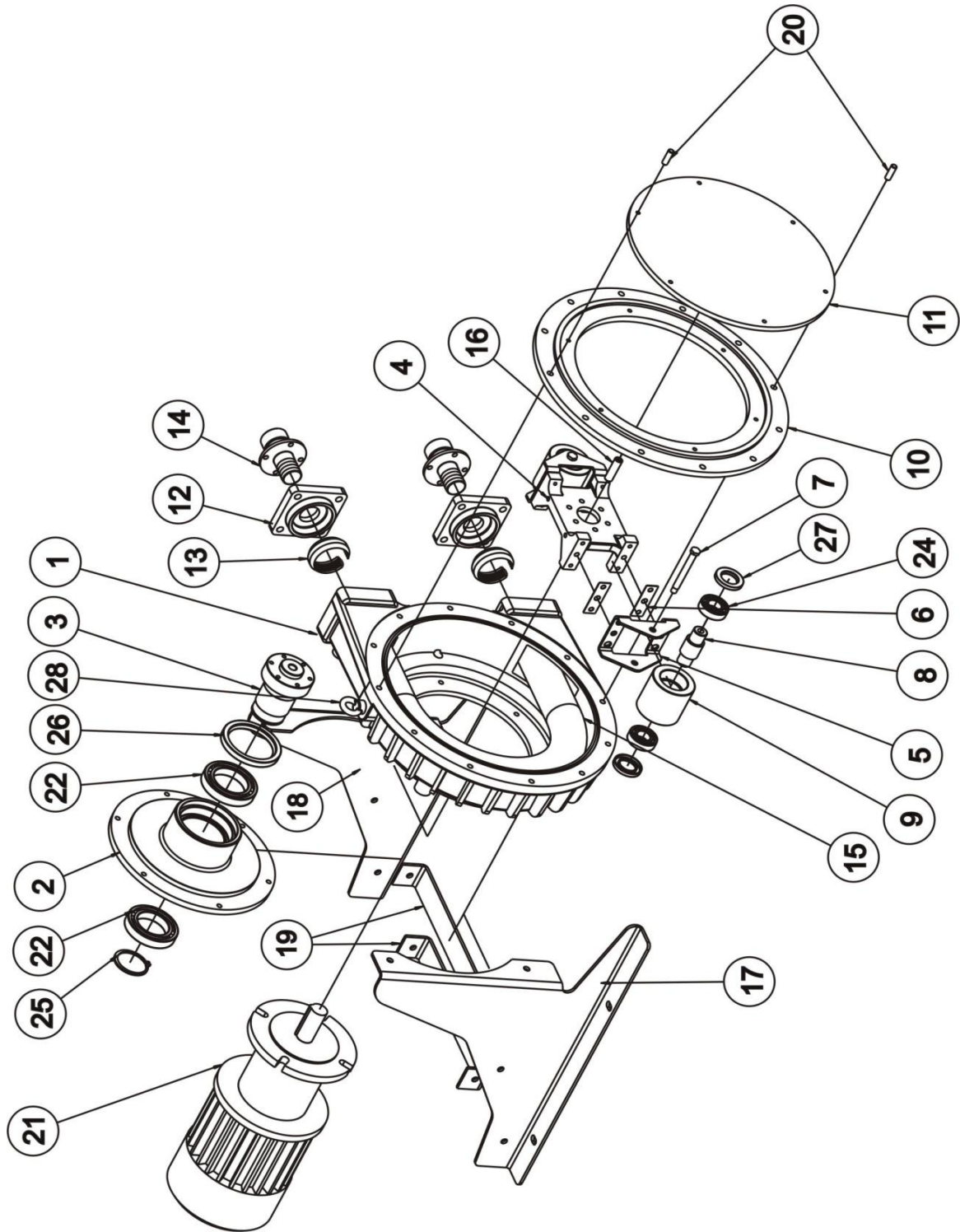

Pos.	Description	Quantity	Reference
1	Pump body	1	107.00.01
2	Ball bearing box	1	107.00.03
3	Rotor shaft	1	107.00.04
4	Rotor	1	107.00.05
5	Roller support	2	107.00.06
6	Shim		107.00.07
7	Shaft screw	2	107.00.08
8	Roller shaft	2	107.00.09
9	Roller	2	107.00.11
10	Metallic cover	1	107.00.13
11	Polycarbonate cover	1	107.00.14
12	Press flange	2	107.00.15
13	Press ring	2	100.00.05
14	Connection SS 1 1/4" BSP	2	107.00.17
	Connection SS 1 1/4" NPT	2	107.00.34
	Connection DIN 11851 NW32	2	107.00.35
	Connection TRI-CLAMP	2	107.00.36
	Connection flange DIN DN32 INOX	2	107.00.37
	Connection flange ANSI DN32 INOX	2	107.00.38
	Connection polypropylene 1 1/4" BSP	2	107.00.39
15	Peristaltic hose NR	1	107.00.18
	Peristaltic hose NR-A	1	107.00.19
	Peristaltic hose NBR	1	107.00.20
	Peristaltic hose NBR-A	1	107.00.21
	Peristaltic hose EPDM	1	107.00.22
16	Shaft cap	1	110.00.23
17	Base left	1	100.01.24
	Base left S.S	1	100.01.34
18	Base right	1	100.01.25
	Base right S.S		100.01.35
19	Base middle	2	100.01.26
	Base middle S.S		100.01.36
20	Stud	2	102.00.14
21	Driver	1	
22	Ball bearings	2	100.01.28
24	Ball bearings roller	4	107.00.30
25	Ring for shaft	1	100.01.31
26	Lip seal box	1	100.01.32

Pos.	Description	Quantity	Reference
27	Lip seal roller	4	107.00.33
28	Eye bolt	1	106.00.40
29	Drain plug FMP	3	107.00.41

8.2 Spare parts exploded FMP-40 Model

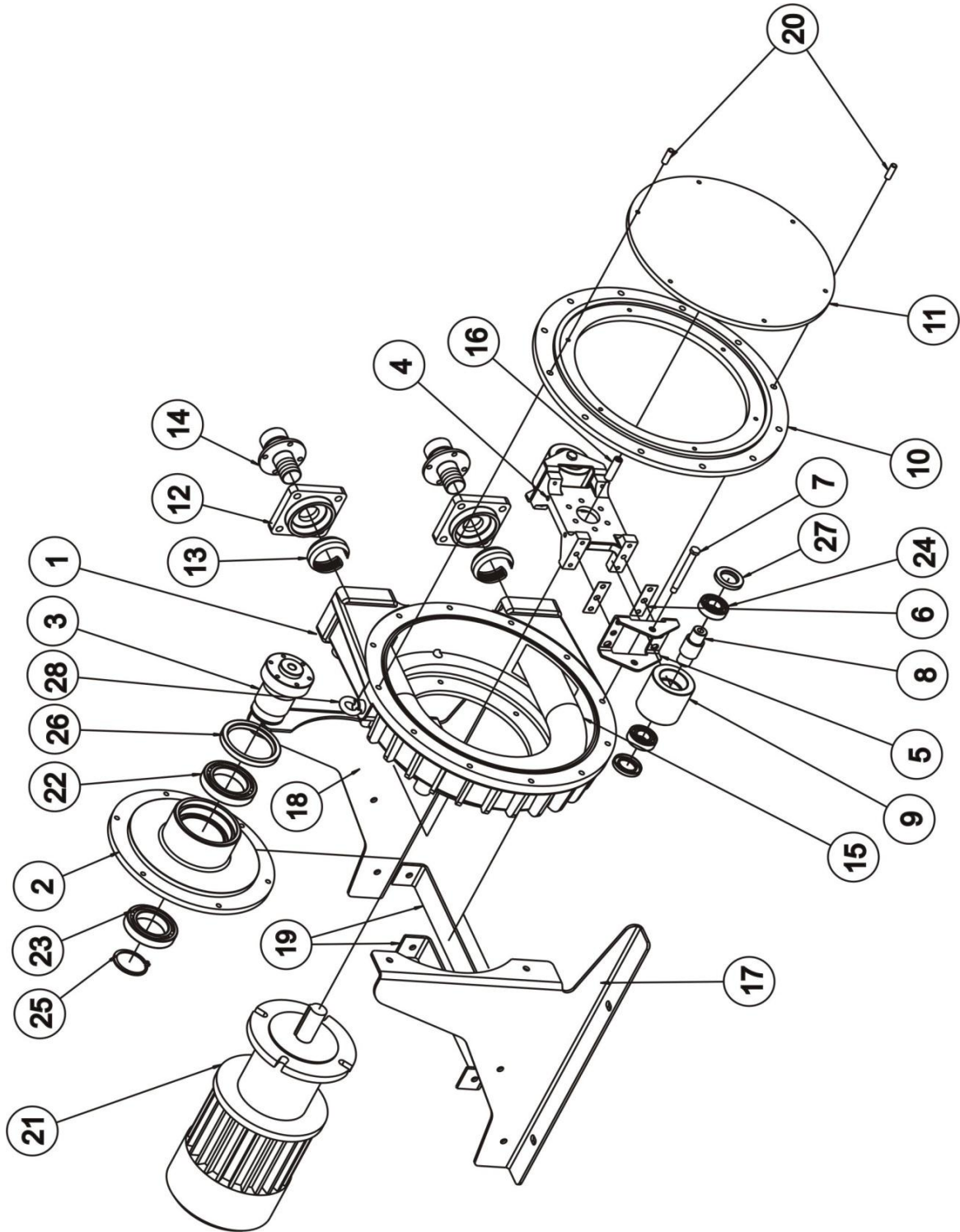

Pos.	Description	Quantity	Reference
1	Pump body	1	106.00.01
2	Ball bearing box	1	106.00.03
3	Rotor shaft	1	106.00.04
4	Rotor	1	106.00.05
5	Roller support	2	106.00.06
6	Shim 1mm		106.00.07
	Shim 4mm		106.00.49
7	Shaft screw	2	106.00.08
8	Roller shaft	2	106.00.09
9	Roller	2	106.00.11
10	Metallic cover	1	106.00.13
	Metallic cover vacuum equipment	1	106.00.43
11	Polycarbonate cover	1	106.00.14
12	Press flange	2	106.00.15
13	Press ring	2	104.00.05
	Press ring for NORPRENE hose	2	106.00.51
14	Connection SS 1 1/2" BSP	2	106.00.17
	Connection SS 1 1/2" NPT	2	106.00.34
	Connection DIN 11851 NW40	2	106.00.35
	Connection TRI-CLAMP	2	106.00.36
	Connection flange DIN DN40 INOX	2	106.00.37
	Connection flange ANSI DN40 INOX	2	106.00.38
	Connection Polypropylene 1 1/2" BSP	2	106.00.39
	Connection PVDF 1 1/2" BSP	2	106.00.41
	Connection Polypropylene 1 1/2" NPT	2	106.00.47
	Connection SMS-38	2	106.00.42
15	Peristaltic hose NR	1	106.00.18
	Peristaltic hose NR-A	1	106.00.19
	Peristaltic hose NBR	1	106.00.20
	Peristaltic hose NBR-A	1	106.00.21
	Peristaltic hose EPDM	1	106.00.22
	Peristaltic hose HYPALON	1	106.00.48
	Peristaltic hose NORPRENE	1	106.00.50
16	Shaft cap	1	106.00.23
17	Base left	1	106.00.24
	Base left S.S	1	106.00.44
	Base left trolley steel	1	106.00.52
	Base left trolley S.S	1	106.00.54

Pos.	Description	Quantity	Reference
18	Base right	1	106.00.25
	Base right S.S	1	106.00.45
	Base right trolley steel	1	106.00.53
	Base right trolley S.S	1	106.00.55
19	Base middle	2	106.00.26
	Base middle S.S	2	106.00.46
20	Stud	2	106.00.27
21	Driver	1	
22	Ball bearing anterior	1	106.00.28
23	Ball bearing posterior	1	106.00.29
24	Ball bearing roller	4	106.00.30
25	Ring for shaft	1	106.00.31
26	Lip seal box	1	106.00.32
27	Lip seal roller	4	106.00.33
28	Eye bolt	1	106.00.40
29	Drain plug FMP	3	107.00.41

8.3 Spare parts exploded FMP-50 Model

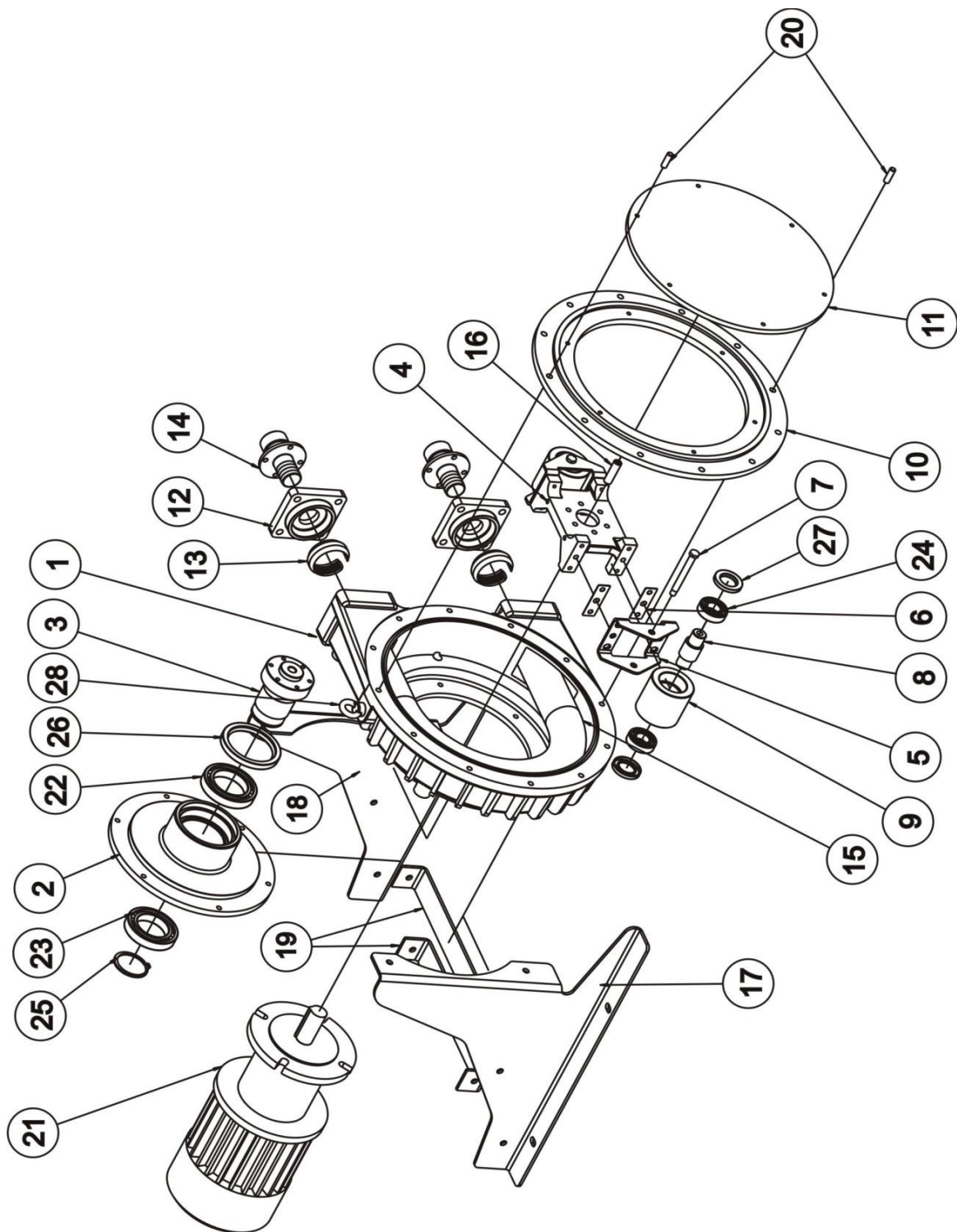

Pos.	Description	Quantity	Reference
1	Pump body	1	108.00.01
2	Ball bearing box	1	108.00.02
3	Rotor shaft	1	108.00.03
4	Rotor	1	108.00.04
5	Roller support	2	108.00.05
6	Shim		108.00.06
7	Shaft screw	2	108.00.07
8	Roller shaft	2	108.00.08
9	Roller	2	108.00.09
10	Metallic cover	1	108.00.10
11	Polycarbonate cover	1	108.00.39
12	Press flange	2	108.00.11
13	Press ring	2	108.00.12
14	Connection flange DN50 S.S	2	108.00.13
	Connection ANSI flange DN-50 SS	2	108.00.14
	Connection flange DN50 PP	2	108.00.16
	Connection ANSI flange DN-50 PP	2	108.00.17
	Connection flange DN-50 PVDF	2	108.00.18
	Connection ANSI flange DN-50 PVDF	2	108.00.19
	Connection DIN 11851 NW-50	2	108.00.15
	Connection TRI-CLAMP	2	
15	Peristaltic hose NR	1	108.00.20
	Peristaltic hose NR-A	1	108.00.21
	Peristaltic hose NBR	1	108.00.22
	Peristaltic hose NBR-A	1	108.00.23
	Peristaltic hose EPDM	1	108.00.24
	Peristaltic hose HYPALON	1	108.00.25
16	Shaft cap	1	
17	Base left	1	108.00.26
	Base left S.S	1	108.00.36
18	Base right	1	108.00.27
	Base right S.S	1	108.00.37
19	Base middle	2	108.00.28
	Base middle S.S	2	108.00.38
20	Stud	2	
21	Driver	1	
22	Ball bearing anterior	1	108.00.29
23	Ball bearing posterior	1	108.00.30

Pos.	Description	Quantity	Reference
24	Ball bearing roller	4	108.00.31
25	Ring for shaft	1	108.00.32
26	Lip seal box	1	108.00.33
27	Lip seal roller	4	108.00.34
28	Eye bolt	1	
29	Drain plug FMP-50	3	
30	O-Ring front cover	1	108.00.35
31	Lateral rotor	2	108.00.44

8.4 Spare parts exploded FMP-60 Model

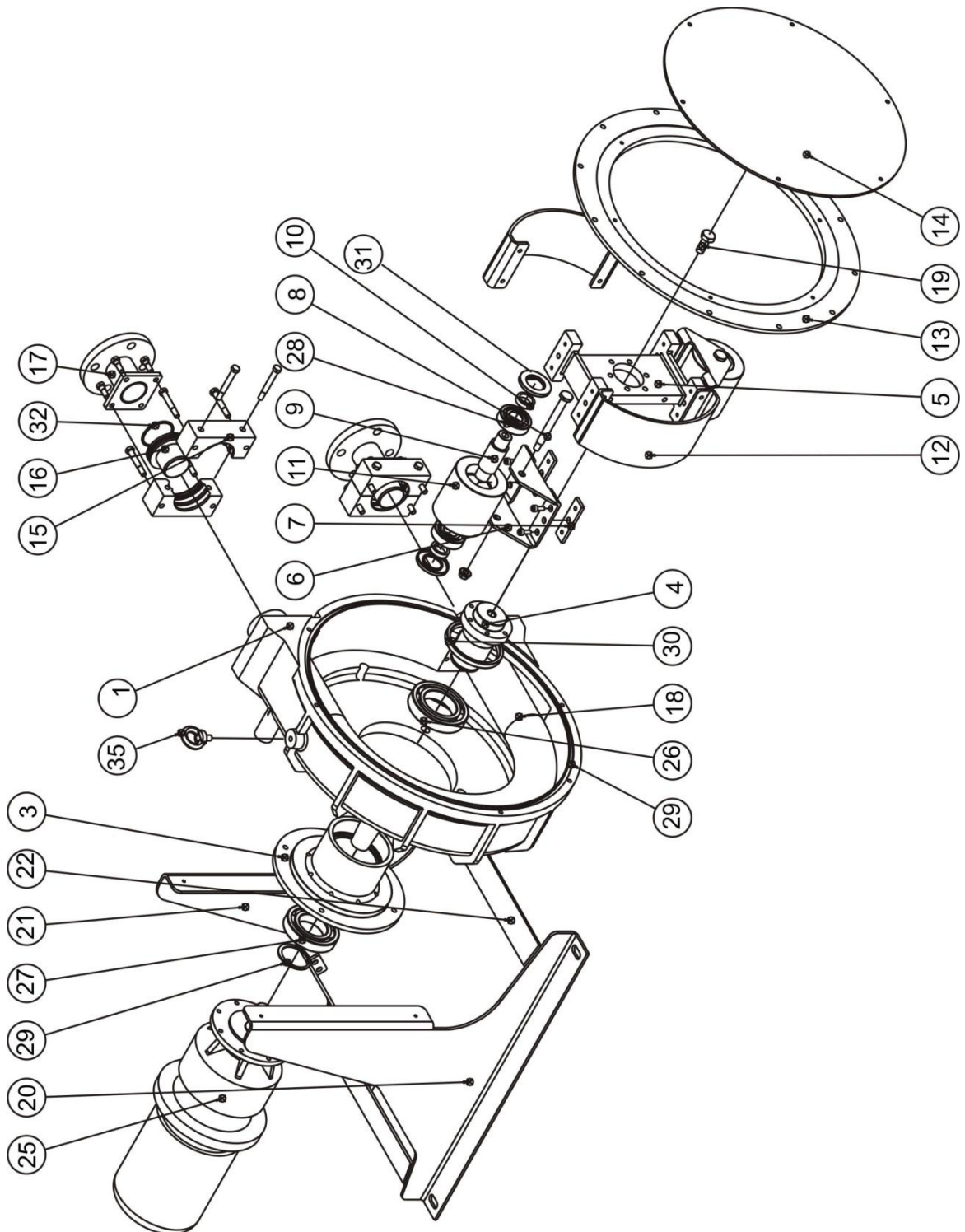

Pos.	Description	Quantity	Reference
1	Pump body	1	110.00.01
3	Ball bearing box	1	110.00.03
4	Rotor shaft	1	110.00.04
5	Rotor	1	110.00.05
6	Roller support	2	110.00.06
7	Shim 1mm		110.00.07
	Shim 7mm		110.00.55
	Shim 5mm		110.00.56
8	Shaft screw	2	110.00.08
9	Roller shaft	2	110.00.09
10	Separator	4	110.00.10
11	Roller	2	110.00.11
12	Lateral rotor	2	110.00.12
13	O-ring cover	1	110.00.13
14	Front cover transparent	1	110.00.14
15	Press flange	2	110.00.15
16	Insert S.S	2	110.00.16
	Insert Polypropylene	2	110.00.46
	Insert PVDF	2	110.00.47
17	Connection flange DIN	2	110.00.17
	Connection flange ANSI	2	110.00.41
	Connection TRI-CLAMP	2	110.00.42
	Connection DIN 11851	2	110.00.43
	Connection flange DIN (Halar)	2	110.00.44
	Connection flange ANSI (Halar)	2	110.00.45
18	Peristaltic hose NR	1	110.00.18
	Peristaltic hose NR-A	1	110.00.19
	Peristaltic hose NBR	1	110.00.20
	Peristaltic hose NBR-A	1	110.00.21
	Peristaltic hose EPDM	1	110.00.22
	Peristaltic hose HYPALON	1	110.00.54
19	Bearing box cap	1	110.00.23
20	Base left	1	110.00.37
	Base left S.S	1	110.00.48
21	Base right	1	110.00.38
	Base right S.S	1	110.00.49
22	Base middle 100mm	1	110.00.39
	Base middle S.S 100mm	1	110.00.50

Pos.	Description	Quantity	Reference
23	Base middle 60mm	2	110.00.40
	Base middle S.S 60mm	2	110.00.51
24	Stud	2	106.00.27
25	Driver	1	
26	Ball bearing anterior	1	110.00.26
27	Ball bearing posterior	1	110.00.27
28	Roller ball bearing	4	110.00.28
29	Elastic Ring for shaft	1	110.00.29
30	Bearing box lip seal	1	110.00.30
31	Roller lip seal	1	110.00.31
32	O-ring connection	2	110.00.32
34	O-ring cover	1	110.00.33
35	Eye bolt	1	110.00.34
36	Nut	2	110.00.35
37	Nut	2	110.00.36
38	Drain plug FMP	3	107.00.41
39	Check valve	1	110.00.53

8.5 Spare parts exploded FMP-70 Model

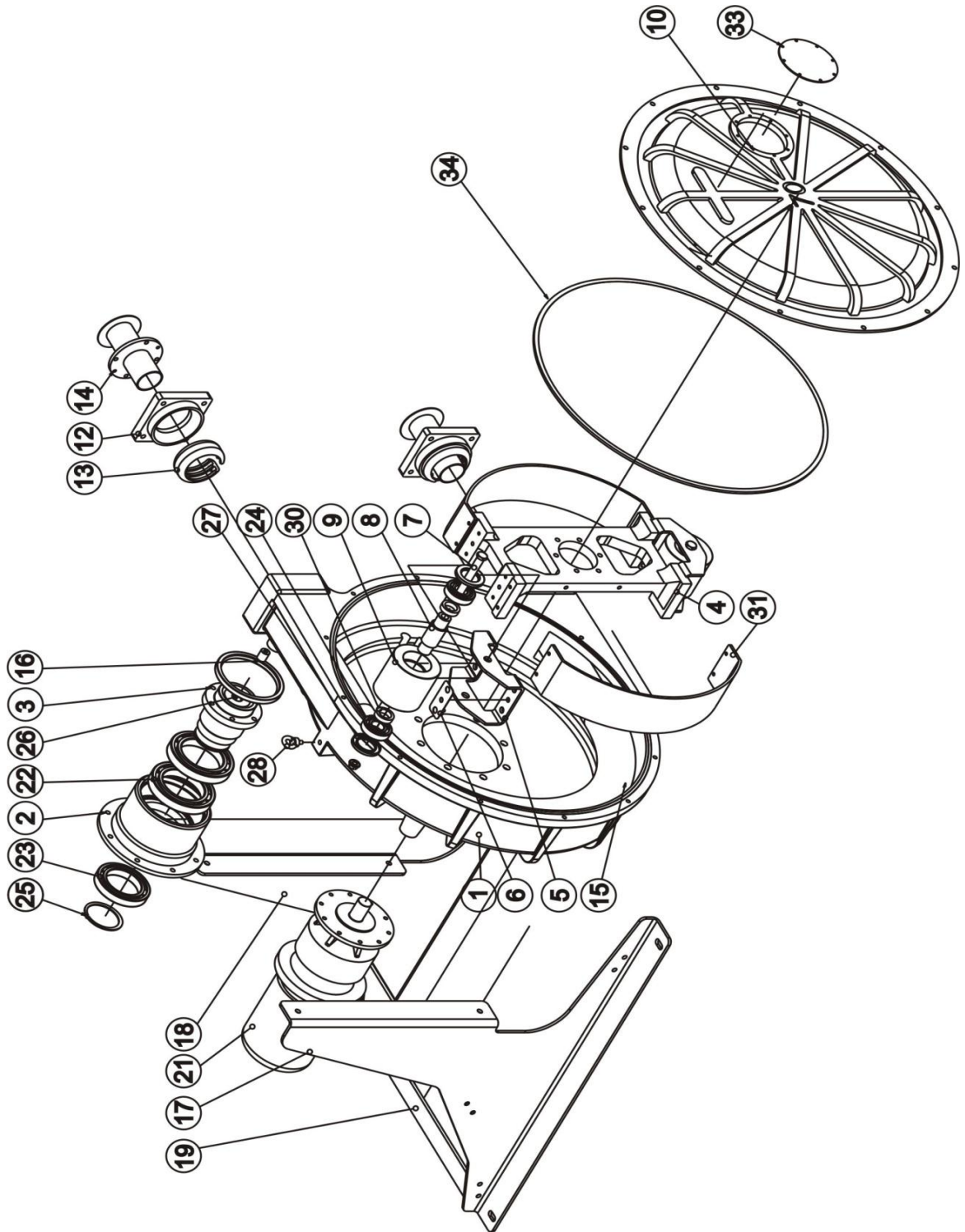

Pos.	Description	Quantity	Reference
1	Pump body	1	112.00.01
2	Ball bearing box	1	111.00.03
3	Rotor shaft	1	111.00.04
4	Rotor	1	112.00.02
5	Roller support	2	112.00.03
6	Shim		112.00.04
7	Shaft screw	2	112.00.05
8	Roller shaft	2	112.00.06
9	Roller	2	112.00.07
10	Front cover	1	112.00.08
12	Press flange	2	112.00.09
13	Press ring	2	112.00.10
14	Connection DIN flange S.S	2	112.00.11
	Connection ANSI flange S.S	2	112.00.12
	Connection DIN 11851 NW-65	2	112.00.13
	Connection DIN flange PP	2	112.00.14
	Connection ANSI flange PP	2	112.00.15
	Connection DIN flange PVDF	2	112.00.16
	Connection ANSI flange PVDF	2	112.00.17
	Connection TRI-CLAMP	2	112.00.43
15	Peristaltic hose NR	1	112.00.18
	Peristaltic hose NR-A	1	112.00.19
	Peristaltic hose NBR	1	112.00.20
	Peristaltic hose NBR-A	1	112.00.21
	Peristaltic hose EPDM	1	112.00.22
	Peristaltic hose HYPALON	1	112.00.23
16	Shaft cap	1	111.00.08
17	Base left	1	112.00.24
	Base left S.S		112.00.36
18	Base right	1	112.00.25
	Base right S.S	1	112.00.37
19	Base middle	2	112.00.26
	Base middle S.S	2	112.00.38
20	Stud	2	112.00.44
21	Driver	1	
22	Ball bearing anterior	2	111.00.28
23	Ball bearing posterior	1	111.00.29
24	Ball bearing roller	4	112.00.27

Pos.	Description	Quantity	Reference
25	Ring for shaft	1	111.00.30
26	Lip seal box	1	111.00.31
27	Lip seal roller	4	112.00.28
28	Eye bolt	1	112.00.29
29	Drain plug FMP-70	3	112.00.30
30	Roller ferrule	2	112.00.31
31	Lateral rotor	2	112.00.32
32	Inspection window (fixed model)	1	112.00.33
33	Inspection window (movil model)	1	112.00.34
34	O-ring front cover	1	112.00.35

8.6 Spare parts exploded FMP-70D Model

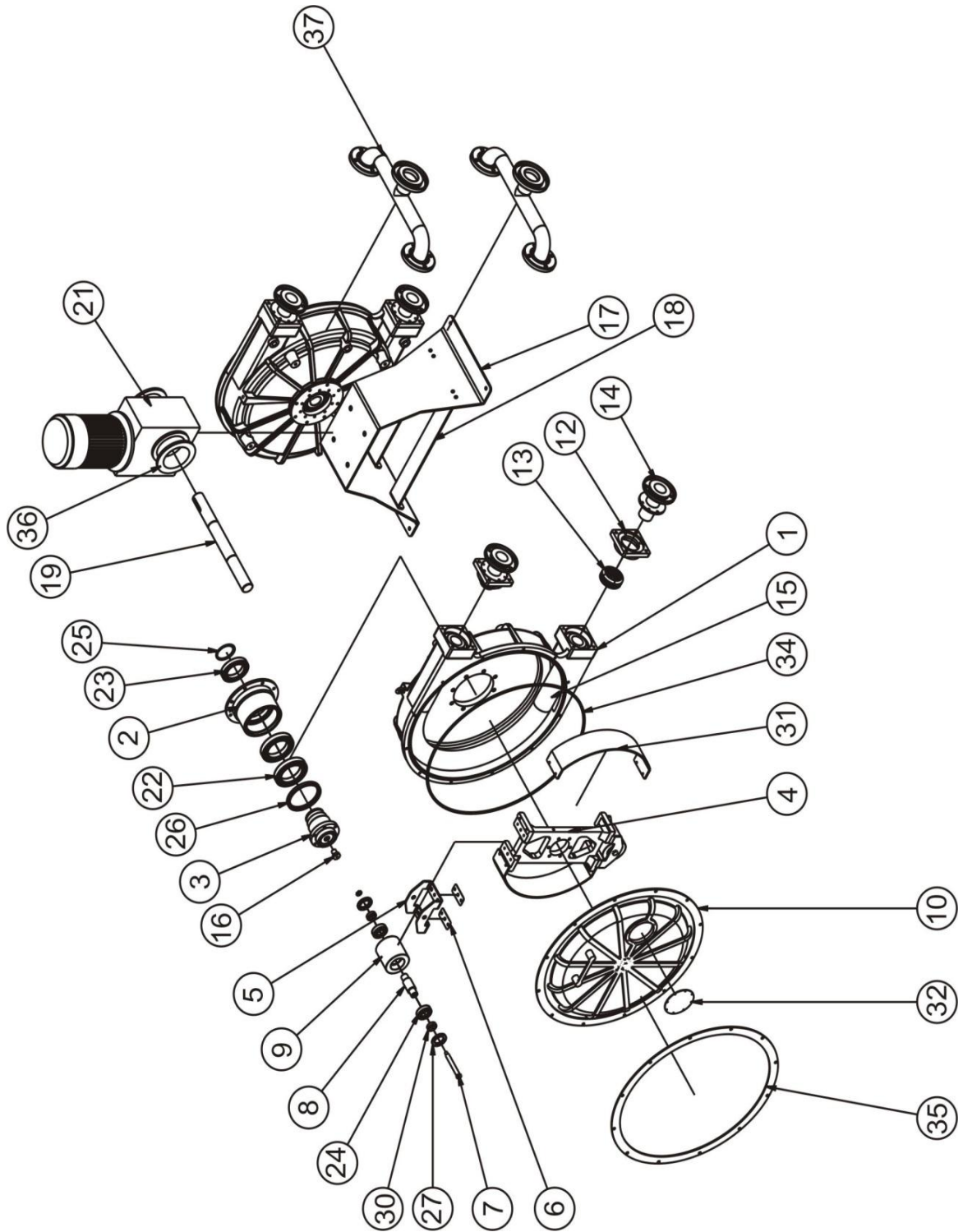

Pos.	Description	Quantity	Reference
1	Pump body	2	112.00.01
2	Ball bearing box	2	111.00.03
3	Rotor shaft	2	111.00.04
4	Rotor	2	112.00.02
5	Roller support	4	112.00.03
6	Shim		112.00.04
7	Shaft screw	4	112.00.05
8	Roller shaft	4	112.00.06
9	Roller	4	112.00.07
10	Front cover	2	112.00.08
12	Press flange	4	112.00.09
13	Press ring	4	112.00.10
14	Connection DIN flange S.S	4	112.00.11
	Connection ANSI flange S.S	4	112.00.12
15	Peristaltic hose NR	2	112.00.18
	Peristaltic hose NR-A	2	112.00.19
	Peristaltic hose NBR	2	112.00.20
	Peristaltic hose NBR-A	2	112.00.21
	Peristaltic hose EPDM	2	112.00.22
	Peristaltic hose HYPALON	2	112.00.23
16	Shaft cap	2	111.00.08
17	Base	1	112.00.48
	Base S.S	1	112.00.53
18	Base middle	2	112.00.49
	Base middle S.S	2	112.00.54
19	Dual shaft	1	112.00.46
20	Stud	4	112.00.44
21	Driver	1	
22	Ball bearing anterior	4	111.00.28
23	Ball bearing posterior	1	111.00.29
24	Ball bearing roller	4	112.00.27
25	Ring for shaft	2	111.00.30
26	Lip seal box	2	111.00.31
27	Lip seal roller	8	112.00.28
28	Eye bolt	2	112.00.29
29	Drain plug FMP-70	6	112.00.30
30	Roller ferrule	4	112.00.31
31	Lateral rotor	4	112.00.32

Pos.	Description	Quantity	Reference
32	Inspection window (fixed model)	2	112.00.33
33	Inspection window (mobile model)	2	112.00.34
34	O-ring front cover	2	112.00.35
35	Metallic cover ring	1	112.00.51
36	Gear reducer coupling	2	112.00.47
37	Collector DIN S.S	2	112.00.50
	Collector ANSI S.S	2	112.00.53

9. Declaration of Conformity

- Original-

EC Declaration of Conformity

We hereby declare,

BOMBAS BOYSER S.L
C/ Narcís Monturiol, 24 – Pol. Ind. Can Magre
08187 – Sta. Eulàlia de Ronçana (Barcelona)
Spain

That the following designated product complies with the pertinent fundamental safety and health requirements of the EC Directive in terms of its design and construction and in terms of the version marketed by us.

This declaration loses its validity in the event of a modification to the product not agreed with us.

Description of the product: Peristaltic pump BOYSER FMP

Product type: FMP-30, FMP-40, FMP-50, FMP-60, FMP-70, FMP-70D

Serial no.: Refer to nameplate on the device

Pertinent EC Directives: **CE Declaration of Conformity (Ann. II. A, 2006/42/CE):** The pump is conform to the safety requirements according to the 2006/42/CE norms and amendments

Manufacture Declaration (Ann. II. B, 2006/42/CE): The pump cannot be operated before the machine in which is assembled the pump, will be declared in conformity with the safety requirements according to the 2006/42/CE norms and amendments.

Signature:



Details of the signatory:

Technical Manager

10. Guarantee

We guarantee against all manufacturing defects and guarantee the materials that compose the electro pump BOYSER for one year from the date of delivery. This guarantee does not include the hose or the lubricant as these are elements that have a normal function wear, irrespective of their duration.

This guarantee is valid as long as the equipment functions within the parameters indicated in the technical information card supplied with every pump or on subsequent changes authorized by BOMBAS BOYSER S.L.

This guarantee includes materials and work but not the transportation of materials to or from our warehouses in Santa Eulàlia de Ronçana (Barcelona), being necessary to do so arising from the necessities of the client, the corresponding costs of displacement and expenses will be charged.