

# NOVADOS

DIAPHRAGM AND PLUNGER METERING PUMPS



Part of SPX Corporation (NYSE: SPW), the Flow Technology segment designs, manufactures, installs and services highly engineered solutions used to process, blend, meter and transport fluids, in addition to air and gas filtration and dehydration. The segment supports the food and beverage, dairy, pharmaceutical, oil and gas, energy, and industrial markets worldwide.

Based in Charlotte, North Carolina, SPX Corporation (NYSE: SPW) is a global Fortune 500 multi-industry manufacturing leader with over \$5 billion in annual revenue, operations in more than 35 countries and over 15,000 employees. The company's highly-specialized, engineered products and technologies are concentrated in Flow Technology and energy infrastructure. Many of SPX's innovative solutions are playing a role in helping to meet rising global demand for electricity and processed foods and beverages, particularly in emerging markets. The company's products include food processing systems for the food and beverage industry, power transformers for utility companies, and cooling systems for power plants. For more information, please visit [www.spx.com](http://www.spx.com).

For more than 75 years, Bran+Luebbe - now SPX Flow Technology – has been providing customers with high quality metering, processing and analysing equipment.

As part of the global SPX Corporation, we are one of the world's most reputable manufacturers of metering and process pumps, process systems as well as analyzing technologies. Our engineers have comprehensive process and applications knowledge across a wide range of markets. This has resulted in product innovations and developments which harness the latest technology whilst meeting the highest quality standards.

## NOVADOS - A Selection of Metering Pumps Beyond Compare

With NOVADOS metering pumps we offer a wide range for virtually all applications where liquids have to be metered or blended.

The product range comprises leak-free diaphragm pumps as well as plunger pumps.

### COMMON DESIGN FEATURES

- Modular metering pump gears with built-in low noise worm gear
- Individual stroke length setting utilizing the z-shaped crankshaft
- Range of pump head sizes to allow a flow range of between smallest 0.4 l/h up to largest 20,000 l/h on a single head
- Operating pressure up to 1,000 bar
- Manual or automatic flow rate adjustment

### ADVANTAGES

#### FLEXIBLE

- Optimal capacity adaptation to widely varying production processes
- Variable stroke length for each pump allows independent flow rate adjustment of each pump component
- Variable speed drive allows flow rate variations while maintaining constant proportions

#### ECONOMICAL

- Automation allows higher production efficiency to be achieved

#### ADAPTABLE

- Existing installations can be altered or expanded with extra pumps or automatic control



Horizontal metering pump with diaphragm pump head



Horizontal metering pump with multiple diaphragm pump heads

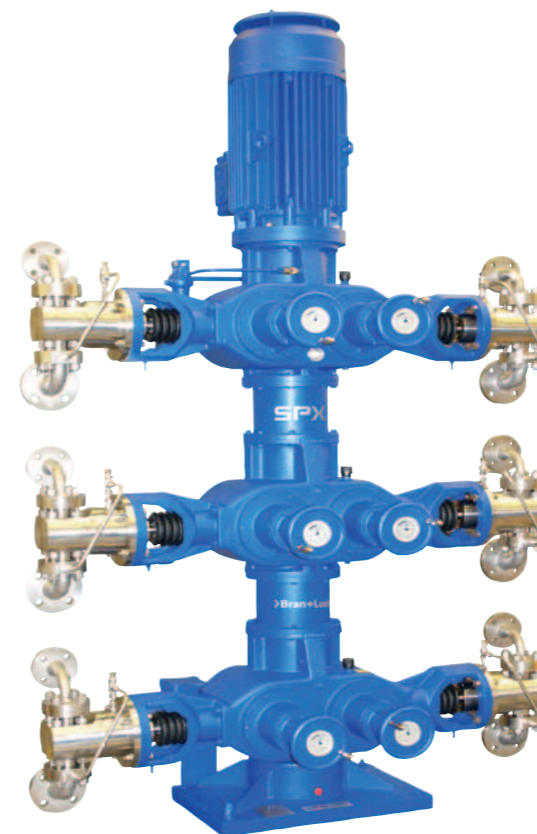

Vertical metering pump with multiple plunger pump heads

## Applications

### CHEMICAL PROCESSING

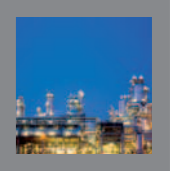

### OIL & GAS



### POWER & ENERGY



### PHARMACEUTICAL & BIOTECHNOLOGY



### TEXTILE



### WATER TREATMENT



### PERSONAL CARE



# Concept of the Bran+Luebbe NOVADOS Metering Pumps

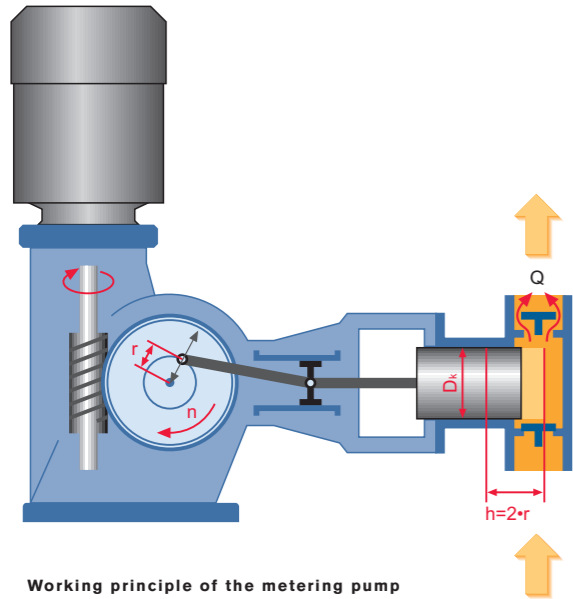

Working principle of the metering pump

## WORKING PRINCIPLE OF THE METERING PUMP

Reciprocating pumps are normally comprised of a motor, gearbox and pump head.

The gear reduces the motor speed and converts the rotary motion into a reciprocating movement of a plunger in the pump head.

Flow rate of a reciprocating pump is defined by the plunger diameter, stroke length and stroking speed.

Setting the flow rate of a metering pump can be achieved by changing the speed of the drive motor or - as described below - via an adjustment of the stroke length.

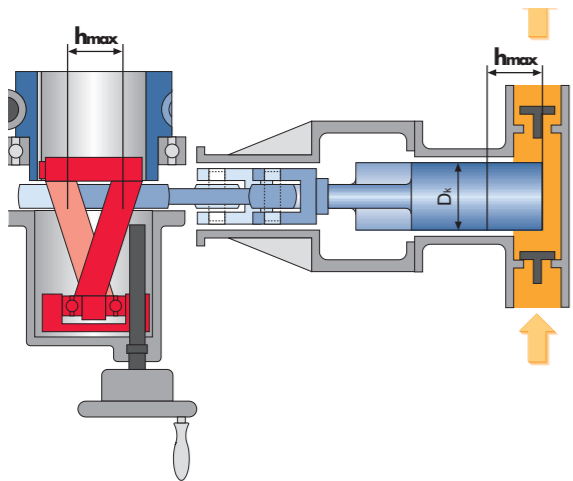

Principle of a flow rate adjustment

## SIMPLY EFFECTIVE: FLOW RATE ADJUSTMENT BY THE Z-SHAPED CRANKSHAFT

Flow rate can be adjusted linearly between zero and maximum by altering the position of the z-shaped crankshaft. This design allows adjustment while the pump is operating or at standstill.

Bran+Luebbe NOVADOS metering pumps exceed the requirements of API 675 in terms of metering accuracy, linearity and reproducibility.

## PLUNGER PUMPS

- Low investment costs
- Simple design
- Easy maintenance

## DIAPHRAGM PUMPS

A leak-proof pump is the right choice whenever product purity or sterility are imperative or when toxic liquids must be handled.

SPX Flow Technology offers a wide range of hydraulically actuated double diaphragm pumps.

The design of the pump head ensures that the diaphragm cannot be damaged under critical conditions such as a blocked pipe or closed valves upstream or downstream of the pump.

The freely deflecting diaphragm makes the pump suitable for the metering of slurries.

## NOVADOS DIAPHRAGM PUMPS: FEATURES

- Diaphragm position control for maximum operating security
- Operating pressure (PTFE diaphragm) up to 400 bar
- Operating pressure (metallic diaphragm) up to 1000 bar
- Fluid temperature up to 150°C
- Safe dry-run capabilities
- High volumetric efficiency
- High metering accuracy
- Hermetically sealed by two diaphragm layers
- Diaphragm condition monitoring
- NOVALINK CSM 2 Diagnosis interface as standard
- Specific customer requirements on request

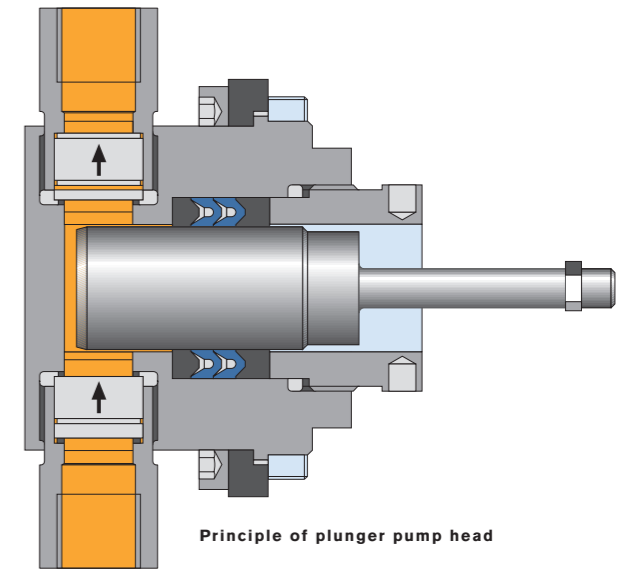

Principle of plunger pump head

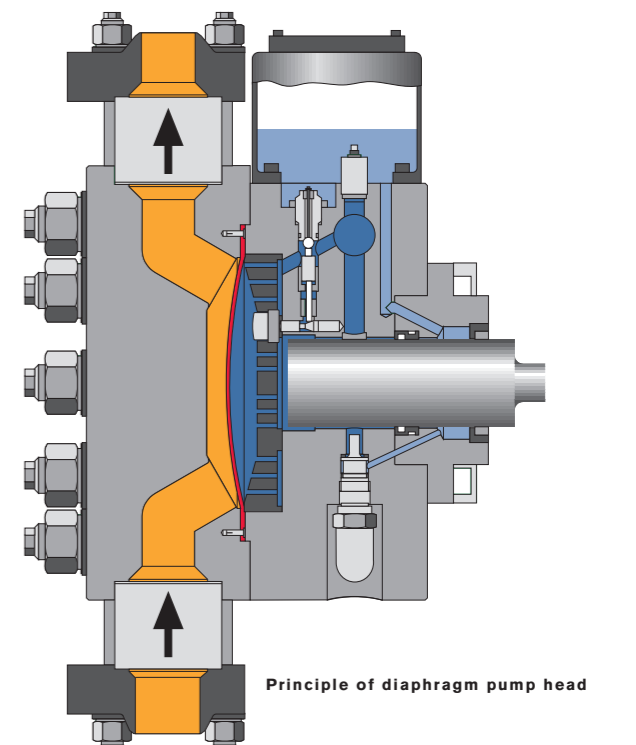

Principle of diaphragm pump head

# Concept of the Bran+Luebbe NOVADOS Metering Pumps

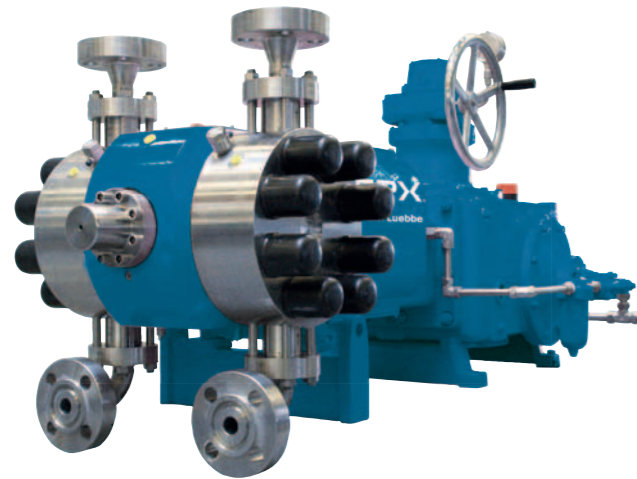

Metering pump with double-acting diaphragm pump head

## DOUBLE-ACTING DIAPHRAGM PUMPS

The double-acting diaphragm pump head offers the benefit of twice the flow rate on a single gearbox whilst maintaining the same metering accuracy

### ADVANTAGES

- Doubled flow rate
- Less foot print required compared with conventional duplex pumps

## OPTIONS FOR STROKE LENGTH ADJUSTMENT

### MANUAL

- with integrated scale

### ELECTRIC

- direct remote control
- with input signal 0/4...20 mA
- with electronic control card

### PNEUMATIC

- with input signal 0.2 ... 1 bar
- with input signal 0/4 ... 20 mA



Metering pump with plastic diaphragm pump head and pneumatic flow rate control

# NOVADOS-Solutions

## OPTIONS TO SUIT SPECIAL APPLICATIONS

### PUMP HEAD OPTIONS (ON REQUEST)

- Heating or cooling jackets (valve heating possible)
- Quick-release valves
- Remote valves
- Optimised flow channels for slurries or viscous fluids

### VALVE DESIGNS

- Ball valves (single, double or triple)
- Cone valves with or without spring
- Plate valves

### MATERIALS OF CONSTRUCTION FOR

#### LIQUID-WETTED PARTS OF THE PUMP

- Housings of stainless steel 1.4571 or 1.4462 alternatively PVC or PVDF
  - Diaphragms of PTFE or stainless steel 1.4310
  - Plungers of stainless steel, ceramic, tungsten carbide
  - Valves of stainless steel, plastic or hard metals
- Special materials available upon request

## HORIZONTAL OR VERTICAL COMBINATIONS

SPX Flow Technology is the only pump manufacturer worldwide to offer both vertical and horizontal combinations of metering pumps.

Possible equipment combinations range from simplex pumps to multiplex pumps with different pump heads, each of them can be controlled independently.

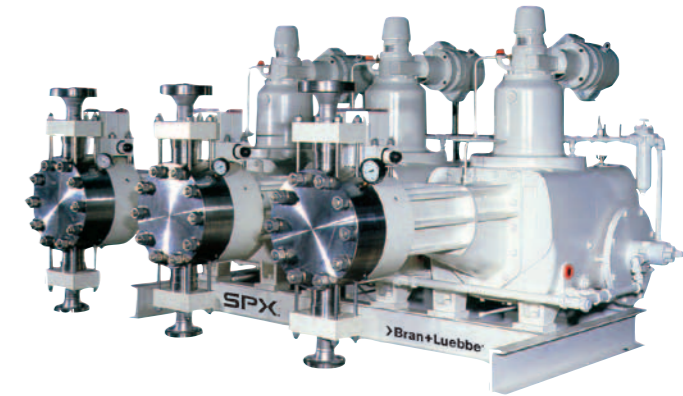

Process metering pump with diaphragm pump head and electric stroke length adjustment

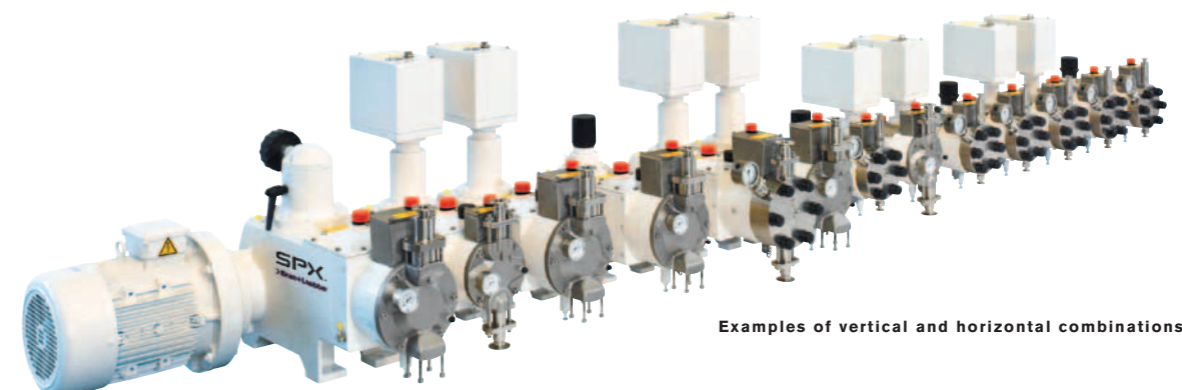

Examples of vertical and horizontal combinations

**THE PRODUCT RANGE: MORE EXAMPLES OF BRAN+LUEBBE PRODUCTS WITH HIGH QUALITY STANDARD, INNOVATION AND KNOW-HOW.**



**Metering pumps**  
for universal applications  
in the low to medium  
requirement range  
ProCam  
ProCam Smart  
ProCam Hygienic



**Process pumps**  
for large flow rates and  
high operating pressures  
NOVAPLEX  
MEGANIZER  
High pressure homogenizer



**Dynamic in-line mixer**  
for gentle but intensive  
mixing  
PENTAX  
PENTAX Hygienic



**Process systems**  
as a complete solution for  
increased productivity and  
quality  
AutoBlend  
Metering and mixing systems

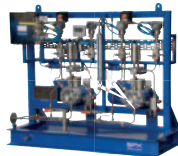

**Oil & Gas systems**  
to aid oil & gas recovery  
onshore and offshore  
Solar Panel Packages  
Chemical Injection Systems  
Flow Control Device Panels



**On-line analyzers**  
for use in water  
and effluent treatment  
PowerMon  
PowerMon S  
PowerMon Compact

## Global locations

### EMEA

#### SPX FLOW TECHNOLOGY

Werkstraße 4  
D-22844 Norderstedt  
Phone: +49 (0) 40 - 522 02 -0  
Fax: +49 (0) 40 - 522 02 -444  
E-Mail: branluebbe@spx.com

#### SPX FLOW TECHNOLOGY

Ironstone Way  
Brixworth, Northants, NN6 9UD  
Phone: +44 (0) 1604 880751  
Fax: +44 (0) 1604 880145  
E-Mail: ft.brixworth.sales@spx.com

### AMERICAS

#### SPX FLOW TECHNOLOGY

611 Sugar Creek Road  
Delavan, WI 53115 USA  
Phone: +1 (800) 252-5200 or  
+1 (262) 728-1900  
Fax: +1 (262) 728-4904  
E-Mail: branluebbe@spx.com

### APAC

#### SPX FLOW TECHNOLOGY

25 International Business Park  
#03-03/12, German Centre,  
Singapore 609916  
Phone: +65 6568 1568  
Fax: +65 6265 9133  
E-Mail: asia.pacific@spx.com

#### SPX FLOW TECHNOLOGY NORDERSTEDT GMBH

Werkstraße 4  
D-22844 Norderstedt  
Phone: +49 (0) 40 - 522 02 -0  
Fax: +49 (0) 40 - 522 02 -444  
E-Mail: branluebbe@spx.com

SPX reserves the right to incorporate our latest design and material changes without notice or obligation.

Design features, materials of construction and dimensional data, as described in this bulletin, are provided for your information only and should not be relied upon unless confirmed in writing. Please contact your local sales representative for product availability in your region. For more information visit [www.spx.com](http://www.spx.com).

"The green ">" is a trademark of SPX Corporation, Inc."