

**FLEXCORE** Series

Technically superior.

Patented easy-to-change cartridge technology



Made in  
Germany

# FLEXCORE | The first pump that is adaptable.

The FLEXCORE pump family is the next evolutionary stage in the pump sector. Thanks to the unique modularity of the housing and the **patented pump insert**, it can adapt flexibly to any installation position and standard. FLEXCORE provides a higher flow rate at a smaller size. Extremely robust, **virtually wear-free**, and uniquely easy to maintain.

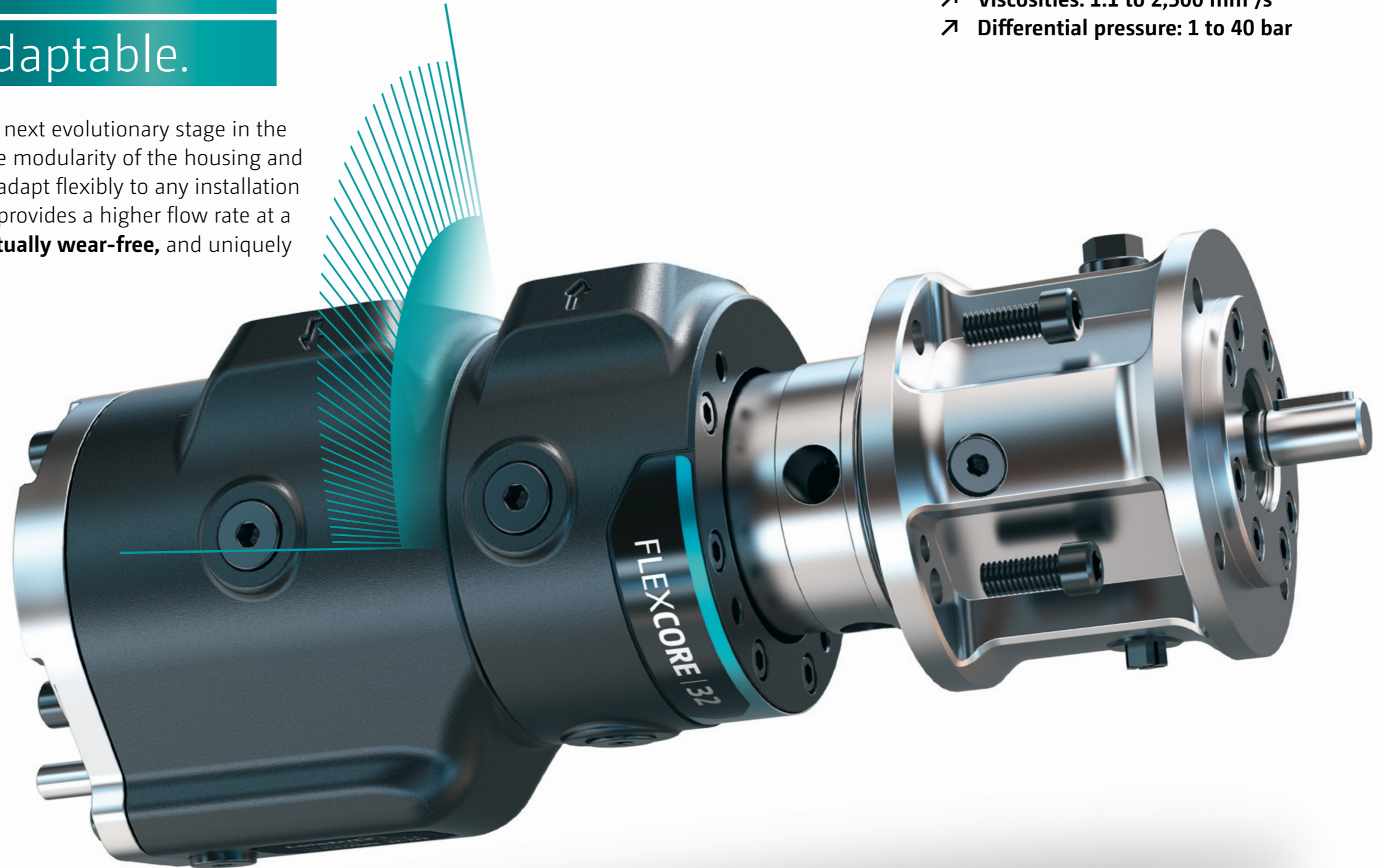

- ↗ Low-pulsation flow rates: 7–564 l/min
- ↗ Viscosities: 1.1 to 2,500 mm<sup>2</sup>/s
- ↗ Differential pressure: 1 to 40 bar

## Maximum flexibility

Flexible to install due to the 4 x 90° turnable, split pump casing. Perfect for every application, with up to 20 different flow directions and 6 flow rate categories.

## Technically superior

Superior performance data provide maximum operational reliability in an extremely wide range of applications. For example, during operation at a pressure of up to 40 bar or a differential pressure of 10 bar, at a viscosity of only 1.1 mm<sup>2</sup>/s.

## Digital early detection

With the “Smart Pump Sensor”, the pumps can be monitored and their data evaluated at any time. E.g. for maintenance based on operating hours, early fault detection, and fault cause analysis.

## Short delivery times

The unique modular design allows the pumps to be delivered **from stock** within a very short time.

Available with cast and steel casings — 24-month warranty

FLEXCORE is available with steel casing (SC) and cast casing (CC), each with 6 categories of low-pulsation flow rates from 7 to 564 liters per minute.

# FLEXCORE | Patented easy-to-change cartridge technology

The easy-to-change cartridge technology makes changing the pump insert faster and easier than ever. In combination with the proverbial Leistriz quality, which is virtually wear-free, FLEXCORE stands for maximum system availability. Made for demanding applications in the naval, energy, mechanical engineering, oil, and chemical sectors.

**Made in Germany.**

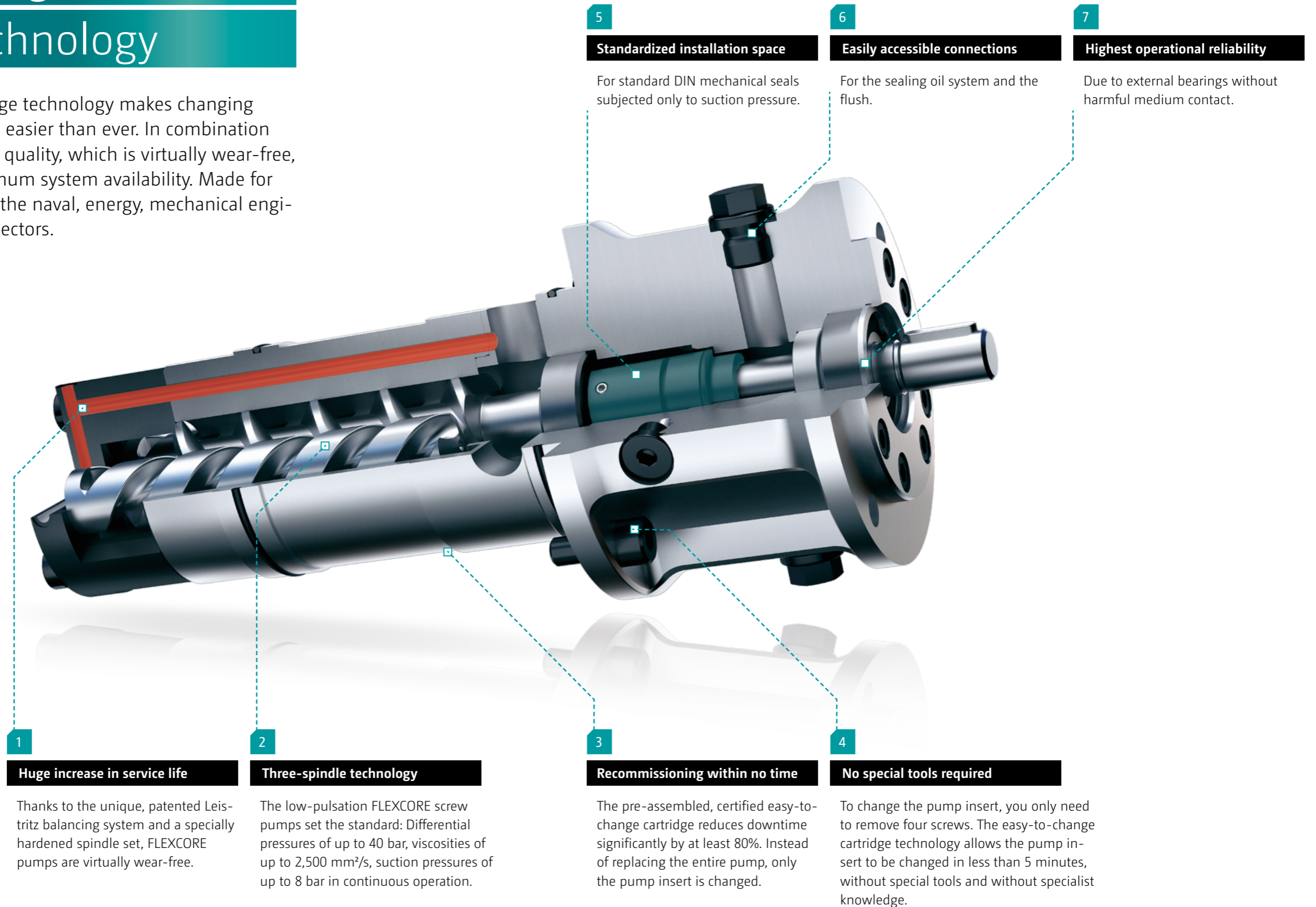

## Sophisticated down to the last detail

**1**  
**Huge increase in service life**

Thanks to the unique, patented Leistriz balancing system and a specially hardened spindle set, FLEXCORE pumps are virtually wear-free.

**2**  
**Three-spindle technology**

The low-pulsation FLEXCORE screw pumps set the standard: Differential pressures of up to 40 bar, viscosities of up to 2,500 mm<sup>2</sup>/s, suction pressures of up to 8 bar in continuous operation.

**3**  
**Recommissioning within no time**

The pre-assembled, certified easy-to-change cartridge reduces downtime significantly by at least 80%. Instead of replacing the entire pump, only the pump insert is changed.

**4**  
**No special tools required**

To change the pump insert, you only need to remove four screws. The easy-to-change cartridge technology allows the pump insert to be changed in less than 5 minutes, without special tools and without specialist knowledge.

**5**  
**Standardized installation space**

For standard DIN mechanical seals subjected only to suction pressure.

**6**  
**Easily accessible connections**

For the sealing oil system and the flush.

**7**  
**Highest operational reliability**

Due to external bearings without harmful medium contact.

## FLEXCORE SC (steel casing)

Coated in steel for  
the highest standard.



## FLEXCORE CC (cast casing)

Cast casing for an extremely  
wide range of applications.



	FLEXCORE SC Series
Flow rates	6 flow rate categories between 7 - 564 l/min
Viscosity	1.1 to 2,500 mm <sup>2</sup> /s
Operating temperature	-10 to 180 °C
Differential pressure	1 to 40 bar
Suction pressure	max. 8 bar

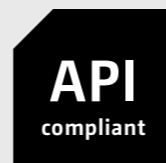

	FLEXCORE CC Series
Flow rates	6 flow rate categories between 7 - 564 l/min
Viscosity	1.1 to 2,500 mm <sup>2</sup> /s
Operating temperature	-10 to 180 °C
Differential pressure	1 to 40 bar
Suction pressure	max. 8 bar

# FLEXCORE CC

Maximum availability

meets maximum power.

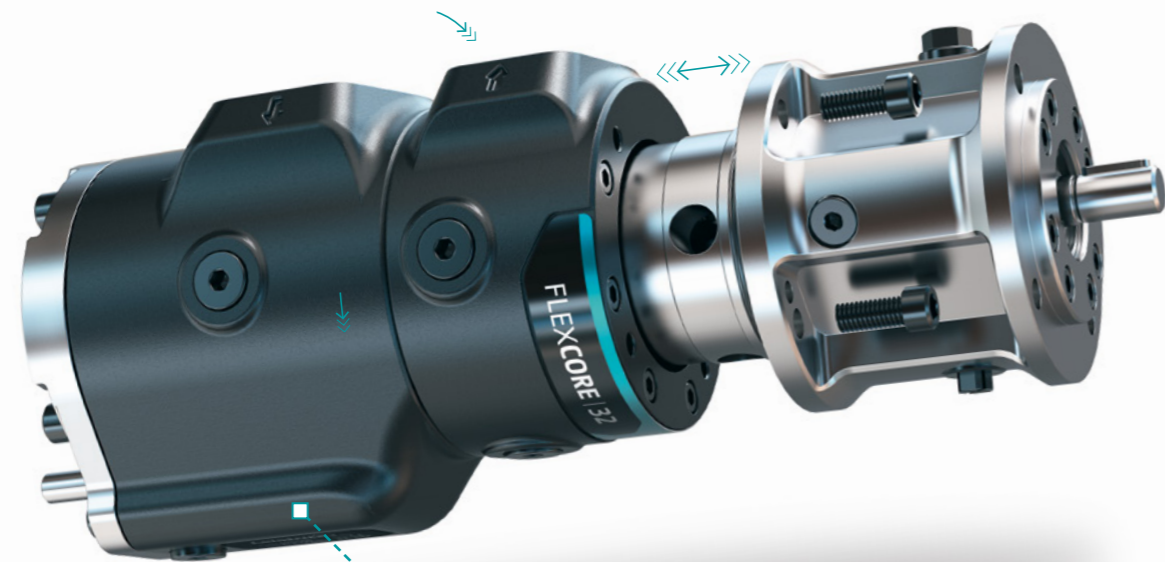

1

## Easy to retrofit

In any installation situation, FLEXCORE is able to replace almost all screw pumps that are customary in the market, even in existing systems.

2

## Maximum operational reliability

Reliable pump protection thanks to the integrated, adjustable safety valve - as standard.

## Standardized design simplifies

### construction and installation

- Ship class approvals DNV/GL and BV (other options available)
- ATEX-compliant
- Available flange connections DIN<sup>4)</sup>, ASME<sup>4)</sup>, or SAE



<sup>4)</sup> Flange for DIN and ASME available from FLEXCORE | 38 CC and bigger. Not available for FLEXCORE | 25 CC and FLEXCORE | 32 CC.

## Ingeniously simple

A single, multifunctional FLEXCORE cast casing replaces all standard casing types. For a wide range of pressure levels, flow directions, and standards. Easily adjustable to the most varied installation situations. Suction and pressure housing turnable to 4 x 90°, with SAE flange connections. As a result, FLEXCORE is able to replace all conventional screw pumps in any installation situation - even in existing systems. For maximum availability, intelligent same-parts and maintenance concepts.



SIDE-SIDE



ROTATION 90°









ROTATION 180°

## FLEXCORE | A wide field of application

For the viscosity requirements of all industries,

e.g. mechanical engineering, chemical, oil, and naval sectors.

## All pumps available from stock

FLEXCORE CC	FLEXCORE   25 CC	FLEXCORE   32 CC	FLEXCORE   38 CC	FLEXCORE   45 CC	FLEXCORE   52 CC	FLEXCORE   60 CC
						
<b>Flow rates</b>	7–50 l/min	15–100 l/min	28–178 l/min	46–295 l/min	75–367 l/min	110–564 l/min
Dimensions ØxI	140 x 343 mm <sup>2)</sup>		150 x 460 mm <sup>2)</sup>		185 x 572 mm <sup>2)</sup>	
Weight	17 kg		31 kg		62 kg	

<sup>2)</sup> Dimensions with SAE flange.

Technical data and illustrations are non-binding with regard to deliveries. Leistriz reserves the right to change, modify or cancel this promotion at any time without notice.

# FLEXCORE SC

The innovation in steel.

The new standard.



## Meets even the highest standards and specifications

- API 614/676 3rd edition<sup>1)</sup>
- Ship class approvals DNV/GL and BV (other options available)
- ATEX-compliant

1

### Axial suction

The FLEXCORE SC also allows axial suction. For example, for vertical installation using a integrated tank plate.

2

### Always fits

Available flange connections DIN, ASME, or SAE



<sup>1)</sup> according to API deviation list

## Ingeniously simple

A single, multifunctional FLEXCORE steel casing replaces all standard casing types. For a wide range of pressure levels, flow directions, and standards. Easily adjustable to the most varied installation situations. Suction and pressure housing turnable to 4 x 90° – also available with axial suction. As a result, FLEXCORE is able to replace all conventional screw pumps - even in existing systems. For maximum availability, intelligent same-parts and maintenance concepts.



SIDE-SIDE



ROTATION 90°



ROTATION 180°









AXIAL SUCTION

## FLEXCORE | A wide field of application

Also available for applications that require API standard (614/676 3<sup>rd</sup> edition<sup>1)</sup>)

All pumps available from stock

FLEXCORE SC	FLEXCORE   25 SC	FLEXCORE   32 SC	FLEXCORE   38 SC	FLEXCORE   45 SC	FLEXCORE   52 SC	FLEXCORE   60 SC
						
<b>Flow rates</b>	7–50 l/min	15–100 l/min	28–178 l/min	46–295 l/min	75–367 l/min	110–564 l/min
Dimensions Ø x l	140 x 365 mm <sup>2)</sup>		190 x 453 mm <sup>2)</sup>		230 x 571 mm <sup>2)</sup>	
Weight	22 kg		51 kg		98 kg	

<sup>2)</sup> Dimensions with SAE flange.

Technical data and illustrations are non-binding with regard to deliveries. Leistritz reserves the right to change, modify or cancel this promotion at any time without notice.

# FLEXCORE | Smart Pump Sensor

Go digital: available from September 2020



1

## Digital early detection

With the “Smart Pump Sensor”, the pumps can be monitored and their data evaluated at any time. E.g. for maintenance based on operating hours, early fault detection.

2

## Easy to integrate

“Smart Pump Sensor” suitable for all pumps of the FLEXCORE series.

## New features and services

- Simultaneous monitoring of multiple pumps
- Early fault detection
- Fault cause analysis
- Optical status indicator
- Maintenance based on operating hours

**Leistritz Pumpen GmbH**  
Markgrafenstrasse 36-39  
90459 Nuremberg  
Germany

For more information  
and orders  
**+49 911 4306-9690**  
**flexcore@leistritz.com**

Scan the code and  
download FLEXCORE  
info package  
(including CAD data)  
**flexcore.leistritz.com**

