

MCV

Vertical multistage pump

MCV/EN (1211) 4.3

Original instructions

Read and understand this manual prior to operating or servicing this product



EC Declaration of conformity

(Directive 2006/42/EC, appendix II-A)

Manufacturer

SPX Flow Technology Assen B.V.
Dr. A.F. Philipsweg 51
9403 AD Assen
The Netherlands

hereby declares that all pumps member of productfamilies CombiBloc, CombiBlocHorti, CombiChem, CombiDirt, CombiFlex(U)(B), CombiPrime H, CombiLine, CombiLineBloc, CombiMag, CombiMagBloc, CombiNorm, CombiPro(M)(V), CombiPrime V, CombiSump, CombiWell, FRE, FRES, FREF, FREM, KGE(L), KGEF, HCR, MCH(W)(S), MCHZ(W)(S), MCV(S), PHA, MDR whether delivered without drive (last position of serial number = B), or delivered as an assembly with drive (last position of serial number = A), are in conformity with the provisions of Directive 2006/42/EC (as altered most recently) and where applicable the following directives and standards:

- EC directive 2006/95/EG, "Electric equipment for use within certain voltage limits"
- standards EN-ISO 12100 part 1 & 2, EN 809

The pumps to which this declaration refers may only be put into operation after they have been installed in the way prescribed by the manufacturer, and, as the case may be, after the complete system of which these pumps form part, has been made to fulfil the requirements of Directive 2006/42/EC (as altered most recently).

Declaration of incorporation

(Directive 2006/42/EC, appendix II-B)

Manufacturer

SPX Flow Technology Assen B.V.
Dr. A.F. Philipsweg 51
9403 AD Assen
The Netherlands

hereby declares that the partly completed pump (Back-Pull-Out unit), member of productfamilies CombiBloc, CombiBlocHorti, CombiChem, CombiDirt, CombiFlex(U)(B), CombiPrime H, CombiLine, CombiLineBloc, CombiMag, CombiMagBloc, CombiNorm, CombiPro(M)(V), CombiPrime V, FRE, FRES, FREF, FREM, KGE(L), KGEF, HCR, PHA, MDR is in conformity with the following standards:

- EN-ISO 12100 parts 1 & 2, EN 809

and that this partly completed pump is meant to be incorporated into the specified pump unit and may only be put into use after the complete machine of which the pump under consideration forms part has been made and declared to comply with that directive.

Assen, January 1st 2011

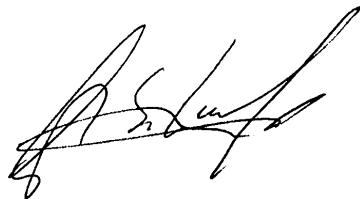

G.A. Schaafsma,
General Manager

Instruction manual

All technical and technological information in this manual as well as possible drawings made available by us remain our property and shall not be used (otherwise than for the operation of this pump), copied, duplicated, made available to or brought to the notice of third parties without our prior written consent.

SPX is a Fortune 500, global multi-industry manufacturing leader. SPX divides its business into four segments and one of these is the SPX Flow Technology segment. SPX Flow Technology Assen B.V. is part of SPX Flow Technology segment.

SPX Flow Technology Assen B.V.
P.O. Box 9
9400 AA Assen
The Netherlands
Tel. +31 (0)592 376767
Fax. +31 (0)592 376760

Copyright © 2008 SPX Corporation

Table of Contents

1	Introduction	9
1.1	Preface	9
1.2	Safety	9
1.3	Guarantee	10
1.4	Inspection of delivered items	10
1.5	Instructions for transport and storage	10
1.5.1	Dimensions and weight	10
1.5.2	Use of pallets	10
1.5.3	Hoisting	11
1.5.4	Storage	11
1.6	Ordering parts	12
2	General	13
2.1	Pump description	13
2.2	Applications	13
2.3	Type code	14
2.4	Serial number	14
2.5	Liquids	15
2.6	Construction	15
2.6.1	Pump section	15
2.6.2	Impellers	15
2.6.3	Bearing construction	15
2.6.4	Shaft seal	16
2.7	Application area	16
2.8	Re-use	16
2.9	Scrapping	16
3	Installation	17
3.1	Safety	17
3.2	Preservation	17
3.3	Environment	17
3.4	Piping	18
3.5	Accessories	18
3.6	Installation	19
3.7	Connection of the electric motor	19
4	Commissioning	21
4.1	Inspection of the pump	21
4.2	Inspection of the motor	21
4.3	Preparing the pump unit for commissioning	21

4.4	Checking the sense of rotation	21
4.5	Start-up	22
4.6	Adjustment of shaft sealing	22
4.6.1	Stuffing box packing	22
4.6.2	Mechanical seal	22
4.7	Pump in operation	22
4.8	Noise	22
5	Maintenance	23
5.1	Daily maintenance	23
5.2	Shaft sealing	23
5.2.1	Stuffing box packing	23
5.2.2	Mechanical seal	23
5.3	Environmental influences	23
5.4	Lubrication of the bearings	24
5.5	Noise	24
5.6	Faults	24
6	Problem solving	25
7	Disassembly and assembly	27
7.1	Special tools	27
7.2	Precautionary measures	27
7.2.1	Switch off the power supply	27
7.2.2	Pipe support	27
7.2.3	Draining the liquid	27
7.3	Dismantling	27
7.4	Disassembly MCV(S)10	28
7.4.1	Disassembly of the lantern piece	28
7.4.2	Disassembling the ball bearings	28
7.4.3	Disassembling the stuffing box packing of MCV	28
7.4.4	Disassembling the mechanical seal of MCVS	29
7.4.5	Disassembly of the pump stage	29
7.5	Assembly MCV(S)10	30
7.5.1	Preparation for assembly	30
7.5.2	Pump assembly	30
7.5.3	Assembling the mechanical seal of MCVS	31
7.5.4	Assembling the stuffing box packing of MCV	31
7.5.5	Assembling the bearing construction	32
7.6	Fitting the electric motor MCV(S)10	32
7.7	Disassembly MCV(S)12,5-14a/b-16-20a/b	33
7.7.1	Disassembly of the lantern piece	33
7.7.2	Disassembly of the ball bearing	33
7.7.3	Disassembly of the stuffing box MCV	33
7.7.4	Disassembly of the mechanical seal MCVS	34
7.7.5	Disassembly of the pump stage	34
7.8	Assembly MCV(S)12,5-14a/b-16-20a/b	35
7.8.1	Preparation for assembly	35
7.8.2	Sub-assembly of covers	35
7.8.3	Pump assembly	36
7.8.4	Mechanical seal assembly MCVS	37
7.8.5	Stuffing box assembly MCV	38
7.8.6	Assembling the bearing construction	38
7.9	Assembling the electric motor	39

8	Dimensions	41
8.1	Dimensions MCV(S) 10	41
8.2	Dimensions MCV(S) 12,5	42
8.3	Dimensions MCV(S) 14a	43
8.4	Dimensions MCV(S) 14b	44
8.5	Dimensions MCV(S) 16	45
8.6	Dimensions MCV(S) 20	46
9	Parts	47
9.1	Ordering parts	47
9.1.1	Order form	47
9.1.2	Recommended spare parts	47
9.2	Designs	47
9.3	MCV(S)10	48
9.3.1	Sectional drawing	48
9.3.2	Parts list MCV 10 x 2-9	49
9.3.3	Parts list MCV 10 x 11-16	50
9.3.4	Parts list MCVS 10 x 2-9	51
9.3.5	Parts list MCVS 10 x 11-16	52
9.4	MCV 12,5 - MCV 14a/b - MCV 16 - MCV 20a/b	53
9.4.1	Sectional drawing	53
9.4.2	Parts list MCV 12,5 x 1-4 - 14a/b x 1-3 - 16 x 1-2	54
9.4.3	Parts list MCV 12,5 x 5-12 - 14a/b x 4-12 - 16 x 3-10	55
9.4.4	Parts list MCV 20a/b x 1	57
9.4.5	Parts list MCV 20a/b x 2-6	58
9.5	MCVS 12,5 - MCVS 14a/b - MCVS 16 - MCVS 20a/b	59
9.5.1	Sectional drawing	59
9.5.2	Parts list MCVS 12,5 x 1-12 - 14a/b x 1-12 - 16 x 1-1	60
9.5.3	Parts list MCVS 20a/b x 1-6	62
9.6	Modifications for boiler feed pumps	63
9.6.1	Sectional drawing	63
9.6.2	Parts list MCV(S) 12,5 - 14a/b - 16 - 20a/b	64
10	Technical data	65
10.1	Maximum speed	65
10.2	Permissible pressure and temperature	66
10.3	Hydraulic performance	67
10.3.1	Performance overview 3000 min-1	67
10.3.2	Performance overview 1500 min-1	68
10.3.3	Performance overview 3600 min-1	69
10.3.4	Performance overview 1800 min-1	70
10.4	Tightening moments for bolts and nuts	71
10.5	Tie rod torque	71
10.6	Post-greasing of ball bearings	71
10.7	Recommended locking liquids	71
10.8	Noise data	72
10.8.1	Pump noise as a function of pump power	72
10.8.2	Noise level of entire pump unit	73
	Index	75
	Order form for spare parts	77

1 Introduction

1.1 Preface

This manual is intended for technicians and maintenance staff and for those who are in charge of ordering spare parts.

This manual contains important and useful information for the proper operation and maintenance of this pump. It also contains important instructions to prevent potential accidents and damage, and to ensure safe and fault-free operation of this pump.

! Read this manual carefully before commissioning the pump, familiarize yourself with the operation of the pump and strictly obey the instructions!

The data published here comply with the most recent information at the time of going to press. However they may be subject to later modifications.

SPX reserves the right to change the construction and design of the products at any time without being obliged to change earlier deliveries accordingly.

1.2 Safety

This manual contains instructions for working safely with the pump. Operators and maintenance staff must be familiar with these instructions.

Installation, operation and maintenance has to be done by qualified and well prepared personnel.

Below is a list of the symbols used for those instructions and their meaning:



Personal danger for the user. Strict and prompt observance of the corresponding instruction is imperative!



Risk of damage or poor operation of the pump. Follow the corresponding instruction to avoid this risk.



Useful instruction or tip for the user.

Items which require extra attention are shown in **bold print**.

This manual has been compiled by SPX with the utmost care. Nevertheless SPX cannot guarantee the completeness of this information and therefore assumes no liability for possible deficiencies in this manual. The buyer/user shall at all times be responsible for testing the information and for taking any additional and/or deviating safety measures. SPX reserves the right to change safety instructions.

1.3 Guarantee

SPX shall not be bound to any guarantee other than the guarantee accepted by SPX. In particular, SPX will not assume any liability for explicit and/or implicit guarantees such as but not limited to the marketability and/or suitability of the products supplied.

The guarantee will be cancelled immediately and legally if:

- Service and/or maintenance is not undertaken in strict accordance with the instructions.
- The pump is not installed and operated in accordance with the instructions.
- Necessary repairs are not undertaken by our personnel or are undertaken without our prior written permission.
- Modifications are made to the products supplied without our prior written permission.
- The spare parts used are not original SPX parts.
- Additives or lubricants used are other than those prescribed.
- The products supplied are not used in accordance with their nature and/or purpose.
- The products supplied have been used amateurishly, carelessly, improperly and/or negligently.
- The products supplied become defective due to external circumstances beyond our control.

All parts which are liable to wear are excluded from guarantee. Furthermore, all deliveries are subject to our "General conditions of delivery and payment", which will be forwarded to you free of charge on request.

1.4 Inspection of delivered items

Check the consignment immediately on arrival for damage and conformity with the advice note. In case of damage and/or missing parts, have a report drawn up by the carrier at once.

1.5 Instructions for transport and storage

1.5.1 Dimensions and weight

A pump or a pump unit is generally too heavy to be moved by hand. Therefore, use the correct transport and lifting equipment. Dimensions and weight of the pump or pump unit are shown on the label on the cover of this manual.

1.5.2 Use of pallets

Usually a pump or pump unit is shipped on a pallet. Leave it on the pallet as long as possible to avoid damages and to facilitate possible internal transport.



When using a forklift always set the forks as far apart as possible and lift the package with both forks to prevent it from toppling over! Avoid jolting the pump when moving it!

1.5.3 Hoisting

When hoisting a pump or complete pump units the straps must be fixed in accordance with figure 1.



When lifting a pump or a complete pump unit always use a proper and sound lifting device, approved to bear the total weight of the load!



Never go underneath a load that is being lifted!



If the electric motor is provided with a lifting eye, this lifting eye is intended only for the purpose of carrying out service activities to the electric motor! The lifting eye is designed to bear the weight of the electric motor only! It is NOT permitted to lift a complete pump unit at the lifting eye of an electric motor!

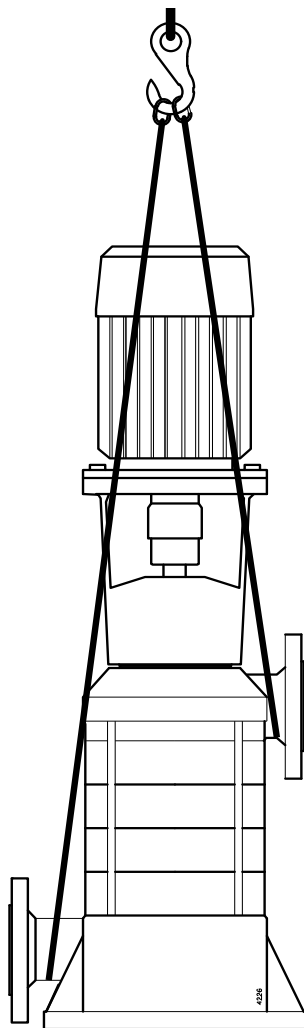

Figure 1: Lifting instructions for pump unit.

1.5.4 Storage

If the pump is not to be used immediately the pump shaft must be turned by hand twice per week.

1.6 **Ordering parts**

This manual contains a survey of the spare parts recommended by SPX as well as the instructions for ordering them. A fax-order form is included in this manual.

You should always state all data stamped on the type plate when ordering parts and in any other correspondence regarding the pump.

➤ *This data is also printed on the label on the front of this manual.*

If you have any questions or require further information with regard to specific subjects, then do not hesitate to contact SPX.

2 General

2.1 Pump description

The MCV is a range of vertical high-pressure stage pumps with closed impellers. The range consists of the following 7 basic types:

- MCV(S) 10
- MCV(S) 12,5
- MCV(S) 14a
- MCV(S) 14b
- MCV(S) 16
- MCV(S) 20a
- MCV(S) 20b

Each basic type can be designed with one or more pressure stages.

The pump is driven by an electric flange motor, which is connected to the lantern piece of the pump. A fitting edge ensures that alignment is not required. The power is transmitted through a flexible coupling.

Due to the modular design of the construction parts there is a high level of interchangeability, even with other types of multistage pumps, such as the MCH or the MCHZ.

2.2 Applications

The pump can be used for the following applications:

- warm and hot water supply systems.
- air-conditioning.
- cooling for land and marine installations.
- water supply for industry, water supply companies, agriculture and horticulture.
- spraying installations.
- washing and condensing installations.
- pressure increasing installations.
- in the process industry, general industry, road and marine construction.

2.3 Type code

Pumps are available in various designs. The main characteristics of the pump are shown in the type code.

Examples: **MCV 12,5 x n - 3,2** or **MCVS 20a x n - 8**

Pump family	
MCV	Multi stage Centrifugal Vertical
Shaft sealing	
	stuffing box packing
S	mechanical seal
Impeller diameter	
10	impeller diameter in cm
12,5	
14	
16	
20	
Impeller width	
	standard impeller
a	narrow impeller
b	wide impeller
Number of stages	
n	number of stages
n,7	n+1 impellers, of which the first has a reduced diameter (70% of full diameter in this example)
Connections	
3,2	diameter suction and pressure connection in cm
5	
6,5	
8	

2.4 Serial number

Serial number of the pump or pump unit are shown on the name plate off the pump and on the label on the cover of this manual.

Example: **01-1000675A**

01	year of manufacture
100067	unique number
5	number of pumps
A	pump with motor
B	pump with free shaft end

2.5 Liquids

In general these pumps are suitable for pumping clean liquids, such as:

- spring water, cold and hot water.
- various cooling liquids.
- caustic soda.
- petrol, kerosene, petroleum.

These liquids must not affect the materials used. For the materials used see the appropriate parts list in chapter 9 "Parts".



We advise against using the pump for an application which differs from that for which the pump was originally supplied, without discussing this with your supplier first! Using a pump in a system or under system conditions (liquid, system pressure, temperature, etc.) for which it has not been designed can create danger for the user!

2.6 Construction

2.6.1 Pump section

The pump section is assembled from an inlet and outlet casing and a number of sections or stage casings with cast vanes. The inlet and outlet casings are fitted with a cast suction and pressure flange, except for the MCV(S) 10 series. For the MCV(S) 10 the inlet and outlet casings are provided with holes with an internal screw thread.

The outlet casing with the pressure connection can be fitted in 4 ways. See the dimensioned sketch for this in chapter 8 "Dimensions". The inlet casing has a cast foot.

The inlet and outlet casings are fitted with connections for pressure gauge, balance pipe, possible barrier liquid and drain.

By using guide blades the radial forces on the rotor can be disregarded over the entire capacity curve.

The stage casings are fitted with exchangeable wear rings. To prevent turbulence and for the benefit of the required NPSH values, there is a suction cover with 2 anti-rotation partitions located in front of the first impeller. For the MCV(S) 10 the anti-rotation partitions are in the inlet casing.

2.6.2 Impellers

All types of MCV(S) pumps are fitted with closed impellers, designed with 2 sealing edges and balance holes. As a result of this the axial forces on the rotor are reduced to a minimum. The remaining forces are taken up by an axially mounted bearing. The impellers are held on the shaft by 2 stainless steel external circlips.

2.6.3 Bearing construction

- Depending on the number of pressure stages, the MCV(S) 10 is fitted with either 1 or 2 single-row angular contact bearings on the pressure side.
- The types MCV(S) 12,5, MCV(S) 14a, MCV(S) 14b, MCV(S) 20a and MCV(S) 20b are fitted with a double-row grease-lubricated angular contact bearing (type 2RS1) on the pressure side.
- The type MCV(S) 16 is fitted with a grease-lubricated deep groove ball bearing on the pressure side.
- The bearing on the pressure side is axially mounted. The bearing is sealed by means of rubber V-rings.
- For all types a slide bearing is fitted in the inlet casing on the suction side and this is lubricated by the pumped liquid.

2.6.4 Shaft seal

The shaft seal for the MCV is available in 2 variants:

1 MCV

Standardized stuffing box packing rings.

Pumps for which the pressure in the stuffing box becomes too high are designed with a balance pipe. The lantern piece is fitted with 2 apertures, so that the stuffing box is easily accessible.

2 MCVS

Mechanical seal with bellows

Cooling and lubrication of this seal is undertaken by circulation of the pumped liquid via a balance pipe.

2.7 Application area

The application area globally looks as follows:

	Maximum value
Capacity	100 m ³ /h
Discharge head	340 m

However, the maximum allowable pressures and temperatures depend strongly on the selected materials and components. Also working conditions may cause differences. For more detailed information see paragraph 10.2 "Permissible pressure and temperature".

2.8 Re-use

The pump may only be used for other applications after prior consultation with SPX or your supplier. Since the lastly pumped medium is not always known, the following instructions should be observed:

- 1 Flush the pump properly
- 2 Make sure the flushing liquid is discharged safely (environment!)



Take adequate precautions and use the appropriate personal protection means (rubber gloves, spectacles)!

2.9 Scrapping

If it has been decided to scrap a pump, the same procedure as for paragraph 2.8 "Re-use" should be followed.

3 Installation

3.1 Safety

- Read this manual carefully prior to installation and commissioning. Non-observance of these instructions can result in serious damage to the pump and this will not be covered under the terms of our guarantee. Follow the instructions given step by step.
- Ensure that the pump can not be started if work has to be undertaken to the pump during installation and the rotating parts are insufficiently guarded.
- Depending on the design the pumps are suitable for liquids with a temperature of up to 120°C. When installing the pump unit to work at 65°C and above the user should ensure that appropriate protection measures and warnings are fitted to prevent contact with the hot pump parts.
- If there is danger of static electricity, the entire pump unit must be earthed.
- If the pumped liquid is harmful to men or the environment, take appropriate measures to drain the pump safely. Possible leakage liquid from the shaft seal should also be discharged safely.

3.2 Preservation

In order to prevent corrosion, the inside of the pump is treated with a preserving agent before leaving the factory. Before commissioning the pump remove any preserving agents and flush the pump thoroughly with hot water.

3.3 Environment

- The foundation must be hard, level and flat.
- The area in which the pump is installed must be sufficiently ventilated. An ambient temperature or air humidity which is too high, or a dusty environment, can have a detrimental effect on the operation of the electric motor.
- There should be sufficient space around the pump unit to operate and if necessary repair it.
- Over the cooling air inlet of the motor there must be a free area of at least ¼ of the electric motor diameter, to ensure unobstructed air supply.
- For models with a stuffing box, check that the gland nuts have not been over-tightened. If necessary slacken the gland nuts and re-tighten them by hand.

3.4 Piping

- The piping to the suction and delivery connections must fit exactly and must not be subject to stress during operation.
- The passage of the suction pipe must be amply dimensioned. This pipe should be as short as possible and run towards the pump in such a way that no air pockets can arise. If this is not possible, a venting facility should be provided at the highest point of the pipe. If the inside diameter of the suction pipe is larger than the suction connection of the pump, an eccentric reducer should be applied to prevent air pockets and whirls. See figure 2.

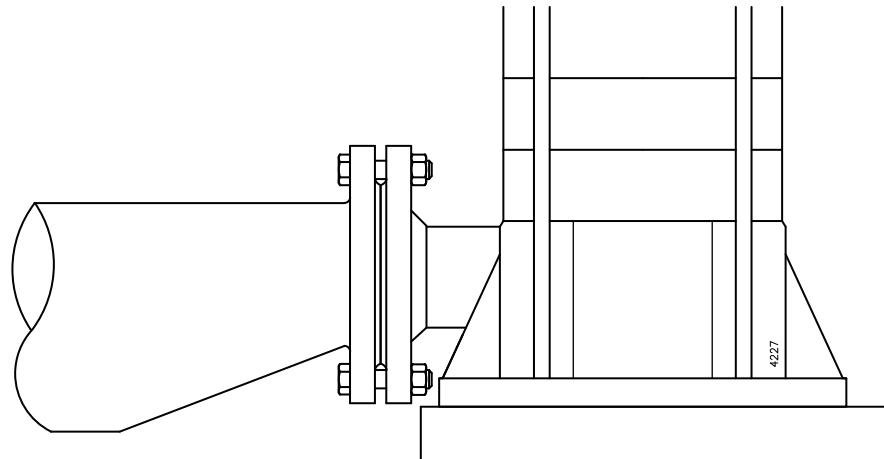

Figure 2: Eccentric reducer to suction flange.

- The maximum allowable system pressure is stated in paragraph 10.2 "Permissible pressure and temperature". If there is a risk that this pressure might be exceeded, for instance because of an excessive inlet pressure, appropriate measures should be taken by mounting a safety valve in the piping.
- Sudden changes in the rate of flow can lead to high pressure impulses in the pump and the piping (water shock). Therefore, do not use quick-acting closing devices, valves etc.

3.5 Accessories

- Fit any parts that may have been supplied separately.
- If the liquid does not flow towards the pump, fit a foot valve at the bottom of the suction pipe. If necessary, combine this foot valve with a suction strainer to prevent impurities from being drawn in.
- When mounting, place temporarily (for the first 24 operating hours) a fine gauze between suction flange and suction pipe to prevent internal pump parts from being damaged by foreign matter. If the risk of damage continues to exist, fit a permanent filter.
- In case the pump is provided with an isolation, special attention has to be paid To temperature limits of shaft seal and bearing.

3.6 Installation

- 1 Position the pump on the foundation. This must be fitted with a provision to fix the foot of the pump (holes for bolt/nut fixing, tapped holes, encapsulated studs).
Fix the pump.
- 2 Fit the gaskets between the flanges and connect the pressure and the suction pipes to the pump.
- 3 If the pump was supplied without an electric motor fit the electric motor now, see paragraph 7.9 "Assembling the electric motor"

3.7 Connection of the electric motor



The electric motor must be connected to the mains by an approved electrician, according to the locally prevailing regulations of the electricity company.

- Refer to the instruction manual belonging to the electric motor.
- If possible, fit a working switch as close as possible to the pump.

4 Commissioning

4.1 Inspection of the pump

- Construction with stuffing box packing: Remove the seal guards (0276). Check whether the nuts have not been over tightened. If necessary, loosen these nuts and tighten them again by hand. Fit the seal guards (0276).
- Check whether the pump shaft turns freely. Do this by turning the shaft end at the coupling a few times by hand.

4.2 Inspection of the motor

- Check whether the fuses have been mounted.

4.3 Preparing the pump unit for commissioning

Proceed as follows, both when the unit is put into operation for the first time and after the pump has been overhauled.

- 1 Fully open the stop valve in the suction pipe. Close the delivery stop valve.
- 2 Fill the pump and the suction pipe with the liquid to be pumped.
- 3 Turn the pump shaft a few times by hand and add more liquid, if necessary.
- 4 For the MCVS model - with the exception of MCVS 10 - vent the seal chamber at the same time using the plug on the seal chamber.

4.4 Checking the sense of rotation



Beware of possible non-screened rotating parts, when checking the sense of rotation!

- 1 The sense of rotation of the pump is indicated by an arrow. Check whether the sense of rotation of the motor corresponds with that of the pump.
- 2 Let the motor run for only a short time and check the sense of rotation.
- 3 If the sense of rotation is **not** correct, alter the sense of rotation. See the instructions in the user manual belonging to the electric motor.
- 4 Fit the guard.

4.5 Start-up

- 1 Start the pump.
- 2 As soon as the pump is under pressure, slowly open the delivery stop valve until the working pressure is attained.



Make sure that when a pump is running, rotating parts are always properly screened off by the guard!

4.6 Adjustment of shaft sealing

4.6.1 Stuffing box packing

After the pump is started, the stuffing box packing will show a certain amount of leakage. Because of the expansion of the packing fibres, this leakage will gradually decrease. Make sure that the stuffing box packing never runs dry. To prevent this, loosen the gland nuts to the extent that the stuffing box packing leaks by drops. As soon as the pump has reached the proper temperature (and leakage is still too much) the gland can be adjusted permanently:

- 1 Tighten both nuts, one after the other, a quarter turn.
- 2 Wait 15 minutes after each adjustment before making the next adjustment.
- 3 Continue in this way until an acceptable leakage by drops has been attained (10/20 cm³/h).



Adjustment of stuffing box packing has to be done with running pump. Take great care not to touch moving parts.

4.6.2 Mechanical seal

- A mechanical seal may never show visible leakage.

4.7 Pump in operation

When the pump is in operation, pay attention to the following:

- The pump should never run dry.
- Never use a stop valve in the suction line to control pump output. The stop valve should always be fully opened during operation.
- Check whether the absolute inlet pressure is sufficient, to prevent vaporization in the pump.
- Check whether the pressure difference between suction and delivery side corresponds with the specifications of the pump's duty point.

4.8 Noise

The noise production of a pump depends to a great extent on the operating conditions. The values stated in paragraph 10.8 "Noise data" are based on normal operation of the pump, driven by an electric motor. In case the pump is driven by a combustion engine, or in case it is used outside the normal operation area, as well as in case of cavitation, the noise level may exceed 85 dB(A). In that case precautions should be taken, like building a noise-barrier around the unit or wearing hearing protection.

5 Maintenance

5.1 Daily maintenance

Regularly check the outlet pressure.



No water should get into the terminal box of the electric motor when the pump room is sprayed clean! Never spray water on hot pump parts! The sudden cooling down may cause them to burst and hot water may flow out!



Flawed maintenance will result in shorter lifespan, possible break down and in any event loss of warranty.

5.2 Shaft sealing

5.2.1 Stuffing box packing

Do not tighten the gland nuts any more after the running-in period and adjustment. If in time the stuffing box packing starts to leak excessively, new packing rings have to be mounted instead of further tightening the nuts!

5.2.2 Mechanical seal

A mechanical seal generally requires no maintenance, however, **it should never be allowed to run dry**. If there are no problems, do not dismantle the mechanical seal. As the seal faces have run in on one another dismantling usually implicates replacement of the mechanical seal. If a mechanical seal shows any leakage it has to be replaced.

5.3 Environmental influences

- Regularly clean the filter in the suction pipe or the suction strainer at the bottom of the suction pipe, as the inlet pressure may become too low if the filter or the suction strainer is fouled.
- If there is a risk that the pumped liquid expands during solidification or freezing, the pump has to be drained and, if necessary, flushed after it has been put out of service.
- If the pump is out of service for a long time, it has to be preserved.
- Check motor for accumulation of dust or dirt, which might influence motor temperature.

5.4 Lubrication of the bearings

- The slide bearing in the bottom of the pump is lubricated by the pumped liquid and requires no maintenance.
- The ball bearings and the ball bearing housing of MCV(S) 10 and MCV(S) 16 are filled with a quantity of grease on delivery which is sufficient for the life of the bearing. The bearing and the bearing housing only need to be cleaned and provided with new grease during overhaul. See paragraph 10.6 "Post-greasing of ball bearings" for recommended greases.
- The ball bearings of MCV(S) 12,5 - 14a - 14b - 20a and 20b are greased for their entire duty life (type 2RS1) and do not require any maintenance.

5.5 Noise

If a pump starts making noise, this may point to certain problems with the pump unit. A crackling noise can indicate cavitation or excessive motor noise can indicate deterioration of the bearings.

5.6 Faults



The pump, of which you want to determine the fault, may be hot or under pressure. Take the appropriate precautions first and protect yourself with the proper safety devices (safety goggles, gloves, protective clothing)!

To determine the source of the malfunctioning of the pump, proceed as follows:

- 1 Switch off the power supply to the pump unit. Lock the working switch with a padlock or remove the fuse.
- 2 Close the stop valves.
- 3 Determine the nature of the fault.
- 4 Try to determine the cause of the fault with chapter 6 "Problem solving" and take the appropriate measures or contact your installer.

6 Problem solving

Faults in a pump installation can have various causes. The fault may not be in the pump, it may also be caused by the pipe system or the operating conditions. Firstly, always check that installation has been executed in accordance with the instructions in this manual and that the operating conditions still correspond with the specifications for which the pump was purchased.

In general, breakdowns in a pump installation are attributable to the following causes:

- Faults with the pump.
- Breakdowns or faults in the pipe system.
- Faults due to incorrect installation or commissioning.
- Faults due to incorrect choice of pump.

A number of the most frequently occurring failures as well as their possible causes are shown in the table below.

Table 1: Most frequently occurring failures.

Most common faults	Possible causes, see Table 2.
Pump delivers no liquid	1 2 3 4 5 6 7 8 9 10 11 13 14 17 19 20 21 29
Pump has insufficient volume flow	1 2 3 4 5 6 7 8 9 10 11 13 14 15 17 19 20 21 28 29
Pump has insufficient head	2 4 5 13 14 17 19 28 29
Pump stops after start up	1 2 3 4 5 6 7 8 9 10 11
Pump has higher power consumption than normal	12 15 16 17 18 22 23 24 25 26 27 32 34 38 39
Pump has lower power consumption than normal	13 14 15 16 17 18 20 21 28 29
The stuffing box packing is leaking excessively	6 7 23 25 26 30 31 32 33 43
Packing rings or mechanical seal have to be replaced to often	6 7 23 25 26 30 32 33 34 36 41
Pump vibrates or is noisy	1 9 10 11 15 18 19 20 22 23 24 25 26 27 29 37 38 39 40
Bearings wear too much or become hot	23 24 25 26 27 37 38 39 40 42
Pump running rough hot or seizes	23 24 25 26 27 34 37 38 39 40 42

Table 2: Possible causes of pump failures.

	Possible causes
1	Pump or suction pipe is not sufficiently filled or de-aerated
2	Gas or air coming from the liquid
3	Air lock in the suction pipe
4	Air leak in the suction pipe
5	The pump takes in air through the stuffing box packing
6	The flush or quench water line to the stuffing box packing is not connected or obstructed
7	The lantern ring in the stuffing box packing has been mounted wrongly
8	The manometric suction head is too high
9	Suction pipe or suction strainer is blocked
10	Insufficient immersion of foot valve or suction pipe during operation of the pump
11	NPSH available too low
12	Speed too high
13	Speed too low
14	Wrong sense of rotation
15	Pump does not operate at the right duty point
16	Liquid density differs from the calculated liquid density
17	Liquid viscosity differs from the calculated liquid viscosity
18	Pump operates when the liquid flow is too low
19	Wrong pump selection
20	Obstruction in impeller or pump casing
21	Obstruction in the piping
22	Wrong installation of the pump unit
23	Pump and motor not well aligned
24	Rotating part running out of true
25	Imbalance in rotating parts (for instance: impeller or coupling)
26	Pump shaft is running out of true
27	Bearings faulty or worn out
28	Casing wear ring faulty or worn out
29	Damaged impeller
30	Shaft sleeve on the spot of the packing rings or seal faces of the mechanical seal are worn out or damaged
31	Worn out or dried out packing rings
32	Not well packed stuffing box packing or bad mounting of the mechanical seal
33	Stuffing box packing type or mechanical seal not suitable for the pumped liquid or operation circumstances
34	Gland or mechanical seal cover has been tightened too much or crookedly
35	No water cooling of packing rings at high temperatures
36	Quenching or flushing liquid to the packing rings or the mechanical seal is polluted
37	Axial retaining of impeller or pump shaft is defective
38	The bearings have been mounted wrongly
39	Too much or too little bearing lubrication
40	Wrong or polluted lubricant
41	Impurities in the liquid get into the stuffing box packing
42	Too high axial force because of worn dorsal blades or excessive inlet pressure
43	Excessive pressure in stuffing box packing space due to too much play in the throttling bush, blocked by-pass or worn dorsal blades

7 Disassembly and assembly

7.1 Special tools

Assembly and disassembly work requires no special tools. However, such tools can make certain jobs easier, for instance replacing the shaft seal. If such is the case it will be indicated in the text.

7.2 Precautionary measures

Before the pump can be repaired it must first be dismantled. The following measures are required for this:

7.2.1 Switch off the power supply

- 1 Switch off the power supply to the pump by placing the pump switch on the control box to the "OFF" position, or if an operating switch is fitted by turning this "OFF".
- 2 Remove the fuses.
- 3 Fit a warning board onto the control box.

7.2.2 Pipe support

If the entire pump has to be removed check that the pipes are supported. If this is not the case, then ensure sufficient support and fixing points for the pipes first.

7.2.3 Draining the liquid



If the liquid being pumped is hot, then allow the pump to cool down further before proceeding. Make sure you do not come into contact with the pumped liquid if this is hot or of an unknown composition!

- 1 Close any relevant stop cocks.
- 2 Drain the pump until no more liquid flows out.

7.3 Dismantling

- 1 Open the cover on the terminal box on the motor.
- 2 Disconnect the mains leads. Mark the wires and the associated terminals. This makes it easier when re-connecting.
- 3 Slacken the foundation bolts and the inlet and outlet pipes and remove the pump from the pipes.

7.4 Disassembly MCV(S)10

If there is no illustration with the instruction, the item numbers used relate to the illustrations in the parts list for this pump, in chapter 9 "Parts".

7.4.1 Disassembly of the lantern piece

- 1 Remove the seal guards (0276).
- 2 Slacken the protective sleeve for the coupling, slide it up and remove the rubber damping strip from between both coupling halves.
- 3 Slacken the bolts and nuts (0690) and remove the electric motor (0680) from the lantern piece (0030).
- 4 Slacken the coupling half (0660) from the pump shaft (0620) and remove the key (0150).
- 5 Remove the upper splash ring (0100) from the pump shaft and slide the lower splash ring down.
- 6 Slacken both bearing covers (0110). Remove the upper bearing cover from the pump shaft, the lower bearing cover will now be free from the shaft.
- 7 Remove the external circlip (0290) and the filling ring (0160) from the pump shaft.
- 8 Using pliers slacken the tie rods (0610) from the lantern piece.
- 9 Lift the lantern piece (0530) vertically from the pump stage. This will draw the bearings from the pump shaft, for 2 up to and including 8 impellers: 1 bearing.
- 10 Remove the bearing cover and the splash ring from the pump shaft.

7.4.2 Disassembling the ball bearings

- 1 Remove the internal circlip (0130) from the bearing housing.
- 2 Push the bearings from the bearing housing using a suitable bush which rests on the outer ring.

7.4.3 Disassembling the stuffing box packing of MCV

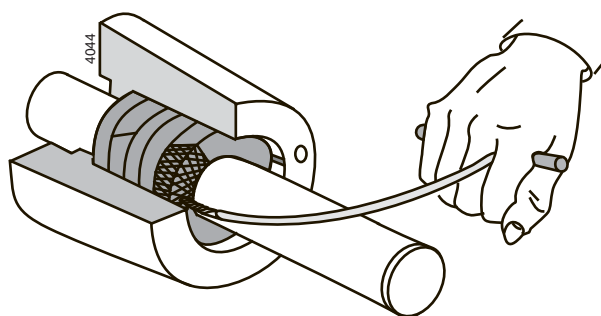

Figure 3: Removing stuffing box packing rings.

Proceed as follows if only the packing rings need to be replaced:

- 1 Remove the seal guards (0276).
- 2 Slacken the gland nuts and remove the gland (0190).
- 3 Remove the packing rings from the stuffing box. Use the special packing puller for this, see figure 3.

If the reason for disassembly was replacement of the gland packing the new packing can now be fitted. See from paragraph 7.5.4 for this.

If the pump is to be further disassembled then removal of the packing rings will be easier if the outlet casing (0020) is removed from the stage set and the shaft end.

7.4.4 Disassembling the mechanical seal of MCVS

Before the mechanical seal can be disassembled the lantern piece will have to be removed. See from paragraph 7.4.1 for this.

- 1 Remove the outlet casing (0020) from the pump shaft and remove the static ring from the mechanical seal (0180).
- 2 Slide the rotating ring for the mechanical seal (0180) off the pump shaft.

If the reason for disassembly was to replace the mechanical seal, the new mechanical seal can now be fitted. See from paragraph 7.5.3 for this.

7.4.5 Disassembly of the pump stage

- 1 Only for MCVS 10: Measure the distance from the set ring to the reduction in diameter on the shaft. Slacken the lock screw (0170) and remove the set ring (0090).
- 2 Remove the upper stage casing (0510) and the upper impeller (0520). Repeat this operation until all stage covers and impellers have been disassembled. If there are 11 or more impellers there is also an external circlip (0560) and a support ring (0570) on the half of the impeller set.
- 3 Remove the keys (0630, 0640 and if there are 16 impellers: 0650) from the pump shaft.
- 4 Remove the pump shaft from the pump casing and remove the lower external circlip (0560) and the support ring (0570). Remove the tie rods from the inlet casing.
- 5 Unscrew the plug (0220) from the inlet casing and, if replacement is necessary, tap the slide bearing (0060) from the inlet casing (0010) using a bar.
- 6 Remove any residual gasket and clean all parts.

7.5 Assembly MCV(S)10

7.5.1 Preparation for assembly

- For the correct torque settings see paragraph 10.5 "Tie rod torque"
- For the correct lubricants and locking agents see paragraph 10.6 "Post-greasing of ball bearings" and paragraph 10.7 "Recommended locking liquids".
- For assembly all relevant parts should always be clean and undamaged.
- Leave bearings and seals for as long as possible in the packing.

7.5.2 Pump assembly

- 1 Put some locking agent (Loctite 641) in the bearing seat and press the slide bearing (0060) into the inlet casing (0010) using a suitable assembly bush.
- 2 Screw a nut (0160) on one end of all tie rods (0610). Tilt the inlet casing and push the tie rods into the inlet casing from below through the apertures.
- 3 Then place the inlet casing with the foot onto the work surface. Fit a gasket (0600) and fit a stage cover (0510).
- 4 Fit a key (0630) to the end of the pump shaft (0620), on the slide bearing side, and slide an impeller (0520) over the bottom end of the shaft, with the impeller opening pointing to the bottom.
- 5 Fit the support ring (0570) and fix the external circlip (0560) to the bottom of the shaft (0620).
- 6 Place the pump shaft in the slide bearing (0060) into the inlet casing (0010).
- 7 Fit a gasket (0600) to the edge and place a stage casing (0510) on the pressure bracket.
- 8 Fit an impeller (0520), the inlet opening of the impeller must be pointing down.



If the impellers have different diameters then those with the largest diameters are fitted in the bottom of the pump

- 9 If required for the impeller set, fit the keys (0640 and 0650). If the pump is designed with 11 impellers or more, the impeller set is divided by an extra support ring (0570) and an external circlip (0560).
- 10 Repeat the steps 7 and 8 until all impellers and stage covers have been fitted.
- 11 If mechanical seals have to be fitted then proceed with paragraph 7.5.3
- 12 Fit the set ring (0090), adjust this to X mm from the underside of the set ring to the reduction in diameter in the pump shaft. Lock the set ring with the lock screw (0170).
- 13 Fit a gasket (0600) and place the outlet casing (0020) on the stage set. Place the outlet opening in the correct position with regard to the suction opening, see dimensional sketch in chapter 8 "Dimensions".



For an MCVS type pump slide the outlet casing vertically over the pump shaft in order not to damage the mechanical seal.

- 14 Fit the internal circlip (0130) and the lower bearing cover (0110) into the lantern piece (0030).
- 15 Place the lantern piece (0030) over the shaft end on the inlet casing. Watch the position of the tie rods.
- 16 Screw the tie rods (0610) into the lantern piece.

7.5.3 Assembling the mechanical seal of MCVS

! **When assembling the mechanical seal pay good attention to the following points:**

- A mechanical seal is a vulnerable component, leave the seal in the original packing until you start with the actual assembly.
- Ensure that the working environment is dust free and that the parts and tools are clean.
- Remove any paint from the pump shaft and the bearing seat.
- **Never place the slide rings on the slide surfaces!**

Proceed as follows:

- 1 Fit the set ring (0090), adjust this to the distance from the bottom of the set ring to reduction in the shaft diameter of the pump shaft measured in step 1 of paragraph 7.4.5. Lock the set ring with the lock screw (0170).
- 2 Fit the rotating part of the seal (0180) with the sliding surface pointing upwards. When fitting this watch out for sharp edges on the groove for the external circlip (0120). Lightly grease the O-ring with acid-free grease.

! **Grease must not be allowed to get on the sliding surfaces!**

- 3 Fit the static ring of the mechanical seal (0180) into the outlet casing (0020), with the sliding surface pointing outward.
- 4 Assemble the outlet casing and the lantern piece, see from step 13 of paragraph 7.5.2.

7.5.4 Assembling the stuffing box packing of MCV

- 1 Grease the packing rings and the stuffing box with graphite grease or silicone grease.
- 2 Bend the packing rings axially open, see figure 4 and fit these around the pump shaft. Ensure that the cuts are always at 90° with regard to each other.
- 3 Press the packing rings well home. Use a suitable gland for this.
- 4 Place some assembly grease on the thread and fit the studs (0200), the gland (0190) and the gland nuts (0210). **Do not tighten the gland nuts to much!**

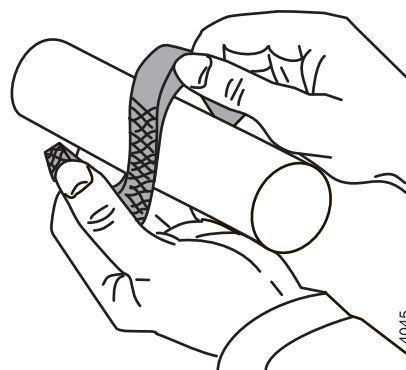

Figure 4: Bending open of a stuffing box packing ring.

7.5.5 Assembling the bearing construction

! **If the bearing does not need to be replaced, the bearing and the bearing housing will still have to be cleaned and provided with new grease.**

- 1 Fit the splash ring (0100) over the pump shaft.
- 2 Grease the bearings on both sides with ball bearing grease. For the correct type of grease see paragraph 10.6 "Post-greasing of ball bearings".
- 3 Fit the bearings (0210) one by one using a suitable assembly bush, which rests on both the inner and outer rings of the bearing. Up to and including 8 impellers there is only one ball bearing.

! **Make sure the bearings are in the correct position: the inner ring of the ball bearing must be fitted with the smallest diameter on the bottom, see figure 5.**

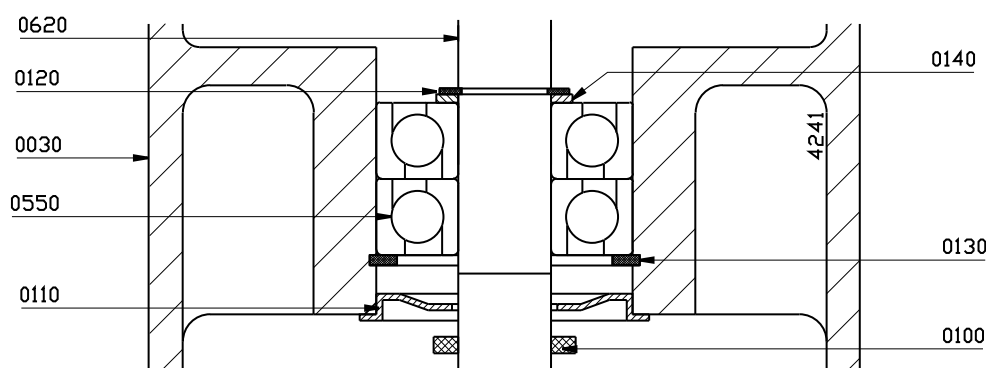

Figure 5: Mounting the ball bearings

- 4 Fit the filling ring (0140) and the external circlip (0120) to the pump shaft.
- 5 Fit the outermost bearing cover (0110) and the splash ring (0100).
- 6 Secure the tie rods in their final position by tilting the pump and tightening the nuts (0160) on the bottom.

7.6 Fitting the electric motor MCV(S)10

Proceed as follows:

- 1 Fit the key (0150) and fix the lower part of the coupling (0660) to the pump shaft.
- 2 Slide the sleeve over the motor shaft and then fix the other part of the coupling (0670) to the motor shaft.
- 3 Place the electric motor on the lantern piece. Make sure that the face of the electric motor fits correctly into the lantern piece. There must be a gap of **3 mm** between both coupling halves. Secure the coupling halves.
- 4 Fit the rubber damping ring between both coupling halves.
- 5 Slide the sleeve over the lower coupling half and secure it.
- 6 Secure the electric motor to the lantern piece using the nuts and bolts (0690). Alignment is not required due to the fitted joints.
- 7 Fit the seal guards (0276).

7.7 Disassembly MCV(S)12,5-14a/b-16-20a/b



Make sure that the power supply to the pump is switched off and that no one can switch the pump on again unintentionally!

If there is no illustration with the instruction, the item numbers used relate to the illustrations in the parts list for this pump, in chapter 9 "Parts".

7.7.1 Disassembly of the lantern piece

- 1 Remove the seal guards (0276).
- 2 Slacken the protective sleeve for the coupling, slide it up and remove the rubber damping strip from between both coupling halves.
- 3 Slacken the bolts (0840) and remove the electric motor from the lantern piece.
- 4 Slacken the coupling half (0690) from the pump shaft (0590) and remove the key (0270).
- 5 Remove the upper V-ring (0360) from the pump shaft and slide the lower rubber V-ring down.
- 6 Slacken both bearing covers (0110). Remove the upper bearing cover from the pump shaft, the lower bearing cover will now be free from the shaft.
- 7 Remove the upper external circlip (0290) and the filling ring (0160) from the pump shaft.
- 8 Lift the lantern piece (0530) vertically from the pump stage. The bearing will now be drawn from the pump shaft.
- 9 Remove the lower external circlip (0290) and the filling ring (0160) from the pump shaft.
- 10 Remove the bearing cover and the rubber V-ring from the pump shaft.

7.7.2 Disassembly of the ball bearing

- 1 Remove both internal circlips (0300) from the bearing housing.
- 2 Only for MCV(S) 14: Remove both filling rings (0120 and 0130) from the bearing housing.
- 3 Using a suitable bush which rests on the outer ring, press the bearing out of the bearing housing.

7.7.3 Disassembly of the stuffing box MCV

Proceed as follows if only the packing rings need to be replaced:

- 1 Remove the seal guards (0276).
- 2 Slacken the gland nuts and remove the gland (0170).
- 3 Remove the packing rings from the stuffing box. Use a special packing puller for this, see figure 3.

If the pump is to be further disassembled then removal of the packing rings will be easier if the outlet casing (0010) is removed from the stage set and the shaft end.

If the reason for disassembly was replacement of the stuffing box packing the new packing can now be fitted. See from paragraph 7.8.5 for this.

7.7.4 Disassembly of the mechanical seal MCVS

Before the mechanical seal can be disassembled the lantern piece will have to be removed. See from paragraph 7.7.1 for this.

- 1 Slacken the suction pipe (0830) at the upper pipe union (0400).
- 2 Remove the shaft seal cover (0030) from the pump shaft and remove the static ring from the mechanical seal.
- 3 Slide the rotating ring of the mechanical seal (0180)(MCVS 20: (0190)) from the pump shaft.

If the reason for disassembly was to replace the mechanical seal, the new mechanical seal can now be fitted. See from paragraph 7.8.4 for this.

7.7.5 Disassembly of the pump stage

- 1 Only for MCVS: Unscrew the pipe union (0400) and remove the balance pipe (0830).
- 2 Only for MCVS: Unscrew the adjustment screw (0190, for MCVS 20: 0210) and remove the set ring (0070).
- 3 Unscrew the nuts (0810) (or 0780) from the tie rods and remove the washers (0755) (MCV(S)20: (0815)).
- 4 Remove the outlet casing (0010) from the stage set. Using a suitable bush press or tap the throttling bush (0060) out of the outlet casing.
- 5 Remove the external circlip (0150) and any throttling sleeve (0620) from the pump shaft.
- 6 Remove the upper stage casing (0500) and the upper impeller (0510). Also remove the key (0790, for MCV(S) 20: 0780) from the shaft. Repeat this operation until all stage covers and impellers have been disassembled.
- 7 Remove the pump shaft from the pump casing and remove the external circlip (0150).
- 8 Remove the suction cover (0520) from the inlet casing (0020).
- 9 Remove any residual gasket and clean all parts.

7.8 Assembly MCV(S)12,5-14a/b-16-20a/b

7.8.1 Preparation for assembly

- For the correct torque settings see paragraph 10.5 "Tie rod torque"
- For the correct lubricants and locking agents see paragraph 10.6 "Post-greasing of ball bearings" and paragraph 10.7 "Recommended locking liquids".
- For assembly all relevant parts should be clean and undamaged. Leave bearings and seals for as long as possible in the packing.
- If the bearing does not need to be replaced, the bearing and the bearing housing will have to be cleaned and provided with new grease.

7.8.2 Sub-assembly of covers

Use a suitable assembly bush for inserting the wear rings. The flat side of the wear rings must be positioned equally with the flat side of the cover, see figure 6.

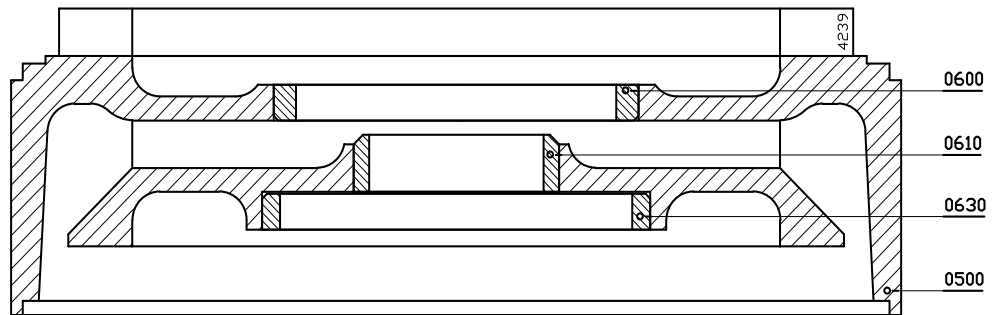

Figure 6: Mounting of wear rings.

- 1 Fit the small wear rings (0610) into the covers (0500).
- 2 Fit a wear ring (0600) into the suction cover (0520).
- 3 Fit the wear rings (0600) and (0630) into the covers (0500).



For the cover which is directly behind the pressure bracket the wear rings (0600) and (0610) are NOT fitted: the throttling bush (0060) is fitted in the edge for the wear ring (0610), which is fitted in the outlet casing (0010). Wear ring (0600) is not fitted, because there is no impeller on that side of the cover.

7.8.3 Pump assembly

- 1 Place some liquid locking agent Loctite 641 in the bearing seat and press the slide bearing (0140) into the inlet casing (0020) using a suitable mounting bush, see figure 7.

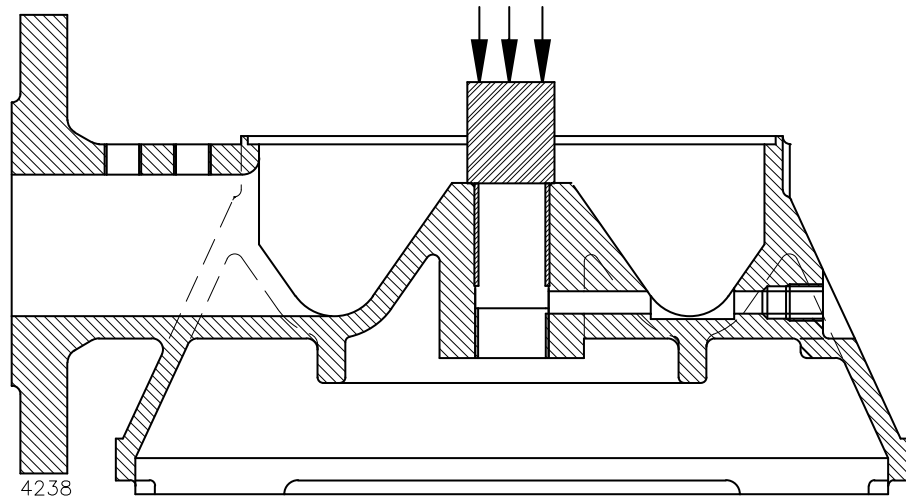

Figure 7: Mounting of slide bearing.

- 2 Screw a nut (0810) on one end of all tie rods (0790 / 0800). Tilt the inlet casing and push the tie rods (or the bolts (0780)) from below through the openings in the inlet casing.
- 3 Then place the inlet casing with the foot onto the work surface. Fit a gasket (0670) to the position of the suction cover (0520).
- 4 Fit a key (0790) into the end of the pump shaft on the slide bearing side and slide an impeller (0510) over the bottom end of the shaft (0590), with the impeller opening pointing to the bottom.
- 5 Fit the external circlip (0150) to the bottom of the shaft (0590).
- 6 Place the pump shaft in the slide bearing (0140) in the inlet casing.
- 7 Fit a gasket (0670) to the edge and place a stage casing (0500) on the outlet casing.
- 8 Fit a key (0790) in the pump shaft and fit an impeller (0510), the inlet opening of the impeller must point down.



If the impellers have different diameters then those with the largest diameters are fitted in the bottom of the pump

- 9 Repeat these steps 7 and 8 until all impellers and stage covers have been fitted.
- 10 Fit the throttling sleeve (0620). The throttling sleeve is not used on all models, see below for a list:

Pump type	Throttling sleeve used on:
MCV(S) 12.5 MCV(S) 14a and 14b	from 8 stages and higher
MCV(S) 16	from 5 stages and higher
MCV(S) 20a and 20b	for all models

- 11 Secure the impeller set by fitting an external circlip (0150) to the pump shaft.

- 12 Fit a throttling bush (0010) into the outlet casing (0060). Use a little locking agent Loctite 641 for this.
- 13 Fit a gasket (0670) and place the outlet casing (0010) on the stage set. Place the outlet flange in the correct position with regard to the suction flange. See dimensions drawing in chapter 8 "Dimensions".
- 14 Fit the washers (0755) (MCV(S)20: (0815)). Tighten the bolts (0780) or the tie rods (0800) (and (0790) for MCV(S)20) using nuts (0780) or (0810) respectively. For the correct torque settings see paragraph 10.5 "Tie rod torque".

7.8.4 Mechanical seal assembly MCVS

! **When assembling the mechanical seal pay good attention to the following points:**

- A mechanical seal is a vulnerable component, leave the seal in the original packing until you start with the actual assembly.
- Ensure that the working environment is dust free and that the parts and tools are clean.
- Remove any paint from the pump shaft and the bearing seat.
- **Never place the slide rings on the slide surfaces!**
- **Never touch the sliding surfaces with ones fingers!**

Proceed as follows:

- 1 Fit the set ring (0070) and lock this with the adjustment screw (0190) (for MCV20: (0210)). For the correct distance see the value **mj** in the table below and figure 8

Pump type	mj
MCVS 12,5 x n	49,5
MCVS 14a and 14b x n	51
MCVS 16 x n	56
MCVS 20a and 20b x n	64,5

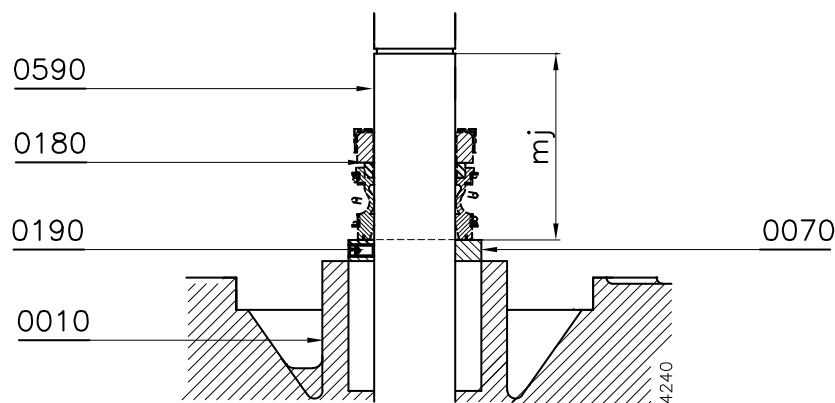

Figure 8: Adjustment of the mechanical seal.

- 2 Check whether there are any sharp edges on the grooves for the external circlips (0290).

- 3 Moisten the shaft with soap-water. Fit the rotating part of the seal by pushing it onto the shaft, meanwhile moving it slightly clockwise. All force must act only on the collar part of the rotating seal part. The sliding surface must face towards the shaft end (drive side).
- 4 Moisten the mechanical seal cover with soap-water. Fit the static ring of the mechanical seal (0180) (MCVS 20: (0190)) into the seal housing of the seal cover (0030), with the sliding surface pointing out.
- 5 Fit the gasket (0170) and fit the cover (0030) into the outlet casing.
In doing this, slide the cover vertically over the pump shaft in order to avoid damaging the seal. Make sure that the connection aperture for any suction pipe is in the correct position.

7.8.5 Stuffing box assembly MCV

- 1 Grease the packing rings and the stuffing box with graphite grease or silicone grease.
- 2 Bend the packing rings axially open, see figure 4, and fit this around the pump shaft. Ensure that the cuts are always at 90° with regard to each other.
- 3 Press the packing rings well home. Use a suitable gland for this.
- 4 Place some assembly grease on the thread and fit the studs (0310), the gland (0170) and the gland nuts (0320). **Do not tighten the gland nuts!**

7.8.6 Assembling the bearing construction

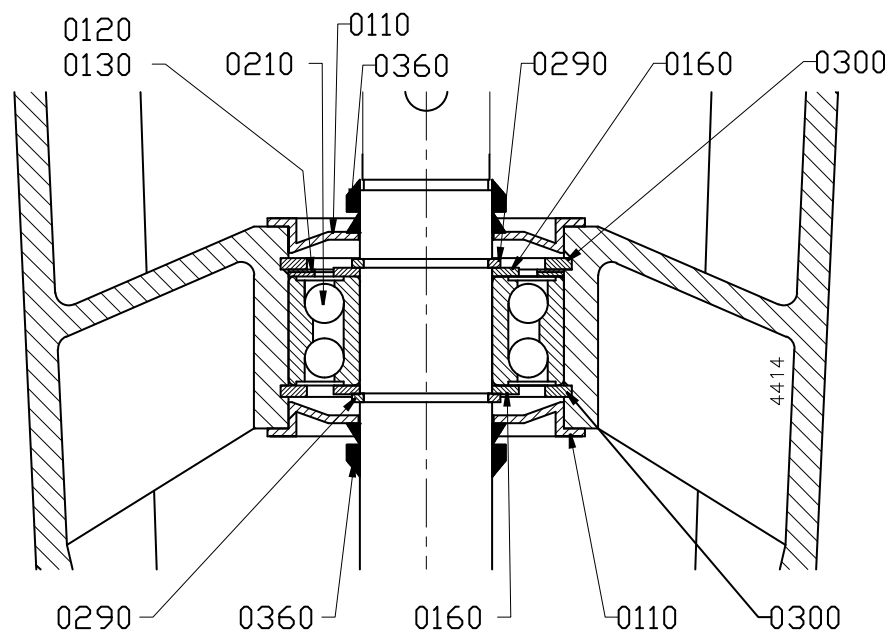

Figure 9: Bearing MCV(S) 12,5 - 14 a/b - 20a/b.

- 1 Fit the lower internal circlip (0300) and the lower bearing cover (0110), see figure 9.
- 2 Fit the rubber V-ring (0360) over the pump shaft (with the narrow opening pointing to the inside of the pump).
- 3 Fix the lantern piece (0530) to the outlet casing using the bolts (0350).
- 4 Fit the external circlip (0290) to the pump shaft in the rear of the 2 grooves and fit the filling ring (0160) over the pump shaft.
- 5 Only for MCV(S)16: Grease the bearing on both sides with ball bearing grease. For the correct type of grease see paragraph 10.6 "Post-greasing of ball bearings".

- 6 Fit the bearing (0210) using a suitable mounting bush which rests on both the inner and outer rings of the bearing.
- 7 Fit the other filling ring (0160) and external circlip (0290) to the pump shaft.
- 8 Only for MCV(S)14a/b: Fit the filling rings (0120) and (0130) to the external ring of the bearing.
- 9 Fix the internal circlip (0300) into the lantern piece.
- 10 Fit the outermost bearing cover (0360) and the rubber V-ring (0110) with the narrow opening pointing to the outside of the pump.
- 11 Fit the balance pipe (0830) if present.

7.9 Assembling the electric motor

Proceed as follows:

- 1 Fit the key (0270) and fix the lower part of the coupling (0690) to the pump shaft.
- 2 Slide the sleeve over the motor shaft and then fix the other part of the coupling (0700) to the motor shaft.
- 3 Place the electric motor on the lantern piece. Make sure that the face of the electric motor fits correctly into the lantern piece. There must be a gap of 3 mm between both coupling halves. Secure the coupling halves.
- 4 Fit the rubber damping ring between both coupling halves.
- 5 Slide the sleeve over the lower coupling half and secure it.
- 6 Secure the electric motor to the lantern piece. Alignment is not required due to the fitted joints.
- 7 Fit the seal guards (0276).

8 Dimensions

8.1 Dimensions MCV(S) 10

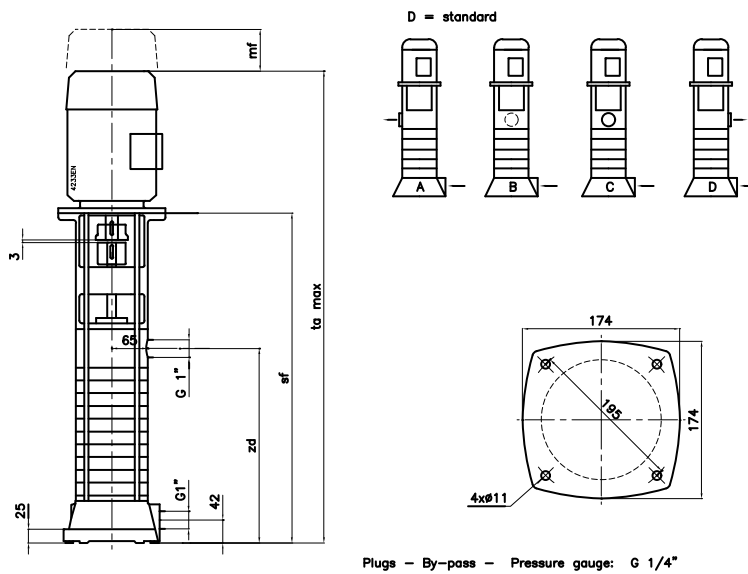

Plugs - By-pass - Pressure gauge: G 1/4"

Figure 10: Dimensions sketch MCV(S) 10.

MCV MCVS	IEC motor	mf	sf	ta _{max}	zd
10 x 2	80 - F 165	70	425	711	180
10 x 3	80 - F 165	70	425	711	180
10 x 4	80 - F 165	70	448	734	203
10 x 4	90S - F 165	80	448	756	203
10 x 5	80 - F 165	70	471	757	226
10 x 5	90S - F 165	80	471	779	226
10 x 5	90L - F 165	80	471	803	226
10 x 6	90S - F 165	80	494	802	249
10 x 6	90L - F 165	80	494	826	249
10 x 8	90L - F 165	80	563	895	318
10 x 8	100L - F 215	90	573	939	318
10 x 9	90L - F 165	80	563	895	318
10 x 9	112M - F 215	90	573	965	318
10 x 11	100L - F 215	90	666	1032	411
10 x 11	112M - F 215	90	666	1058	411
10 x 12	100L - F 215	90	666	1032	411
10 x 12	112M - F 215	90	666	1058	411
10 x 14	112M - F 215	90	712	1104	457
10 x 16	112M - F 215	90	759	1151	504

ta_{max} = Motor length based on DIN 42677, could be different due to applied motor make

8.2 Dimensions MCV(S) 12,5

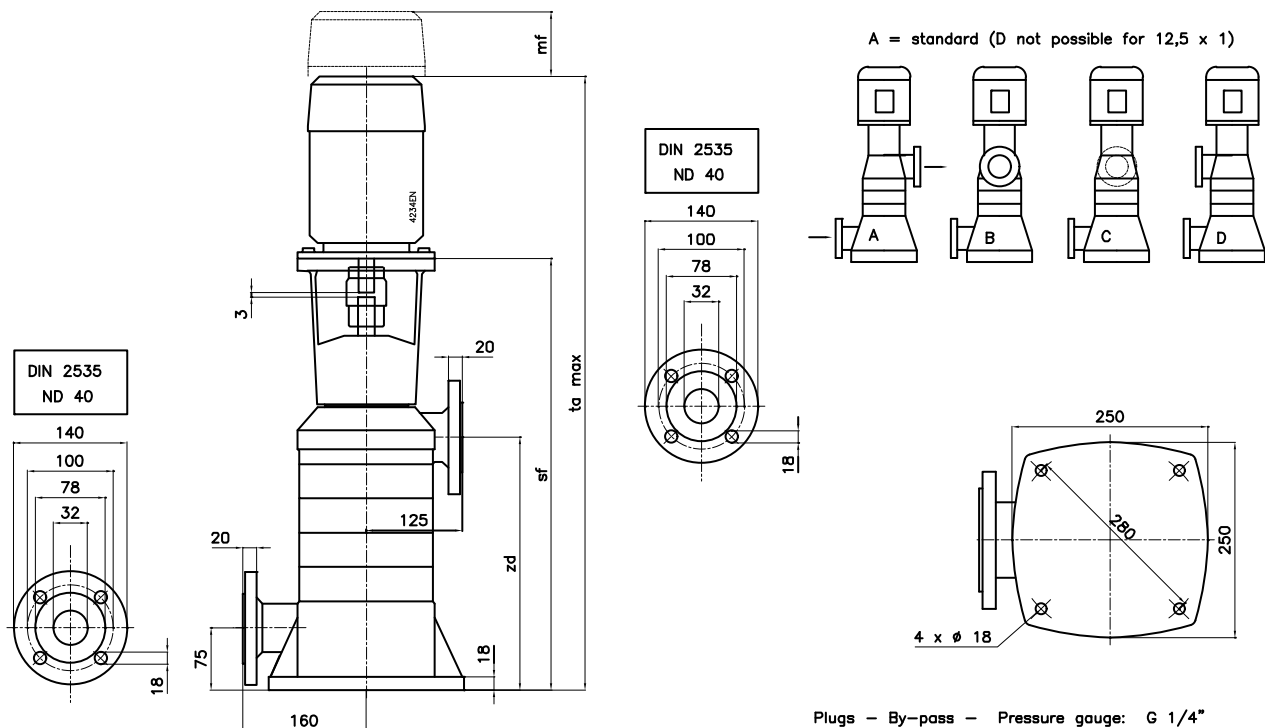

Figure 11: Dimensions sketch MCV(S) 12,5.

IEC motor		63	71	80	90S	90L	100L	112M	132S	160M		
MCV(S)	zd	sf	ta _{max}	sf	ta _{max}	sf	ta _{max}	sf	ta _{max}	sf	ta _{max}	[kg]
12,5 x 1	199	440	660 682	460	746							35
12,5 x 2	244	485	705 727	505	813 837							39
12,5 x 3	289	530	772	550	858 882	560	926					43
12,5 x 4	334	575	817	595	881 927	605	971 997					49
12,5 x 5	379	620	862	640	926	650	1016 1042	670	1120			54
12,5 x 6	424	665	907	685	971	695	1061 1087	715	1165			61
12,5 x 7	459			730	1016 1038	740	1132	760	1210			64
12,5 x 8	514			775	1061 1083					835	1383	68
12,5 x 9	559			820	1106			850	1300	880	1428	72
12,5 x 10	604			865	1151 1173			895	1345	925	1473	76
12,5 x 11	649			910	1196 1218 1242			940	1390			86
12,5 x 12	694			955	1241 1263 1287			985	1435	1115	1663	91
	mf	75		100		125		150		175		

[kg] = max. weight excluding motor

ta_{max} = Motor length based on DIN 42677, could be different due to applied motor make

8.3 Dimensions MCV(S) 14a

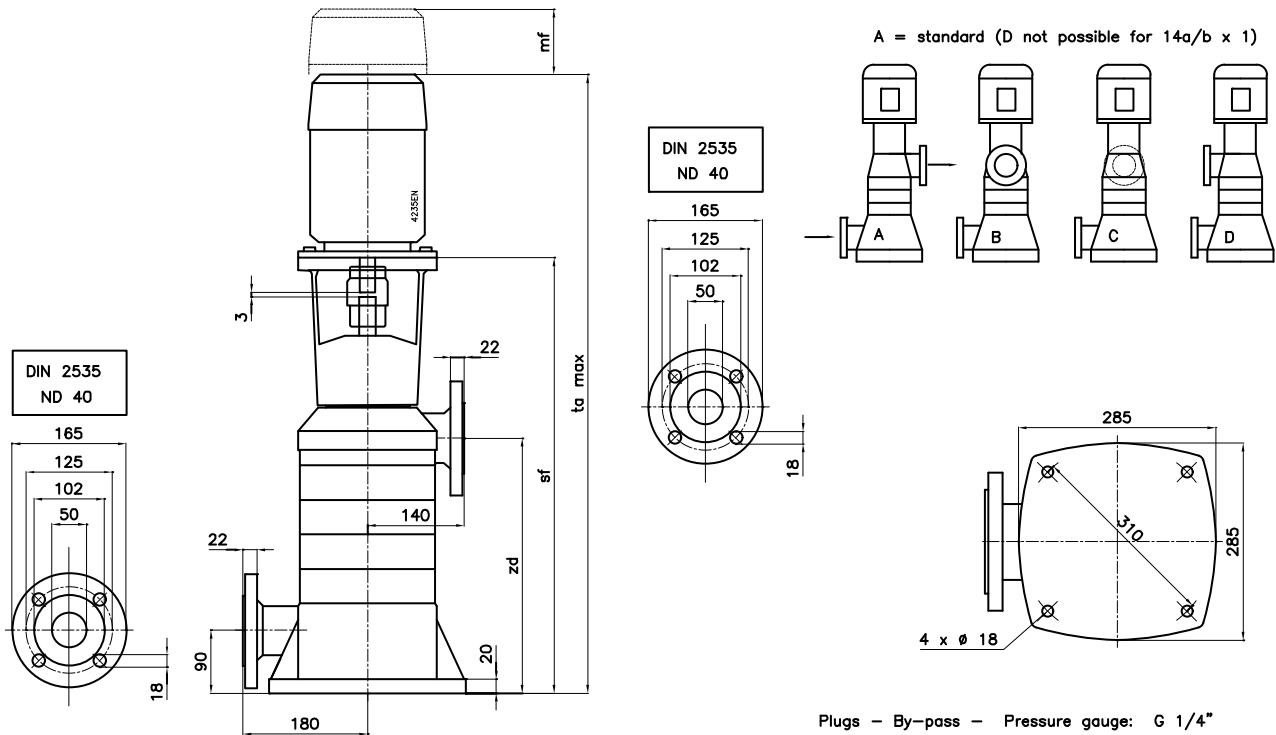

Figure 12: Dimensions sketch MCV(S) 14a.

IEC motor			63	71		80	90S	90L		100L	112M		132S		160M		
MCV(S)	zd	sf	ta _{max}		sf	ta _{max}		sf	ta _{max}		sf	ta _{max}	sf	ta _{max}	sf	ta _{max}	[kg]
14a x 1	219	460	680	702	480		788	812									41
14a x 2	269	510		752	530				540	906	932						50
14a x 3	319				580		888		590		982	610	1060				58
14a x 4	369				630	916	938					660	1110	690	1238		71
14a x 5	419				680	966	988	1012				710	1160	740	1288		77
14a x 6	469				730	1016	1038	1062				760	1210	790	1338		83
14a x 7	519				780	1066	1088	1112	790	1156				840	1388		89
14a x 8	569				830			1162	840	1206				890	1438		95
14a x 9	619				880			1212	890	1256				940	1488		101
14a x 10	669				930			1262	940	1306				990	1538		109
14a x 11	719								990	1356							115
14a x 12	769								1040	1406							121
	mf		75			100			125			150			175		

[kg] = max. weight excluding motor

ta_{max} = Motor length based on DIN 42677, could be different due to applied motor make

8.4 Dimensions MCV(S) 14b

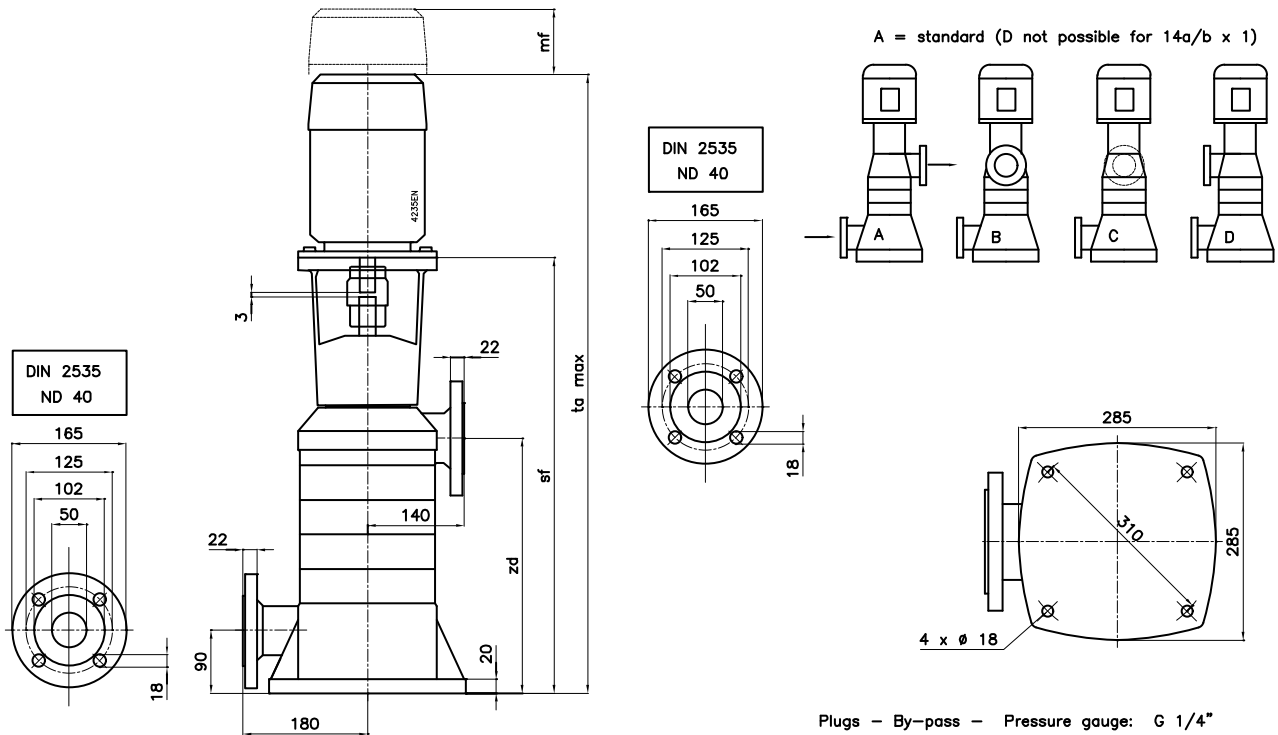

Figure 13: Dimensions sketch MCV(S) 14b.

IEC motor			71		80	90S	90L		100L	112M		132S		160M	160L	180M		
MCV(S)	zd	sf	ta _{max}	sf	ta _{max}			sf	ta _{max}			sf	ta _{max}	sf	ta _{max}			[kg]
14b x 1	219	460	702	480			812	490	856									41
14b x 2	269			530	816			540		932	560	1010						50
14b x 3	319			580	866	888	912				610	1060	640	1188				58
14b x 4	369			630	916	938	962	640			660	1110	690	1238				71
14b x 5	419			680		988	1012	690	1056				740	1288				77
14b x 6	469			730			1062	740	1106				790	1338	1382			83
14b x 7	519			780			1112	790	1156				840	1388		1466		89
14b x 8	569							840	1206				890	1438	1482			95
14b x 9	619							890	1256	1282			940	1488	1532			101
14b x 10	669							940	1306	1332			990		1582	1616		109
14b x 11	719							990	1356	1382								115
14b x 12	769							1040	1406	1432	1060	1510						121
	mf	75			100				125			150		175				

[kg] = max. weight excluding motor

ta_{max} = Motor length based on DIN 42677, could be different due to applied motor make

8.5 Dimensions MCV(S) 16

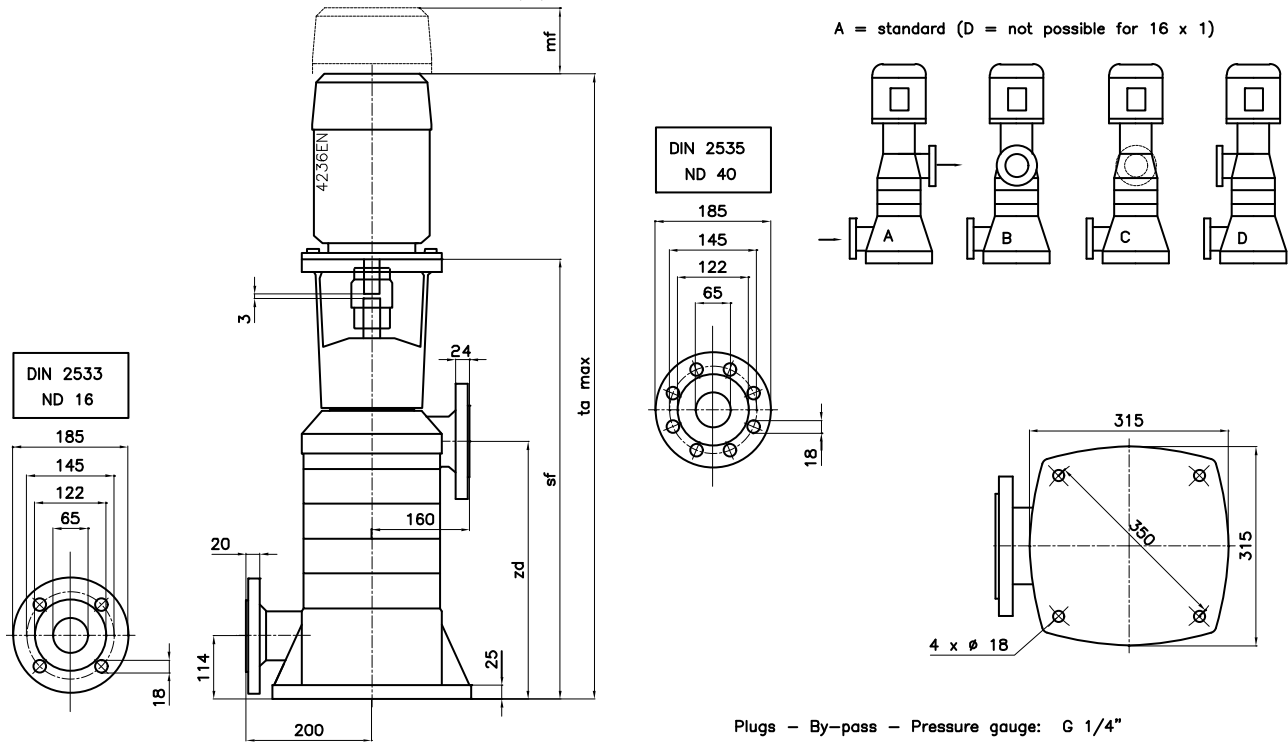

Figure 14: Dimensions sketch MCV(S) 16.

IEC motor			80	90S	90L		100L	112M		132S	132M		160M	160L	180M	200L		
MCV(S)	zd	sf	ta _{max}			sf	ta _{max}			sf	ta _{max}			sf	ta _{max}			[kg]
16 x 1	271	584	870			594				614	1064							65
16 x 2	331	644	930	952	976					674	1124		704	1252				81
16 x 3	391	704		1012	1036	714	1080						764	1312	1356			89
16 x 4	451	764			1096	774	1140						824	1372	1416	1450	1578	97
16 x 5	511					834	1200	1226					884		1476	1510	1638	107
16 x 6	571					894	1260	1286	914	1364			944			1570	1698	118
16 x 7	631					954	1320	1346	974	1424			1004				1758	126
16 x 8	691					1014	1380	1406	1034	1484	1522	1064					1818	134
16 x 9	751					1074		1466	1094	1544	1582							142
16 x 10	811					1134		1526	1154	1604	1642							160
	mf		100			125			150			175			225			

[kg] = max. weight excluding motor

ta_{max} = Motor length based on DIN 42677, could be different due to applied motor make

8.6 Dimensions MCV(S) 20

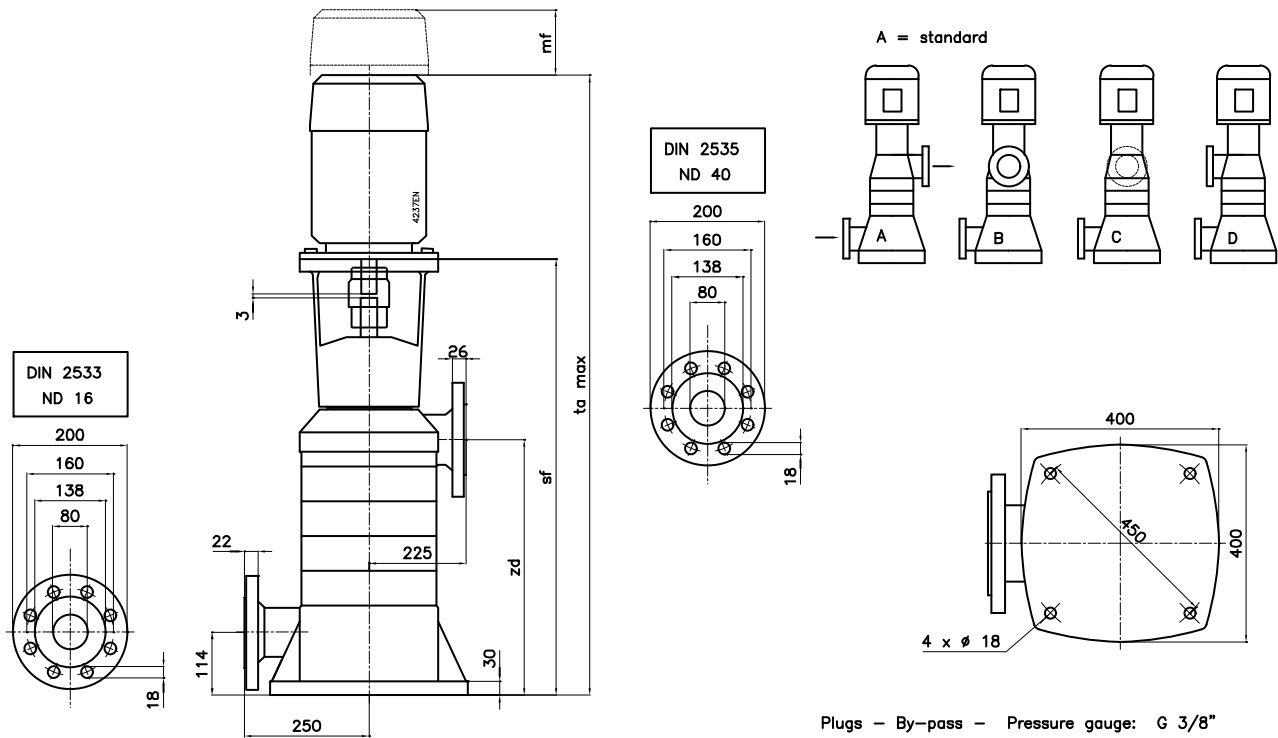

Figure 15: Dimensions sketch MCV(S) 20a/b.

IEC motor		90S		90L		100L		112m		132S		132M		160M		160L		180M		200L		
MCV(S)	zd	sf		ta _{max}		sf		ta _{max}		sf		ta _{max}		sf		ta _{max}				[kg]		
20a x 1	319	638		946 970		648 1014				668 1118				698 1246						110		
20a x 2	394					723 1089 1115								773 1321 1365 1399 1527						135		
20a x 3	469					798 1164 1190				818 1268 1306				848		1474 1602				150		
20a x 4	544					873		1265		893 1343 1381		923						1677	165			
20a x 5	619									968 1418 1456		998 1546						186				
20a x 6	694									1043		1531 1073 1621						210				
20b x 1	319	638		970		648 1014								698 1246 1290						110		
20b x 2	394					723 1089 1115		743 1193								1399 1527				135		
20b x 3	469									818 1268 1306		848 1396						1602	150			
20b x 4	544									893		1381 923 1471						165				
20b x 5	619									968		1456 998 1546 1590						186				
20b x 6	694											1073 1621 1665						210				
	mf	100				125				150				175						225		

[kg] = max. weight excluding motor

ta_{max} = Motor length based on DIN 42677, could be different due to applied motor make

9 Parts

9.1 Ordering parts

9.1.1 Order form

You can use the order form included in this manual for ordering parts.

When ordering parts always quote the following data:

- 1 Your **address**.
- 2 The **quantity, the item number and the description** of the part.
- 3 The **pump number**. The pump number is stated on the label on the cover of this manual and on the type plate of the pump.
- 4 In the event of different electric motor voltage you should state the correct voltage.

9.1.2 Recommended spare parts

Parts marked with a * are recommended spare parts.

9.2 Designs

The following designs are possible in the parts list below, with the exception of the MCV(S)10):

Cast iron:

- Design P: cast iron pump casings, stage casings and impellers
- Design Q: cast iron pump casings and stage casings, bronze impellers.

9.3 MCV(S)10

9.3.1 Sectional drawing

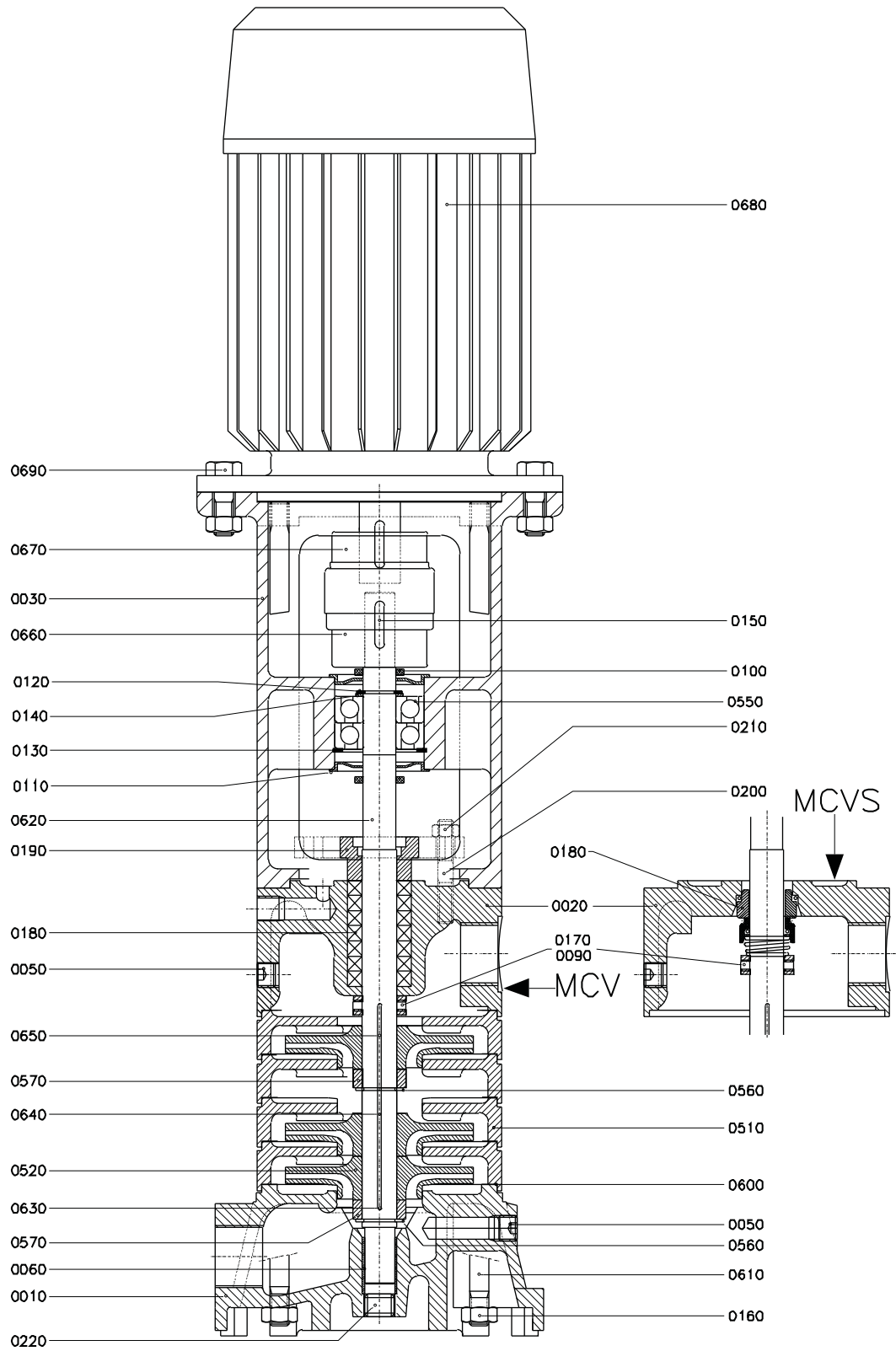

Figure 16: MCV(S) 10.

9.3.2 Parts list MCV 10 x 2-9

Item	Quantity	Description	Material
0010	1	inlet casing	cast iron
0020	1	outlet casing	cast iron
0030	1	lantern piece	cast iron
0050	2	plug	steel
0060*	1	slide bearing	bronze / PTFE
0090	1	set ring	bronze
0100*	2	deflector	rubber
0110	2	bearing cover	steel
0120*	1	outer circlip	steel
0130*	1	inner circlip	steel
0140*	1	filling ring	steel
0150*	1	key	steel
0160	4	nut	steel
0170	2	set screw	alloyed steel
0180*	7	packing ring	--
0190	1	gland	cast iron
0200	2	stud	alloyed steel
0210	2	nut	brass
0220	1	plug	steel
0510	n ¹⁾	stage casing	cast iron
0520*	n	impeller	cast iron
0550*	n ²⁾	ball bearing	--
0560*	1	outer circlip	alloyed steel
0570*	1	distance sleeve	bronze
0600*	n+1 ³⁾	gasket	--
0610*	4	tie rod	alloyed steel
0620*	1	pump shaft	alloyed steel
0630*	1	key	alloyed steel
0660	1	coupling half, pump side	cast iron
0670	1	coupling half, motor side	cast iron
0680	1	motor	--
0690	4	bolt	steel
0691	4	nut	steel

1) for 2 stage and 8 stage design: n+1

2) for 9 stage design: 2

3) for 2 stage and 8 stage design: n+2

9.3.3 Parts list MCV 10 x 11-16

Item	Quantity	Description	Material
0010	1	inlet casing	cast iron
0020	1	outlet casing	cast iron
0030	1	lantern piece	cast iron
0050	2	plug	steel
0060*	1	slide bearing	bronze / PTFE
0090	1	set ring	bronze
0100*	2	deflector	rubber
0110	2	bearing cover	steel
0120*	1	outer circlip	steel
0130*	1	inner circlip	steel
0140*	1	filling ring	steel
0150*	1	key	steel
0160	4	nut	steel
0170	2	set screw	alloyed steel
0180*	7	packing ring	--
0190	1	gland	cast iron
0200	2	stud	alloyed steel
0210	2	nut	brass
0220	1	plug	steel
0510	n+1 ¹⁾	stage casing	cast iron
0520*	n	impeller	noryl
0550*	2	ball bearing	--
0560*	2	outer circlip	alloyed steel
0570*	2	distance sleeve	bronze
0600*	n+2 ²⁾	gasket	--
0610	4	stud	alloyed steel
0620*	1	shaft	alloyed steel
0630*	1	key	alloyed steel
0640*	1	key	alloyed steel
0650*	1 ³⁾	key	alloyed steel
0660	1	coupling half, pump side	cast iron
0670	1	coupling half, motor side	cast iron
0680	1	motor	--
0690	4	bolt with nut	steel

1) for 11 stage design: n+2

2) for 11 stage design: n+3

3) only for 16 stage design

9.3.4 Parts list MCVS 10 x 2-9

Item	Quantity	Description	Material
0010	1	inlet casing	cast iron
0020	1	outlet casing	cast iron
0030	1	lantern piece	cast iron
0050	2	plug	steel
0060*	1	slide bearing	bronze / PTFE
0090	1	set ring	bronze
0100*	2	deflector	rubber
0110	2	bearing cover	steel
0120*	1	outer circlip	steel
0130*	1	inner circlip	steel
0140*	1	filling ring	steel
0150*	1	key	steel
0160	4	nut	steel
0170	2	set screw	alloyed steel
0180*	1	mechanical seal	--
0220	1	plug	steel
0510	n ¹⁾	stage cover	cast iron
0520*	n	impeller	noryl
0550*	1 ²⁾	ball bearing	--
0560*	1	outer circlip	alloyed steel
0570*	1	distance sleeve	bronze
0600*	n+1 ³⁾	gasket	--
0610	4	stud	alloyed steel
0620*	1	shaft	alloyed steel
0630*	1	key	alloyed steel
0660	1	coupling half, pump side	cast iron
0670	1	coupling half, motor side	cast iron
0680	1	motor	--
0690	4	bolt	steel
0691	4	nut	steel

1) for 2 stage and 8 stage design: n+1

2) for 9 stage design: 2

3) for 2 stage and 8 stage design: n+2

9.3.5 Parts list MCVS 10 x 11-16

Item	Quantity	Description	Material
0010	1	inlet casing	cast iron
0020	1	outlet casing	cast iron
0030	1	lantern piece	cast iron
0050	2	plug	steel
0060*	1	slide bearing	bronze / PTFE
0090	1	set ring	bronze
0100*	2	deflector	rubber
0110	2	bearing cover	steel
0120*	1	outer circlip	steel
0130*	1	inner circlip	steel
0140*	1	filling ring	steel
0150*	1	key	steel
0160	4	nut	steel
0170	2	set screw	alloyed steel
0180*	1	mechanical seal	--
0200*	1	O-ring	rubber
0220	1	plug	steel
0510	n+1 ¹⁾	stage casing	cast iron
0520*	n	impeller	noryl
0550*	2	ball bearing	--
0560*	2	outer circlip	alloyed steel
0570*	2	distance sleeve	bronze
0600*	n+2 ²⁾	gasket	--
0610	4	stud	alloyed steel
0620*	1	shaft	alloyed steel
0630*	1	key	alloyed steel
0640*	1	key	alloyed steel
0650*	1 ³⁾	key	alloyed steel
0660	1	coupling half, pump side	cast iron
0670	1	coupling half, motor side	cast iron
0680	1	motor	--
0690	4	bolt with nut	steel

1) for 11 stage design: n+2

2) for 11 stage design: n+3

3) only for 16 stage design

9.4 MCV 12,5 - MCV 14a/b - MCV 16 - MCV 20a/b

9.4.1 Sectional drawing

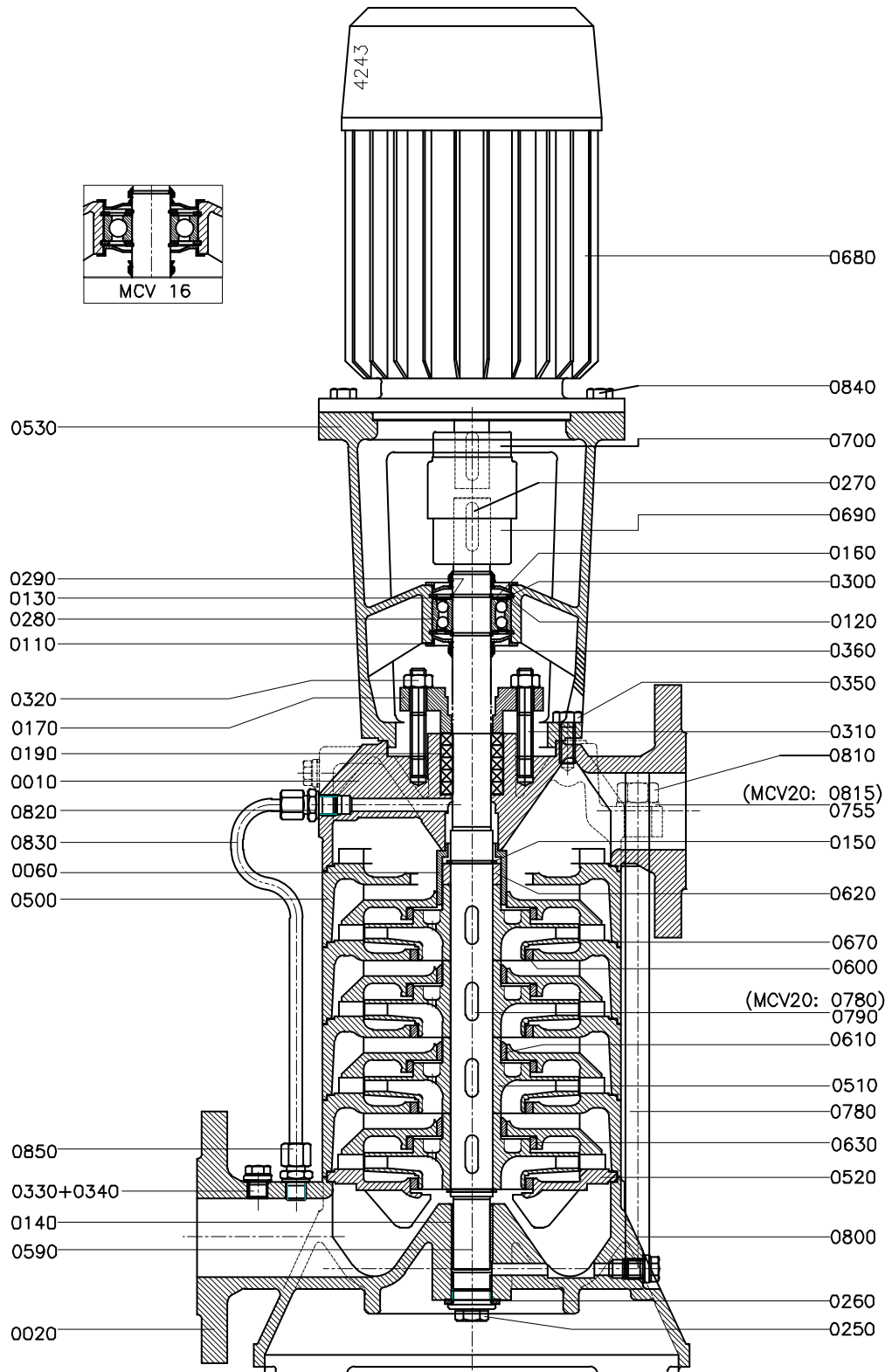

Figure 17: MCV 12,5 - MCV 14a/b - MCV 16 - MCV 20a/b.

9.4.2 Parts list MCV 12,5 x 1-4 - 14a/b x 1-3 - 16 x 1-2

Item	Quantity	Description	Material	
			Design P	Design Q
0010	1	outlet casing	cast iron	
0020	1	inlet casing	cast iron	
0060*	1	throttling bush	bronze	
0110	2	bearing cover	steel	
0120	1 ¹⁾	filling ring	steel	
0130	1 ¹⁾	filling ring	steel	
0140*	1	slide bearing	bronze/PTFE	
0150*	2	outer circlip	alloyed steel	
0160*	2	filling ring	steel	
0170	1	gland	cast iron	
0190*	5	packing ring	--	
0250	1	plug	steel	
0260	1	wear ring	copper	
0270*	1	key	alloyed steel	
0280*	1	ball bearing	--	
0290*	2	outer circlip	steel	
0300*	2	inner circlip	steel	
0310	2	stud	steel	
0320	2	nut	brass	
0330	6	plug	steel	
0340	6	sealing ring	copper	
0350	4	bolt	steel	
0360*	2	V-ring	rubber	
0500	n	stage casing	cast iron	
0510*	n	impeller	cast iron	bronze
0520	1	suction cover	cast iron	
0530	1	lantern piece	cast iron	
0590*	1	shaft	alloyed steel	
0600*	n	wear ring	bronze	
0610*	n-1	wear ring	bronze	
0630*	n	wear ring	bronze	
0670*	n+2	gasket	--	
0680	1	motor	--	
0690	1	coupling half, pump side	cast iron	
0700	1	coupling half, motor side	cast iron	
0755	4	washer	stainless steel	
0760	2	plug	steel	
0770	2	wear ring	copper	
0780	4	bolt with nut	steel	
0790*	n	key	alloyed steel	
0840	4	bolt	steel	

n = number of stages

¹⁾ only for MCV 14a and MCV 14b

9.4.3 Parts list MCV 12,5 x 5-12 - 14a/b x 4-12 - 16 x 3-10

Item	Quantity	Description	Material	
			Design P	Design Q
0010	1	outlet casing	cast iron	
0020	1	inlet casing	cast iron	
0060*	1	throttling bush	bronze	
0110	2	bearing cover	steel	
0120	1 ¹⁾	filling ring	steel	
0130	1 ¹⁾	filling ring	steel	
0140*	1	slide bearing	bronze/PTFE	
0150*	2	outer circlip	alloyed steel	
0160*	2	filling ring	steel	
0170	1	gland	cast iron	
0190*	5	packing ring	--	
0250	1	plug	steel	
0260	1	wear ring	copper	
0270*	1	key	alloyed steel	
0280*	1	ball bearing	--	
0290*	2	outer circlip	steel	
0300*	2	inner circlip	steel	
0310	2	stud	steel	
0320	2	nut	brass	
0330	6	plug	steel	
0340	6	sealing ring	copper	
0350	4	bolt	steel	
0360*	2	V-ring	rubber	
0500	n	stage casing	cast iron	
0510*	n	impeller	cast iron	bronze
0520	1	suction cover	cast iron	
0530	1	lantern piece	cast iron	
0590*	1	shaft	alloyed steel	
0600*	n	wear ring	bronze	
0610*	n-1	wear ring	bronze	
0620*	1 ²⁾	throttling sleeve	alloyed steel	
0630*	n	wear ring	bronze	
0670*	n+2	gasket	--	
0680	1	motor	--	
0690	1	coupling half, pump side	cast iron	
0700	1	coupling half, motor side	cast iron	
0755	4	washer	stainless steel	
0780	4 ³⁾	bolt with nut	steel	
0790*	n	key	alloyed steel	
0800	4 ⁴⁾	stud	alloyed steel	
0810	8 ⁴⁾	nut	steel	

Item	Quantity	Description	Material	
			Design P	Design Q
0820	1	angle pipe union	brass	
0830	1	balance pipe	copper	
0840	4	bolt	steel	
0850	1	pipe union	brass	

n = number of stages

- 1) only for MCV 14a and MCV 14b
- 2) from 8 stages for MCV 12,5 and 14a/b, from 5 stages for MCV 16
- 3) only for MCV 14ax4 and MCV 14bx4
- 4) not for MCV 14ax4 and MCV 14bx4

9.4.4 Parts list MCV 20a/b x 1

Item	Quantity	Description	Material	
			Design P	Design Q
0010	1	outlet casing	cast iron	
0020	1	inlet casing	cast iron	
0060*	1	throttling bush	bronze	
0110	2	bearing cover	steel	
0140*	1	slide bearing	bronze/PTFE	
0150*	2	outer circlip	alloyed steel	
0160*	2	filling ring	steel	
0170	1	gland	cast iron	
0190*	5	packing ring	--	
0200*	1	gasket	--	
0250	1	plug	steel	
0260	1	wear ring	copper	
0270*	1	key	alloyed steel	
0280*	1	ball bearing	--	
0290*	2	outer circlip	steel	
0300*	2	inner circlip	steel	
0310	2	stud	steel	
0320	2	nut	brass	
0330	3	plug	steel	
0340	3	sealing ring	copper	
0350	4	bolt	steel	
0360*	2	V-ring	rubber	
0500	n	stage casing	cast iron	
0510*	n	impeller	cast iron	bronze
0520	1	suction cover	cast iron	
0530	1	lantern piece	cast iron	
0590*	1	shaft	alloyed steel	
0600*	n	wear ring	bronze	
0610*	n-1	wear ring	bronze	
0620*	1	throttling sleeve	alloyed steel	
0630*	n	wear ring	bronze	
0670*	n+2	gasket	--	
0680	1	motor	--	
0690	1	coupling half, pump side	cast iron	
0700	1	coupling half, motor side	cast iron	
0760	2	plug	steel	
0770	2	wear ring	copper	
0780*	n	key	alloyed steel	
0790	4	stud	alloyed steel	
0800	4	stud	alloyed steel	
0810	16	nut	steel	
0815	8	washer	stainless steel	
0830	1	balance pipe	copper	
0840	4	bolt	steel	
0850	1	pipe union	brass	

9.4.5 Parts list MCV 20a/b x 2-6

Item	Quantity	Description	Material	
			Design P	Design Q
0010	1	outlet casing	cast iron	
0020	1	inlet casing	cast iron	
0060*	1	throttling bush	bronze	
0110	2	bearing cover	steel	
0140*	1	slide bearing	bronze/PTFE	
0150*	2	outer circlip	alloyed steel	
0160*	2	filling ring	steel	
0170	1	gland	cast iron	
0190*	5	packing ring	--	
0200*	1	gasket	--	
0250	1	plug	steel	
0260	1	wear ring	copper	
0270*	1	key	alloyed steel	
0280*	1	ball bearing	--	
0290*	2	outer circlip	steel	
0300*	2	inner circlip	steel	
0310	2	stud	steel	
0320	2	nut	brass	
0330	3	plug	steel	
0340	3	sealing ring	copper	
0350	4	bolt	steel	
0360*	2	V-ring	rubber	
0500	n	stage casing	cast iron	
0510*	n	impeller	cast iron	bronze
0520	1	suction cover	cast iron	
0530	1	lantern piece	cast iron	
0590*	1	shaft	alloyed steel	
0600*	n	wear ring	bronze	
0610*	n-1	wear ring	bronze	
0620*	1	throttling sleeve	alloyed steel	
0630*	n	wear ring	bronze	
0670*	n+1	gasket	--	
0680	1	motor	--	
0690	1	coupling half, pump side	cast iron	
0700	1	coupling half, motor side	cast iron	
0760	2	plug	steel	
0770	2	wear ring	copper	
0780*	n	key	alloyed steel	
0790	4	stud	alloyed steel	
0800	4	stud	alloyed steel	
0810	16	nut	steel	
0815	8	washer	stainless steel	
0820	1	angle pipe union	brass	
0830	1	pipe	copper	
0840	4	bolt	steel	
0850	1	pipe union	brass	

9.5 MCVS 12,5 - MCVS 14a/b - MCVS 16 - MCVS 20a/b

9.5.1 Sectional drawing

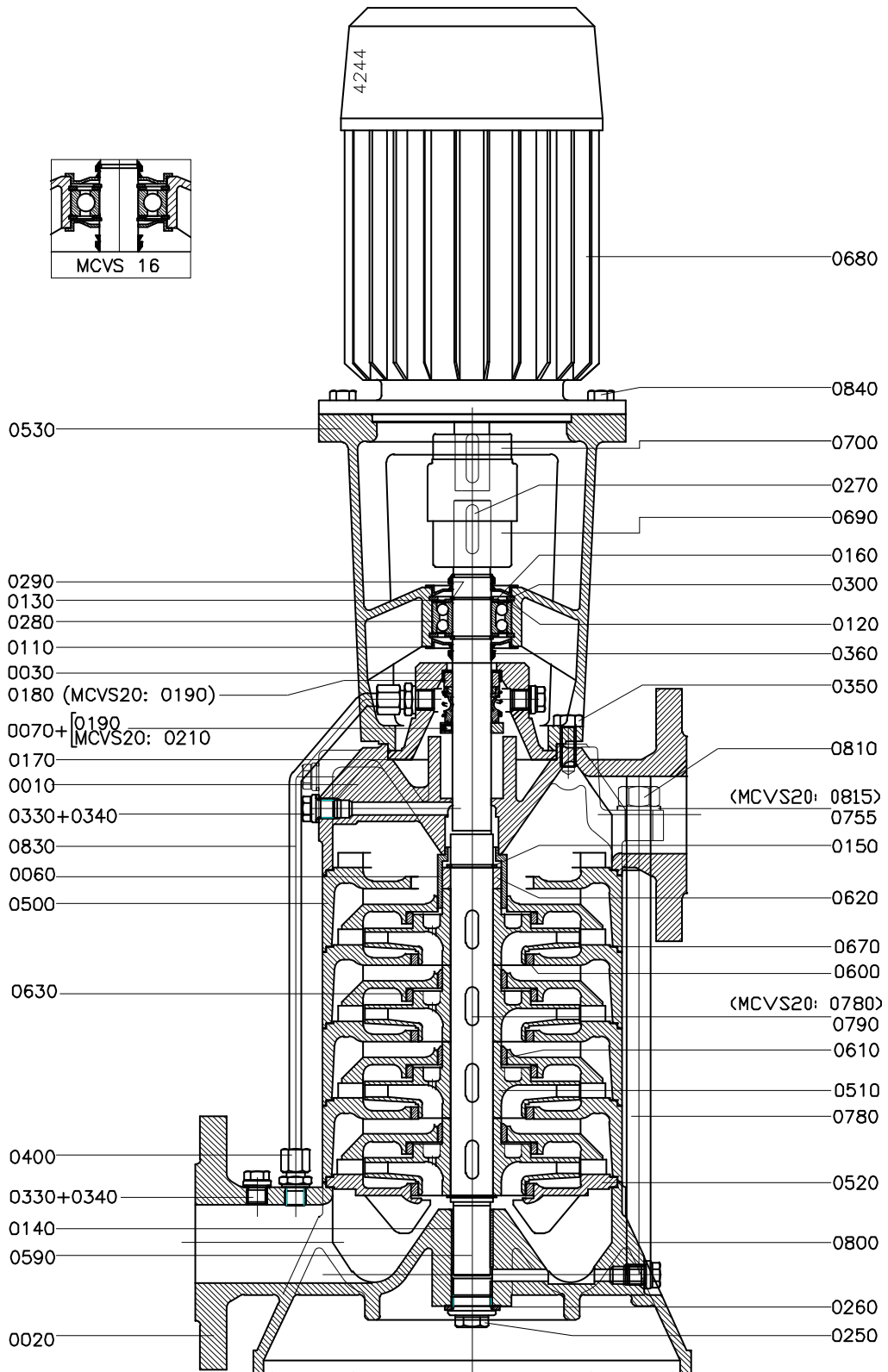

Figure 18: MCVS 12,5 - MCVS 14a/b - MCVS 16 - MCVS 20a/b.

9.5.2 Parts list MCVS 12,5 x 1-12 - 14a/b x 1-12 - 16 x 1-1

Item	Quantity	Description	Material	
			Design P	Design Q
0010	1	outlet casing	cast iron	
0020	1	inlet casing	cast iron	
0030	1	mechanical seal cover	cast iron	
0060*	1	throttling bush	bronze	
0070*	1	set ring	alloyed steel	
0110	2	bearing cover	steel	
0120	1 ¹⁾	filling ring	steel	
0130	1 ¹⁾	filling ring	steel	
0140*	1	slide bearing	bronze/PTFE	
0150*	2	outer circlip	alloyed steel	
0160*	2	filling ring	steel	
0170*	1	gasket	--	
0180*	1	mechanical seal	--	
0190	1	set screw	alloyed steel	
0250	1	plug	steel	
0260	1	wear ring	copper	
0270*	1	key	alloyed steel	
0280*	1	ball bearing	--	
0290*	2	outer circlip	steel	
0300*	2	inner circlip	steel	
0330	7	plug	steel	
0340	7	sealing ring	copper	
0350	4	bolt	steel	
0360*	2	V-ring	rubber	
0400	2	pipe union	brass	
0500	n	stage casing	cast iron	
0510*	n	impeller	cast iron	bronze
0520	1	suction cover	cast iron	
0530	1	lantern piece	cast iron	
0590*	1	shaft	alloyed steel	
0600*	n	wear ring	bronze	
0610*	n-1	wear ring	bronze	
0620*	1 ²⁾	throttling sleeve	alloyed steel	
0630*	n	wear ring	bronze	
0670*	n+2	gasket	--	
0680	1	motor	--	
0690	1	coupling half, pump side	cast iron	
0700	1	coupling half, motor side	cast iron	
0755	4	washer	stainless steel	
0760	2	plug	steel	
0770	2	wear ring	copper	
0780	4 ³⁾	bolt with nut	steel	

Item	Quantity	Description	Material	
			Design P	Design Q
0790*	n	key	alloyed steel	
0800	4 ⁴⁾	stud	alloyed steel	
0810	8 ⁴⁾	nut	steel	
0830	1	balance pipe	copper	
0840	4	bolt	steel	

n = number of stages

1) only for MCV 14a and MCV 14b

2) from 8 stages for MCV 16 and 14a/b, from 5 stages for MCV 12,5

3) up to 4 stages for MCV 16 and 14a/b

4) from 5 stages for MCV 16 and 14a/b, from 3 stages for MCV 12,5

9.5.3 Parts list MCVS 20a/b x 1-6

Item	Quantity	Description	Material	
			Design P	Design Q
0010	1	outlet casing	cast iron	
0020	1	inlet casing	cast iron	
0030	1	mechanical seal cover	cast iron	
0060*	1	throttling bush	bronze	
0070*	1	set ring	alloyed steel	
0110	2	bearing cover	steel	
0140*	1	slide bearing	bronze/PTFE	
0150*	2	outer circlip	alloyed steel	
0160*	2	filling ring	steel	
0170*	1	gasket	--	
0190*	1	mechanical seal	--	
0200*	1	gasket	--	
0210	1	set screw	alloyed steel	
0250	1	plug	steel	
0260	1	wear ring	copper	
0270*	1	key	alloyed steel	
0280*	1	ball bearing	--	
0290*	2	outer circlip	steel	
0300*	2	inner circlip	steel	
0330	7	plug	steel	
0340	7	sealing ring	copper	
0350	4	bolt	steel	
0360*	2	V-ring	rubber	
0410	2	pipe union	brass	
0500	n	stage casing	cast iron	
0510*	n	impeller	cast iron	bronze
0520	1	suction cover	cast iron	
0530	1	lantern piece	cast iron	
0590*	1	shaft	alloyed steel	
0600*	n	wear ring	bronze	
0610*	n-1	wear ring	bronze	
0620*	1	throttling sleeve	alloyed steel	
0630*	n	wear ring	bronze	
0670*	n+1	gasket	--	
0680	1	motor	--	
0690	1	coupling half, pump side	cast iron	
0700	1	coupling half, motor side	cast iron	
0780*	n	key	alloyed steel	
0790	4	stud	alloyed steel	
0800	4	stud	alloyed steel	
0810	16	nut	steel	
0815	8	washer	stainless steel	
0830	1	balance pipe	copper	
0840	4	bolt	steel	

9.6 Modifications for boiler feed pumps

9.6.1 Sectional drawing

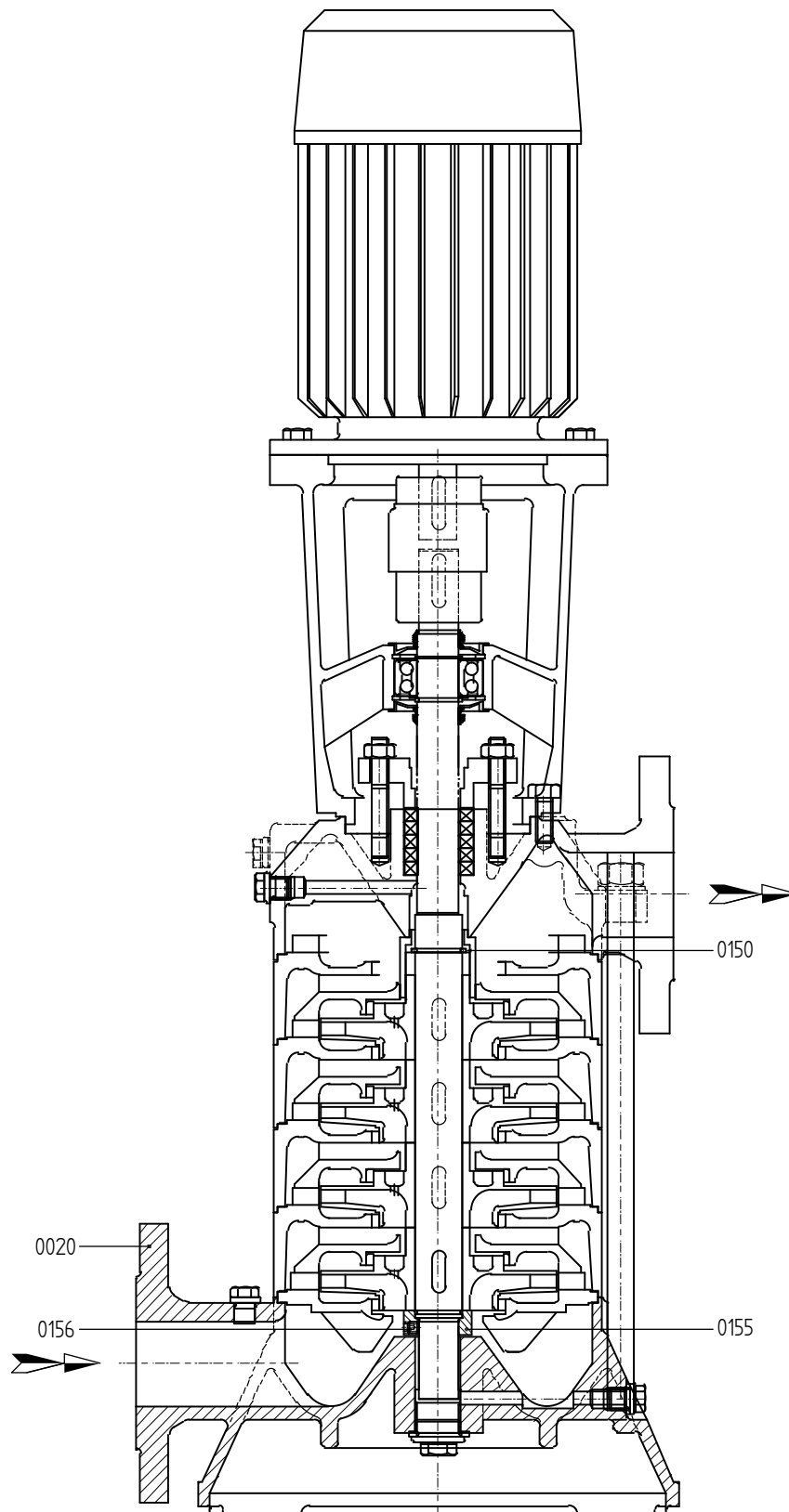

Figure 19: MCV(S) 12,5 - 14a/b - 16 - 20a/b.

9.6.2 Parts list MCV(S) 12,5 - 14a/b - 16 - 20a/b

Item	Quantity	Description	Materials
0020	1	inlet casing	cast iron
0150	1	outer circlip	steel alloy
0155	1	adjusting ring	steel alloy
0156	3	set screw	stainless steel

10 Technical data

10.1 Maximum speed

MCV - MCVS	n_{\max} [min ⁻¹]
10 x 2 - 12	3600
10 x 14 - 16	3000
12,5 x 1 - 10	3600
12,5 x 11 - 12	3000
14a x 1 - 7	3600
14a x 8 - 10	3000
14a x 11 - 12	1800
14b x 1 - 7	3600
14b x 8 - 10	3000
14b x 11 - 12	1800
16 x 1 - 7	3600
16 x 8	3000
16 x 9 - 10	1800
20a x 1 - 3	3600
20a x 4	3000
20a x 5 - 6	1800
20b x 1 - 2	3600
20b x 3	3000
20b x 4 - 6	1800

10.2 Permissible pressure and temperature

MCV(S)	MCV(S) 10	MCV(S) 12,5	MCV(S) 14a	MCV(S) 14b	MCV(S) 16	MCV(S) 20a	MCV(S) 20b
max. capacity [m ³ /h]	8	8	16	26	42	65	100
max. head [m]	180	275	250	255	350	250	160
max. inlet pressure [bar]	5	10					
test pressure [bar]	1,5 x working pressure						
min. test pressure [bar]	15						
max. test pressure [bar]	1,5 x working pressure	50					
max. permitted working pressure*) [bar]	10 (1 - 9 impellers) 25 (11-16 impellers)	40 - (3x inlet pressure)					
temperature range MCV(S) [°C]	-20°C to 120°C						

*) Working pressure is the manometric head for Q=0, increased by the pre-pressure.

10.3 Hydraulic performance

10.3.1 Performance overview 3000 min⁻¹

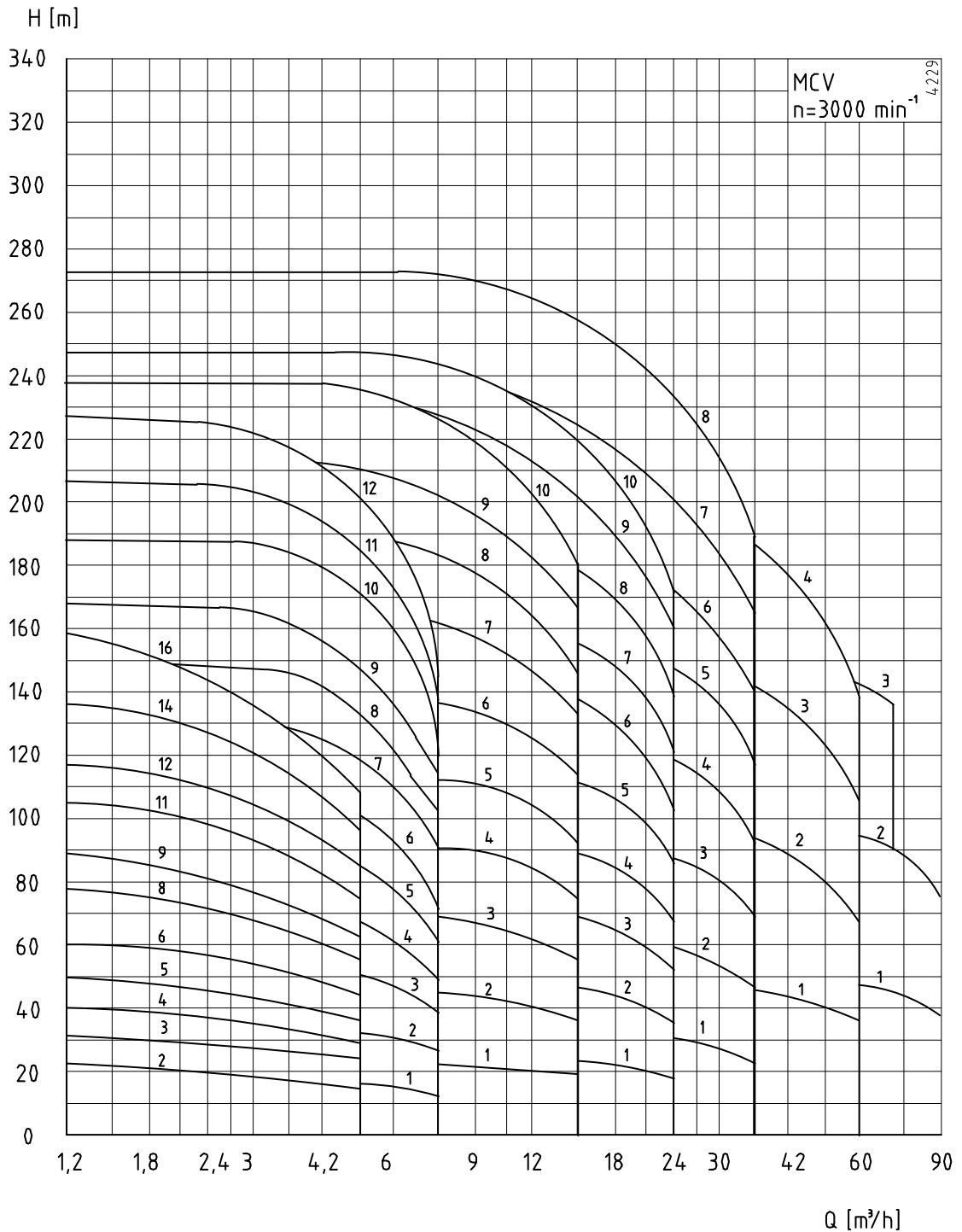

MCV 10	MCV 12,5	MCV 14a	MCV 14b	MCV 16	MCV 20a	MCV 20b
--------	----------	---------	---------	--------	---------	---------

Figure 20: Performance overview 3000 min⁻¹.

10.3.2 Performance overview 1500 min⁻¹

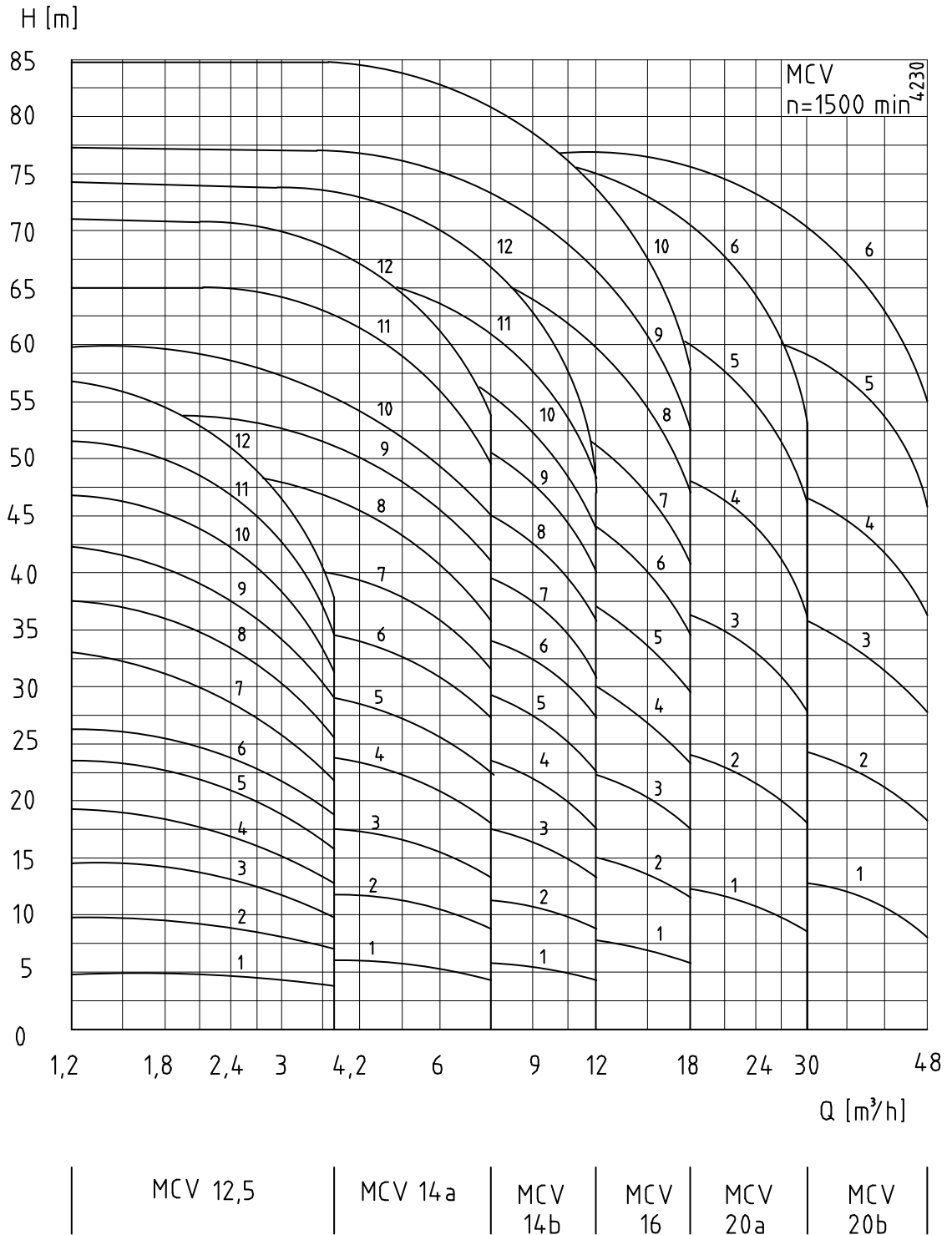

Figure 21: Performance overview 1500 min⁻¹.

10.3.3 Performance overview 3600 min⁻¹

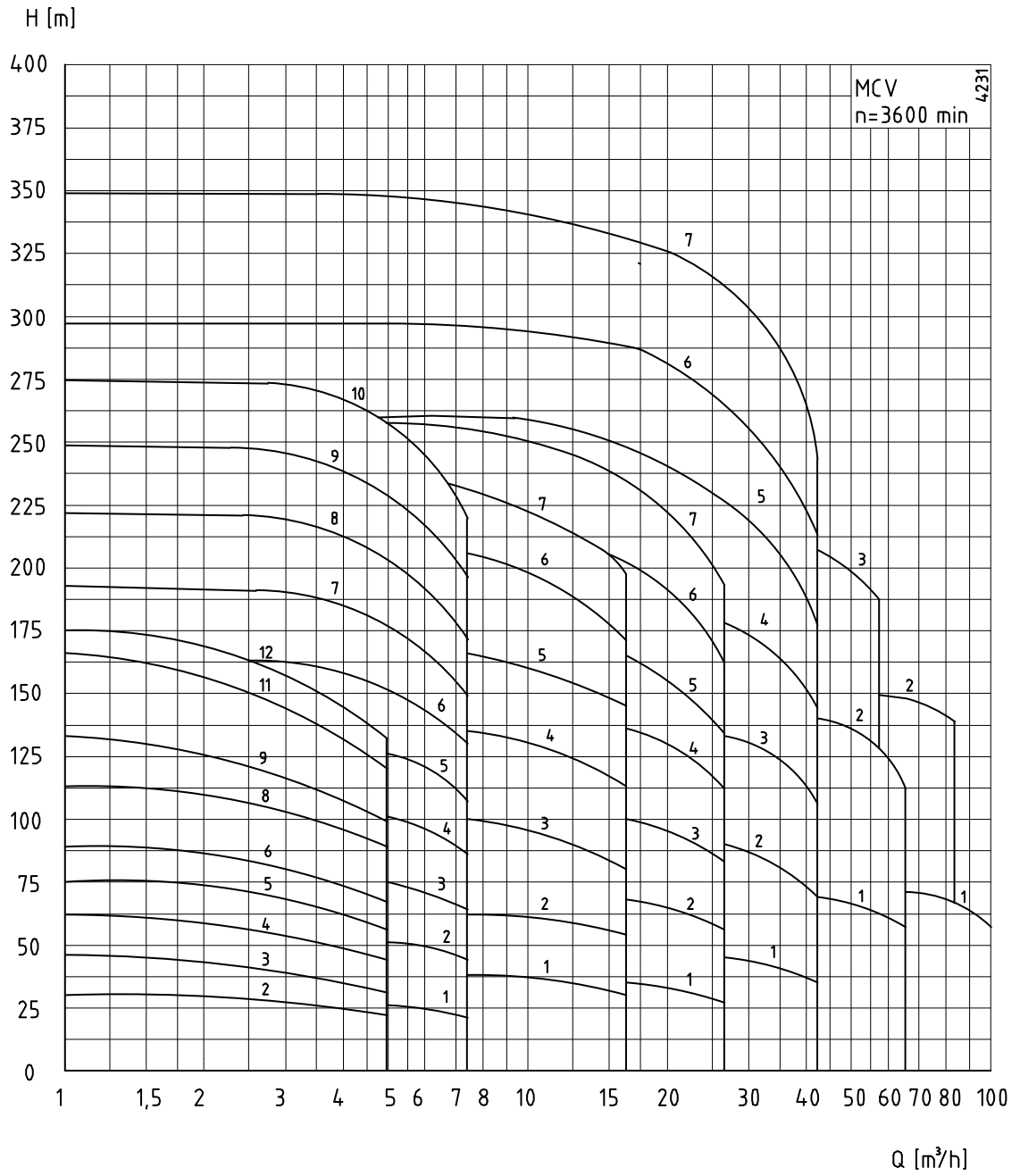

Figure 22: Performance overview 3600 min⁻¹.

10.3.4 Performance overview 1800 min⁻¹

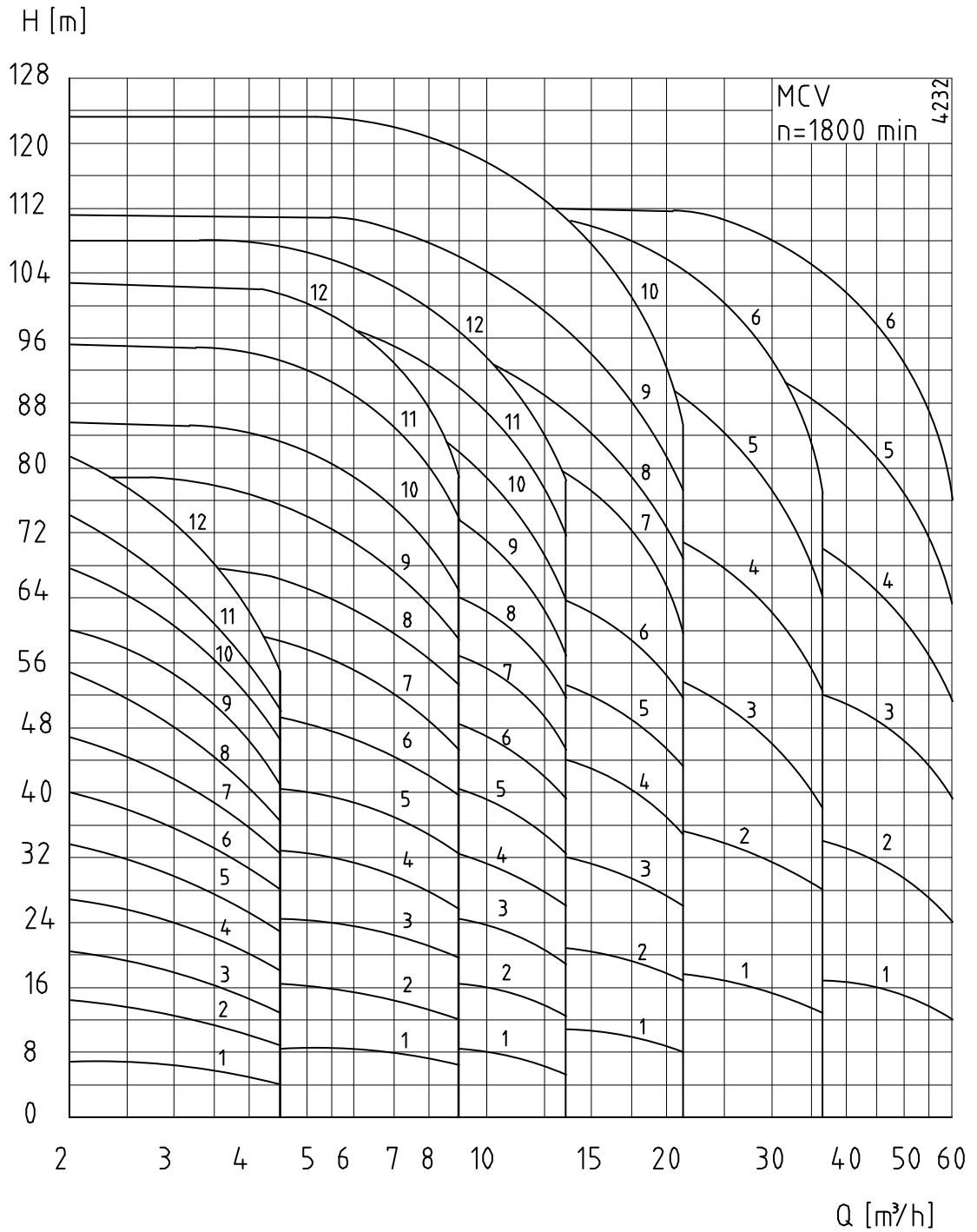

Figure 23: Performance overview 1800 min⁻¹.

10.4 Tightening moments for bolts and nuts

Materials	8.8	A2, A4
Thread	Tightening moment [Nm]	
M6	9	6
M8	20	14
M10	40	25
M12	69	43
M16	168	105

10.5 Tie rod torque

Pump type	Torque [Nm]	Screwthread	Material
MCV(S) 10	40 - 54	M10	40CrMo4
MCV(S) 12,5	89 - 118	M16	
MCV(S) 14a/b	99 - 133	M16	
MCV(S) 16	200 - 267	M20	
MCV(S) 20a/b	137 - 183	M20	

10.6 Post-greasing of ball bearings

See the table below for bearings that require post-greasing and the appropriate type of grease for MCV(S)10 and MCV(S)16.

Table 3: Recommended greases according to NLGI-3 classification.

BP	Energrease LS-EP 3
CHEVRON	MultifaK Premium 3
EXXONMOBIL	Beacon EP 3
	Mobilux EP 3
SHELL	Alvania RL3
SKF	LGMT 3
TOTAL	Total Lical EP 2

10.7 Recommended locking liquids

Description	Locking liquid
slide bearing	Loctite 641
throttling bush	Loctite 641
wear rings	Loctite 641

10.8 Noise data

10.8.1 Pump noise as a function of pump power

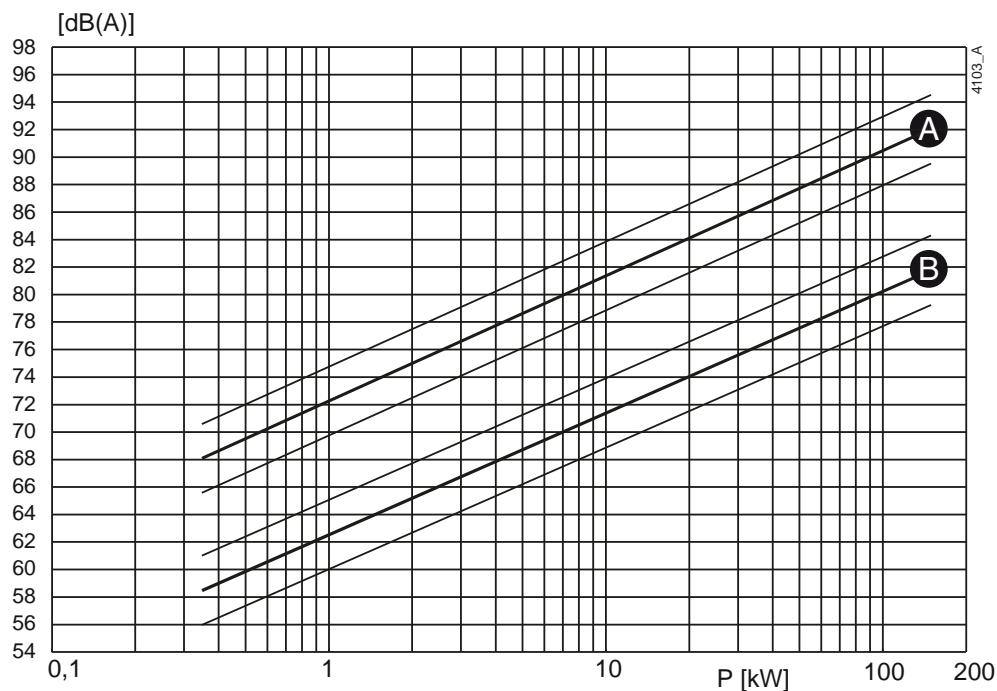

Figure 24: Noise level as function of pump power [kW] at 1450 min^{-1}
 A = sound energy, B = sound pressure.

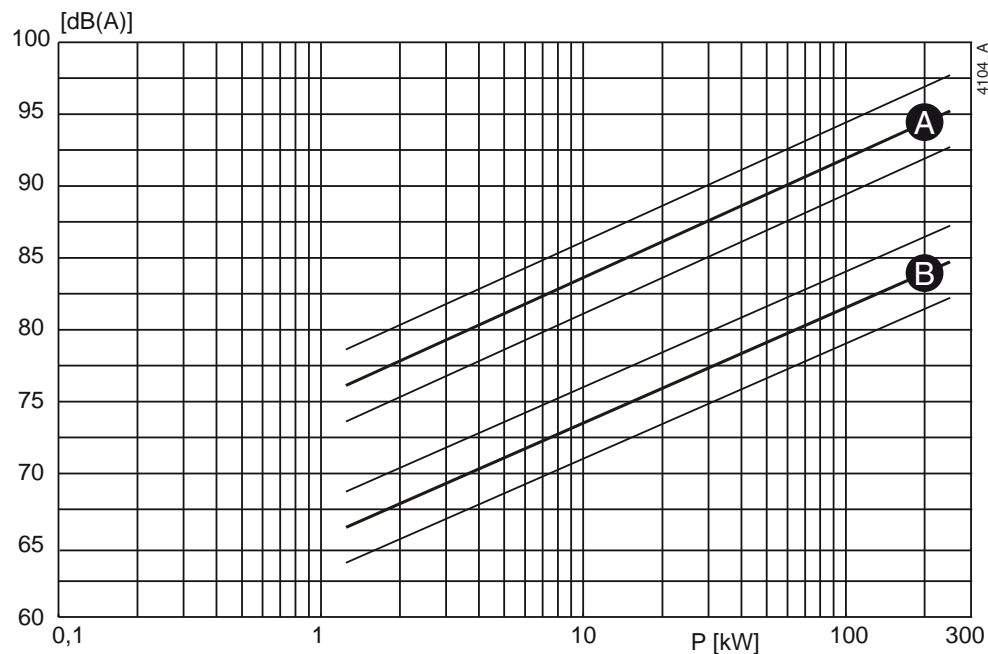

Figure 25: Noise level as function of pump power [kW] at 2900 min^{-1}
 A = sound energy, B = sound pressure.

10.8.2 Noise level of entire pump unit

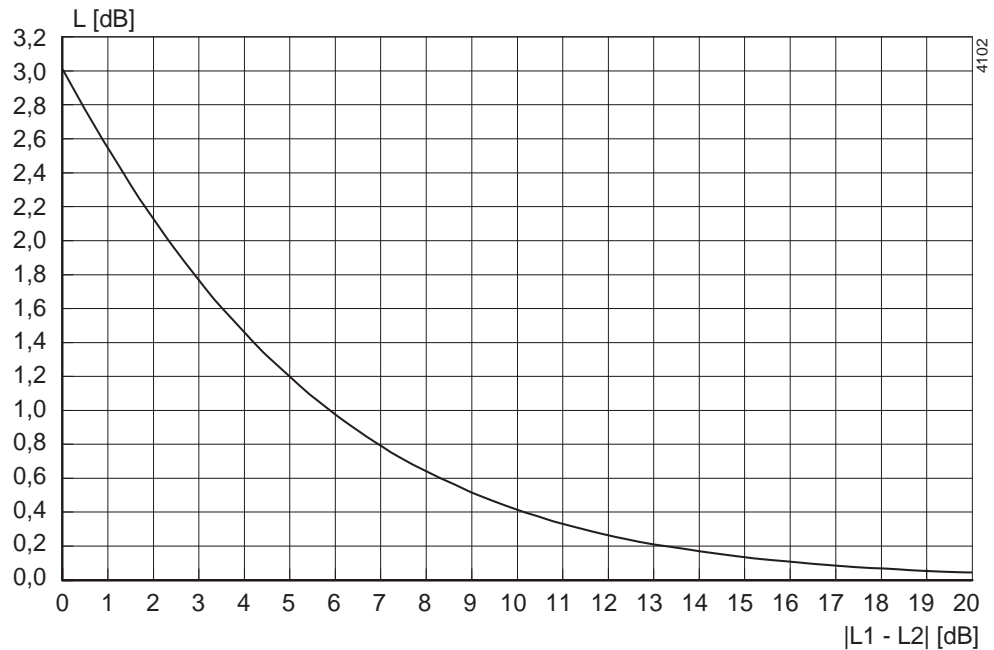

Figure 26: Noise level of entire pump unit.

In order to determine the total noise level of the entire pump unit, the noise level of the motor must be added to that of the pump. This can be easily done by using the graph above.

- 1 Determine the noise level (L1) of the pump, see figure 24 or figure 25.
- 2 Determine the noise level (L2) of the motor, see documentation of the motor.
- 3 Determine the difference between both levels |L1 - L2|.
- 4 Find the differential value on the |L1 - L2|-axis and go up to the curve.
- 5 From the curve go left to the L[dB] -axis and read out the value.
- 6 Add this value to the highest value of both noise levels (L1 or L2).

Example:

- 1 Pump 75 dB; motor 78 dB.
- 2 |75-78| = 3 dB.
- 3 3 dB on the X-axis = 1,75 dB on the Y-axis.
- 4 Highest noise level + 1,75 dB = 78 + 1,75 = 79,75 dB.

Index

A

Accessories18
 Application area16
 Applications13
 Axial forces15

B

balance15
 Balance pipe16
 Ball bearings
 post-greasing71
 Basic type13
 Bearing construction15
 Bearing groups14

C

connecting32
 Construction15

D

Daily maintenance23
 mechanical seal23
 stuffing box packing23

E

Earthing17
 Electric motor32
 connecting39
 connection19
 Environment17
 Environmental influences23

F

Faults24
 Foundation17

G

Guarantee10

H

Hoisting11

I

Impellers15
 Inspection
 motor21
 pump21

L

Lifting eye11
 Liquid
 drain27
 Liquids15
 Lubrication of the bearings24

M

Maintenance staff9
 Mechanical seal22
 Monitoring22

N

Noise22, 24

O

Operational range67

P

Pallets10
 Piping18
 Power supply
 switch off27
 Precautionary measures27
 Pressure66
 Pump
 vent21
 Pump description13
 Pump section15
 Pump unit
 commissioning21

R

Recommended locking liquid71

Re-use16

S

Safety9, 17

 symbols9

Scrapping16

Seal chamber

 vent21

sealing15

Sense of rotation21

Serial number14

Shaft seal16

Special tools27

Start-up22

Static electricity17

Storage 10, 11

Stuffing box packing

 adjustment22

T

Technicians9

Temperature66

Tie rod torque71

Tightening moments

 for bolts and nuts71

Transport10

Type description14

V

Ventilation17

W

Working switch19

Order form for spare parts

FAX Nr.	
ADDRESS	

Your order will only be dealt with if this order form has been correctly completed and signed.

Order date:	
Your order number:	
Pump type:	
Execution:	

Quantity	Item. No.	Part	Article number pump

Delivery address:	Invoicing address:

Ordered by:	Signature:	Telephone:

MCV

Vertical multistage pump



SPX Flow Technology Assen B.V.
Dr. A. F. Philipsweg 51, 9403 AD Assen, THE NETHERLANDS
Phone: + 31 (0) 592 37 67 67 Fax: + 31 (0) 592 37 67 60
E-Mail: johnson-pump.nl@spx.com
www.johnson-pump.com
www.spx.com

For more information about our worldwide locations, approvals, certifications, and local representatives, please visit www.johnson-pump.com.

SPX Corporation reserves the right to incorporate our latest design and material changes without notice or obligation. Design features, materials of construction and dimensional data, as described in this bulletin, are provided for your information only and should not be relied upon unless confirmed in writing.

ISSUED 11/2011 DV-1530
Copyright © 2011 SPX Corporation