

TopGear TG L/RBS-series

INTERNAL GEAR PUMPS

A.0100.201 – IM-TGL/08.04 EN (11/2016)

ORIGINAL INSTRUCTIONS

READ AND UNDERSTAND THIS MANUAL PRIOR TO OPERATING OR SERVICING THIS PRODUCT.



EAC
CE



EC-Declaration of conformity

Machinery Directive 2006/42/EC, Annex IIA

Manufacturer

SPX Flow Technology Belgium NV
Evenbroekveld 2-6
BE-9420 Erpe-Mere
Belgium

Herewith we declare that

TopGear L-range Gear Pumps RBS-series Gear Pumps

are in conformity with the relevant provisions of the Machinery Directive
2006/42/EC, Annex I.

Erpe-Mere, 1 April 2014

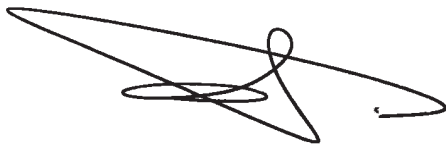
A handwritten signature in black ink, consisting of several loops and a long horizontal stroke, positioned above the name Gerard Santema.

Gerard Santema
General Manager

Contents

1.0	Introduction.....	5
1.1	General.....	5
1.2	Reception, handling and storage.....	5
1.2.1	Reception.....	5
1.2.2	Handling.....	5
1.2.3	Storage.....	5
1.3	Safety.....	6
1.3.1	General.....	6
1.3.2	Pump units.....	7
1.3.2.1	Pump unit handling.....	7
1.3.2.2	Installation.....	7
1.3.2.3	Before commissioning the pump unit.....	8
1.3.2.4	Disassembly/assembly of the coupling guard.....	8
1.3.2.5	Name plate – CE Declaration of Conformity.....	8
1.4	Pump description.....	9
1.4.1	Type designation.....	9
1.5	Function and operating principle.....	10
1.5.1	Operating principle.....	10
1.5.2	Direction of rotation - left hand or right hand.....	11
1.6	Standard parts of the pump.....	11
2.0	Technical information.....	12
2.1	Material specification.....	1
2.2	Pump versions.....	12
2.3	Shaft seals.....	12
2.3.1	Mechanical seal, type V.....	12
2.3.2	Gland packing F and R, and special version FK.....	13
2.3.3	Double lip seal, type L.....	14
2.4	Temperature.....	14
2.5	Particle size.....	14
2.6	Revolutions.....	14
2.7	Pressure.....	14
2.8	Rotor clearances.....	14
2.9	Sound level.....	15
2.10	Safety relief valves.....	15
2.10.1	Working principle.....	15
2.10.2	Built-on safety relief valves.....	16
2.10.3	Separate safety relief valves - discontinued.....	17
2.10.4	Pressure.....	17
2.10.5	Adjusting the required opening relief pressure.....	18
2.10.6	Installation/direction of flow.....	18
3.0	Capacity.....	19
3.1	TG L-range at 700 rpm.....	19
3.2	TG L-range at 900 rpm.....	20
3.3	TG L-range at 1400 rpm.....	21

4.0	Installation and maintenance	22
4.1	General	22
4.2	Installation and piping	22
4.3	Start-up.....	23
4.4	Routine check-up	23
4.5	Service and maintenance	24
	4.5.1 Replacement of mechanical seal	24
	4.5.2 Replacement of gland packing	25
	4.5.3 Replacement of lip seal	26
5.0	Trouble shooting chart.....	27
5.1	Instructions for re-using and disposal	27
	5.1.1 Re-use	27
	5.1.2 Disposal	27
6.0	Spare parts list.....	28
6.1	Spare parts for TG L-range.....	28
6.2	Built-on safety relief valves.....	30
6.3	Separate safety relief valves - discontinued	31
6.4	Counter pipe flange sets	32
6.5	Motor pedestal sets.....	33
6.6	Bracket sets.....	35
6.7	Shaft coupling sets	36
6.8	Packing and seal sets.....	37
7.0	Dimensions and weights.....	38
7.1	TG L-pump.....	38
7.2	Flanged pump unit	39
8.0	RBS4	40
8.1	General	40
8.2	Type designation.....	40
8.3	Direction of rotation - right hand as standard.....	41
8.4	Material specification.....	41
8.5	Temperature	41
8.6	Particle size.....	41
8.7	Revolutions	41
8.8	Pressure	41
8.9	Axial clearances	41
8.10	Dimensions and weights.....	41
8.11	Spare parts list.....	42
8.12	Counter pipe flange set	44
8.13	Motor Pedestal sets.....	45
8.14	Bracket sets.....	46
8.15	Shaft coupling sets	47
8.16	Packing and seal sets.....	47
8.17	Capacity for RBS4, water	48

1.0 Introduction

1.1 General

This instruction manual contains necessary information of the TG L-pumps and must be read carefully before installation, service and maintenance. The manual must be kept easily accessible to the operator.

Important!

The pump must not be used for other purposes than recommended and quoted for without consulting your supplier.



Liquids not suitable for the pump can cause damages to the pump unit and imply risk of personal injury.

1.2 Reception, handling and storage

1.2.1 Reception

Remove all packing materials immediately after reception. Check the consignment for damage immediately on arrival and make sure that the name plate/type designation is in accordance with the packing slip and your order.

In case of damage and/or missing parts, a report should be drawn up and presented to the carrier at once. Notify your supplier.

All pumps have the serial number stamped on a name plate.

This number should be stated in all correspondence with your local supplier.

The first digits of the serial number indicate the year of production.

TopGear	CE	EAC
Model: TG L		
Serial No:		
SPX		
SPX Flow Technology Belgium NV Eventbroekveld 2-6, BE-9420 Erpe-Mere		
Johnson Pump		
www.johnson-pump.com / www.spx.com		

1.2.2 Handling

Due to the fact that the weight of the pumps do not exceed 20 kg, lifting slings and lifting devices will not be necessary to lift these pumps. See section 7.0 for the weights.

In case of pump units, check the chapter 1.3.2.1 regarding the handling of these pump units.

1.2.3 Storage

If the pump is not installed immediately, it must be stored in a dry and clean place. Turn the shaft every second month and check that there is oil for protection in the pump casing.

1.3 Safety

1.3.1 General

Important!

The pump must not be used for other purposes than recommended and quoted for without consulting your local supplier.

A pump must always be installed and used in accordance with existing national and local sanitary and safety regulations and laws.

When ATEX pump/pump unit is supplied, the separate ATEX manual must be considered.



- Always wear suitable safety clothing when handling the pump.



- Anchor the pump properly before start-up to avoid personal injury and/or damage to the pump unit.



- Install shut-off valves on both sides of the pump to be able to shut off the in- and outlet before service and maintenance. Check to see that the pump can be drained without injuring anyone and without damaging the environment or nearby equipment.



- Make sure that all movable parts are properly covered to avoid personal injury.
- All electrical installation work must be carried out by authorized personnel in accordance with EN60204-1. Install a lockable circuit breaker to avoid inadvertent starting. Protect the motor and other electrical equipment from overloads with suitable equipment. The electric motors must be supplied with ample cooling air.



In environments where there is risk of explosion, motors classified as explosion safe must be used, along with special safety devices. Check with the governmental agency responsible for such precautions.



Improper electrical installation can cause fatal injuries.



- Dust, liquids and gases that can cause overheating, short circuits, corrosion damage and fire must be kept away from the motor and other exposed equipment. If the pump handles liquids hazardous for person or environment, some sort of container must be installed into which leakage can be led.



- If the surface temperature of the system or parts of the system exceeds 60°C, these areas must be marked with warning text reading "Hot surface" to avoid burns.
- The pump unit must not be exposed to rapid temperature changes of the liquid without prior pre-heating/pre-cooling. It is absolutely forbidden to flush a hot pump with cold water. Big temperature changes can cause crack formation or explosion, which in turn can entail severe personal injuries.
- The pump must not operate above stated performance.
- Before intervening in the pump/system, the power must be shut off and the starting device be locked. When intervening in the pump unit, follow the instructions for disassembly/assembly. If the instructions are not followed, the pump or parts of the pump can be damaged. It will also invalidate the warranty.
- Do not run the pump dry. If there is a risk of dry running install a suitable dry running protection to avoid serious damages.
- If the pump does not function satisfactorily, contact your supplier.

1.3.2 Pump units

1.3.2.1 Pump unit handling

Use an overhead crane, forklift or other suitable lifting device.

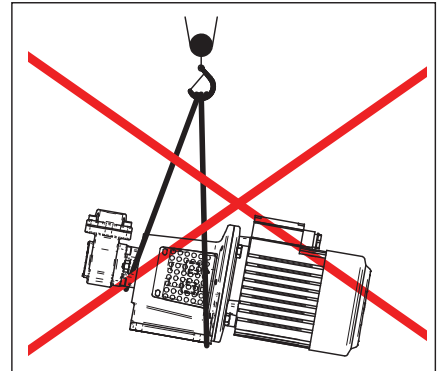
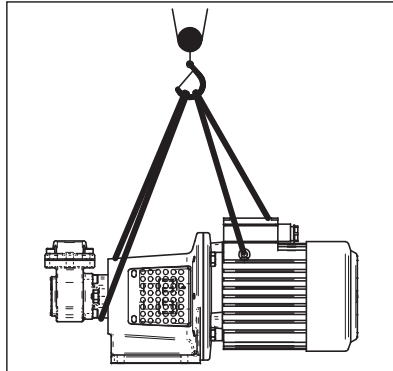
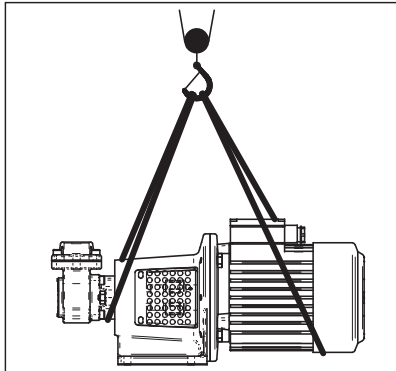
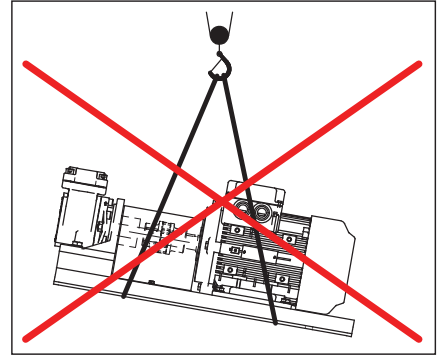
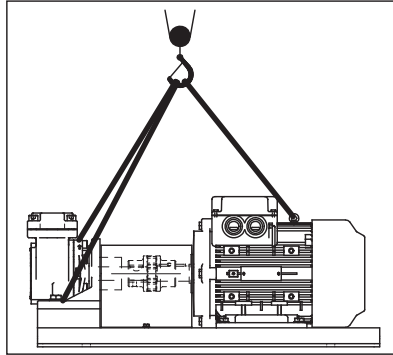
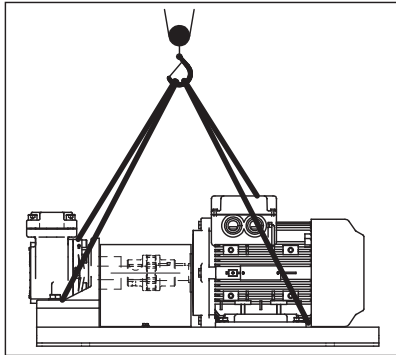

Secure lifting slings around the front part of the pump and the back part of the motor. Make sure that the load is balanced before attempting the lift.

NB! Always use two lifting slings.

If there are lifting rings on both the pump and the motor the slings may be fastened to these.

NB! Always use two lifting slings.

Warning

Never lift the pump unit with only one fastening point. Incorrect lifts can result in personal injury and/or damage to the unit.

1.3.2.2 Installation

All pump units should be equipped with a locking safety switch to prevent accidental start during installation, maintenance or other work on the unit.



Warning

The safety switch must be turned to off and locked before any work is carried out on the pump unit. Accidental start can cause serious personal injury.

The pump unit must be mounted on a level surface and either be bolted to the foundation or be fitted with rubber-clad feet.

The pipe connections to the pump must be stress-free mounted, securely fastened to the pump and well supported. Incorrectly fitted pipe can damage the pump and the system.



Warning

Electric motors must be installed by authorized personnel in accordance with EN60204-1. Faulty electrical installation can cause the pump unit and system to be electrified, which can lead to fatal injuries.

Electric motors must be supplied with adequate cooling ventilation. Electric motors must not be enclosed in airtight cabinets, hoods etc.

Dust, liquids and gases which can cause overheating and fire must be diverted away from the motor.



Warning

Pump units to be installed in potentially explosive environments must be fitted with an Ex-class (explosion safe) motor. Sparks caused by static electricity can give shocks and ignite explosions. Make sure that the pump and system are properly grounded. Check with the proper authorities for the existing regulations. A faulty installation can lead to fatal injuries.

1.3.2.3 Before commissioning the pump unit

Read the pump's operating and safety manual. Make sure that the installation has been correctly carried out according to the relevant pump's manual.

Check the alignment of the pump and motor shafts. The alignment may have been altered during transport, lifting and mounting of the pump unit. For safe disassembly of the coupling guard see below: Disassembly/assembly of the coupling guard.



Warning

The pump unit must not be used with other liquids than those for which it was recommended and sold. If there are any uncertainties contact your sales representative. Liquids, for which the pump is not appropriate, can damage the pump and other parts of the unit as well as cause personal injury.

1.3.2.4 Disassembly/assembly of the coupling guard

The coupling guard is a fixed guard to protect the users and operator from fastening and injuring themselves on the rotating shaft/shaft coupling. The pump unit is supplied with factory mounted guards with certified maximum gaps in accordance with standard DIN EN ISO 13857.



Warning

The coupling guard must never be removed during operation. The locking safety switch must be turned to off and locked. The coupling guard must always be reassembled after it has been removed. Make sure to also reassemble any extra protective covers. There is a risk of personal injury if the coupling guard is incorrectly mounted.

- a) Turn off and lock the power switch.
- b) Disassemble the coupling guard.
- c) Complete the work.
- d) Reassemble the coupling guard and any other protective covers. Make sure that the screws are properly tightened.

1.3.2.5 Name plate – CE Declaration of Conformity

Always quote the serial number on the name plate together with questions concerning the pump unit, installation, maintenance etc.

When changing the operating conditions of the pump please contact your supplier to ensure a safe and reliable working pump.

This also applies to modifications on a larger scale, such as a change of motor or pump on an existing pump unit.

TopGear CE EAC	
Model:	TG L
Serial No:	
 SPX Flow Technology Belgium NV Evenbroekveld 2-6, BE-9420 Erpe-Mere Johnson Pump www.johnson-pump.com / www.spx.com	

1.4 Pump description

TG L-range can be delivered in a number of versions depending on the pumping conditions. Each pump has a name plate on the pump casing describing the pump version, shaft seal, foot option, relief valve and the counter pipe flanges.

1.4.1 Type designation

The pump properties are encoded in the following type indications, which is to be found on the name plate.

Example:

TG L 002 - 02 V - M1 - 25 - W
1 2 3 4 5 6 7 8

1. Pump family name

TG = TopGear

2. Pump range name

L = Low viscous efficiency

3. Hydraulics indicated with displacement volume per revolution (in dm³)

TG L002

TG L004

TG L009

TG L018

TG L047

TG L095

4. Pump version

-02 = standard pump version, with standard clearances, heat treated parts, max. 140°C

-03 = pump version with increased radial and axial clearances, max. 250°C

5. Shaft seals

V = single mechanical seal

F = gland packing PTFE

FK = gland packing PTFE with stub shaft and bearing bracket – version for belt drive (only for TG L095-03)

R = gland packing of pure graphite

L = graphite impregnated PTFE double lip seal

6. Foot options

NF = no foot (with free shaft end)

BR = bracket for foot mounting (B3)

M1 = motor pedestal for B5-motor

M2 = motor pedestal for B14-motor

7. Safety relief valve

- 00 = no relief valve
- 03 = safety relief valve for working pressure range 0.5-3 bar
- 15 = safety relief valve for working pressure range 1-15 bar
- 25 = safety relief valve for working pressure range 13-25 bar
- 30 = safety relief valve for working pressure range 20-26 bar

8. Counter pipe flanges

- N = no counter pipe flanges
- W = flange set for welding
- T = threaded flange set

1.5 Function and operating principle

There are two moving parts (see figure A) – rotor (2) and idler (3). The idler is eccentrically positioned in relation to the rotor and has less teeth than the rotor. The crescent shape on the pump cover (4) acts as a seal between the suction and discharge ports and divides the liquid which is transported in the idler and rotor pockets.

1.5.1 Operating principle

A

As the rotor shaft is turned the volume of the pockets (1) between the rotor (2) and the idler (3) is increased and a vacuum is created. Liquid enters the suction port.

B

Observe the progress of the liquid through the pump and how the crescent shape (4) on the pump cover divides the liquid and acts as a seal between the suction and discharge ports.

The gear design of the idler and the rotor form locked pockets for the liquid which guarantees absolute volume control.

C

Pump in a completely flooded condition and in the process of discharging the liquid through the discharge port.

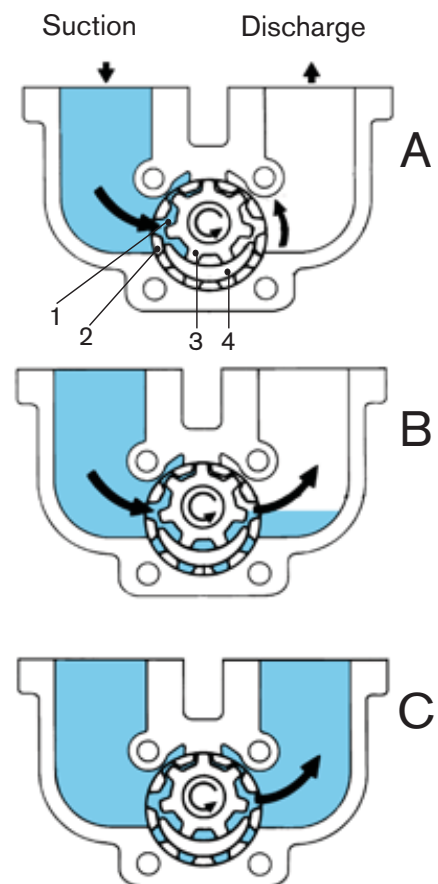

Arrows show the direction of rotation and progress of the liquid flow.

1.5.2 Direction of rotation - left hand (ccw) or right hand (cw)

Seen from the **shaft end** the TG L-pumps can be fitted for **left hand** rotation which means **suction** through the **left** hand port and **discharge** through the **right** hand port (as indicated on the picture) or vice versa (fitted for **right hand** rotation with **suction** through the **right** hand port and **discharge** through the **left** hand port). Note that the direction of rotation is part of the pump configuration.

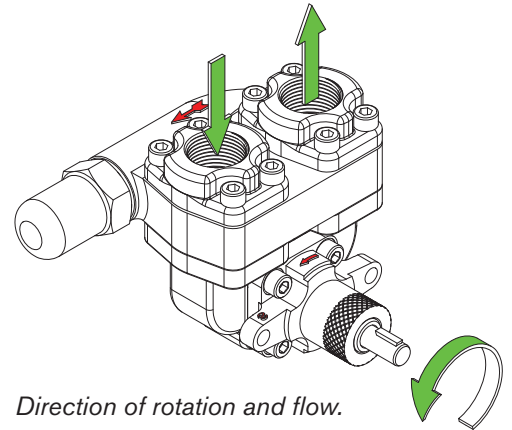

There is a thin bore connecting the seal chamber with the suction side of the pump to relieve the seal area from high pressures.

If the direction of rotation of the TG L pump is configured as right handed (cw), the intermediate casing is turned by 180° to reduce the pressure in the seal area.

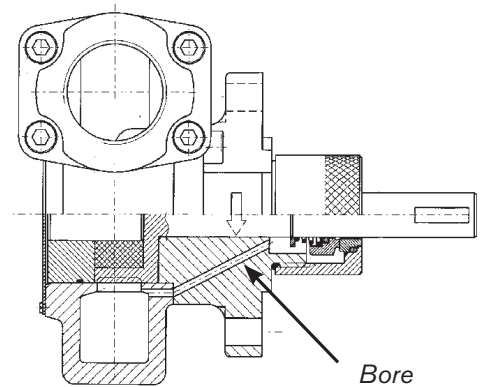

The mechanical seal type V (refer to par 2.3.1) is **dependent** on the direction of rotation; pumps equipped with this seal type are **NOT** suitable for changing the direction of rotation. For a customized solution in case of bidirectional applications, please contact your SPX Flow representative (e.g. a MG1 seal type can be offered on request).

1.6 Standard parts of the pump

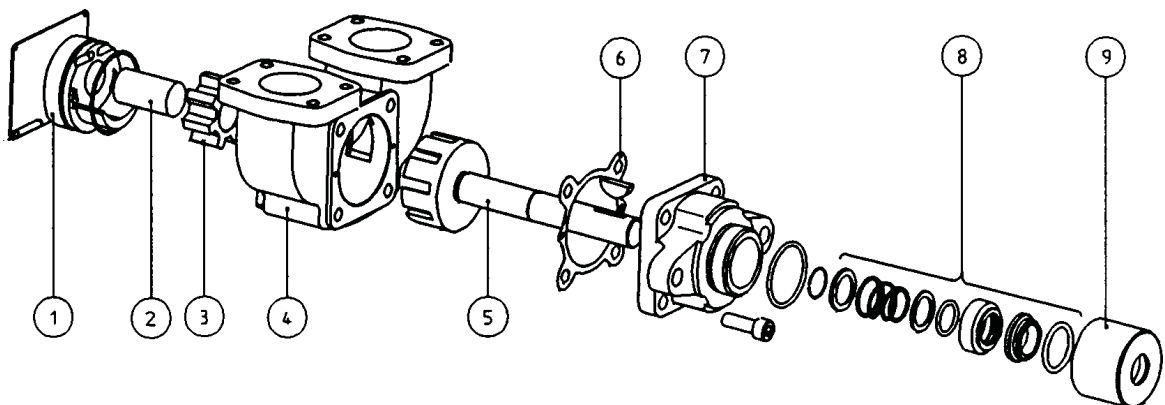

- | | | |
|---------------|-----------------------|--------------|
| 1 Pump cover | 5 Rotor | 8 Shaft seal |
| 2 Idler pin | 6 Shims | 9 Gland nut |
| 3 Idler | 7 Intermediate casing | |
| 4 Pump casing | | |

2.0 Technical information

2.1 Material specification

Pump part	DIN W-Nr.	SS	BS	AISI/SAE/ASTM
Pump casing	0.7040	SS 0717-00/140717	BS 2789 grade 420/12	ASTM A 536 60-40-18
Pump cover	0.7040	SS 0717-00/140717	BS 2789 grade 420/12	ASTM A 536 60-40-18
Intermediate casing	0.7040	SS 0717-00/140717	BS 2789 grade 420/12	ASTM A 536 60-40-18
Pipe flanges, threaded	0.7040	SS 0717-00/140717	BS 2789 grade 420/12	ASTM A 536 60-40-18
Pipe flanges, welding	1.0037	SS 1311	Fe 360 B	A 283 C
Rotor	1.6582	SS 2541	816 M 40 817 M40	4337 4340
Idler	1.5715	SS 2511	637A16 (EN352)	3115
Idler pin	1.6582	SS 2541	816 M 40 817 M40	4337 4340
O-rings	FPM (DIN/ISO)		FKM (ASTM)	

2.2 Pump versions

- 02 - Standard pump version for most liquids e.g. oils, paints and glues. Heat treated parts (nitro carburated). Max. liquid temperature 140°C.
- 03 - Pump with increased radial and axial clearances for temperatures up to 250°C and for liquids sensitive to temperature increases, e.g. heat transfer oils, polyester, glue, bitumen, sugar solutions.

2.3 Shaft seals

- V = mechanical seal
- L = PTFE double lip seal
- F = gland packing, PTFE
- R = gland packing, pure graphite

2.3.1 Mechanical seal, type V

Single mechanical seal for oils, emulsions, polyol and similar products - the seal is dependent on the direction of rotation: for each dedicated sense of rotation - left hand (CCW) or right hand (CW) - a proper unidirectional seal is selectable.

- Max viscosity: 1500 cP
- Max temperature: 175°C
- Max pressure suction side: 5 bar
- Material: carbon/steel
- O-rings of FPM (DIN/ISO) / FKM (ASTM)

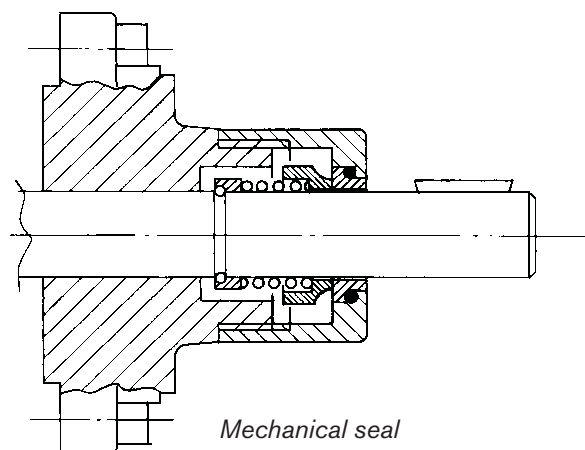

2.3.2 Gland packing F and R, and special version FK

- F Non-asbestos PTFE impregnated packing for both low and high viscous liquids. Spring loaded, self adjusting.
Max temperature: 200°C
Dimension: TG L002 - TG L004 = 1/8"
TG L009 - TG L095 = 1/4"

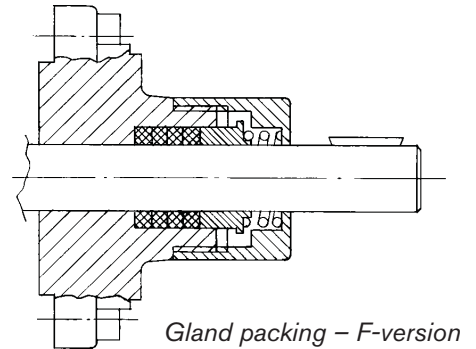

- R Gland packing rings of pure graphite with conventional gland and gland screws. Can be run dry. Chemically very good durability.
Max temperature: 300°C.

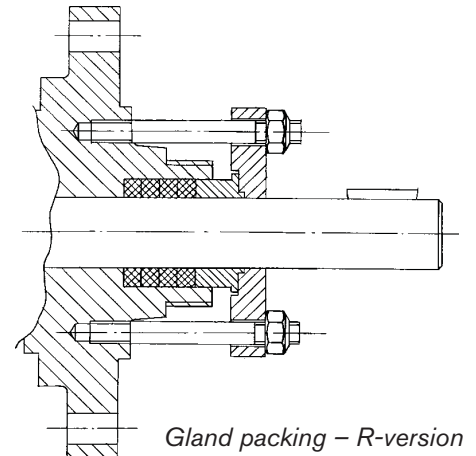

- FK A special version for belt drive is available for the TG L095 size called TG L095-03FK. It is the same as the -03F version, but with stub shaft and bearing bracket

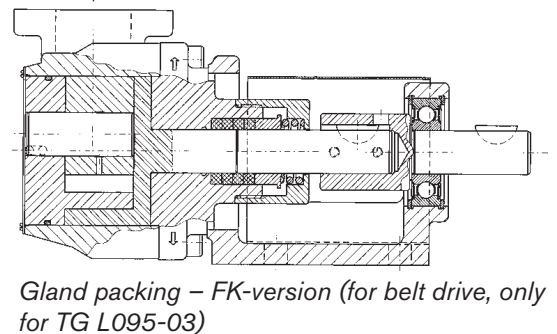

Remember that the gland packing is designed to leak somewhat to give proper lubrication.

Dimensions of stuffingbox

Pump	A	B	C
TG L002	Ø12 mm	Ø18 mm	21 mm
TG L004	Ø12 mm	Ø18 mm	21 mm
TG L009	Ø18 mm	Ø30 mm	30 mm
TG L018	Ø18 mm	Ø30 mm	30 mm
TG L047	Ø25 mm	Ø37 mm	30 mm
TG L095	Ø25 mm	Ø37 mm	30 mm

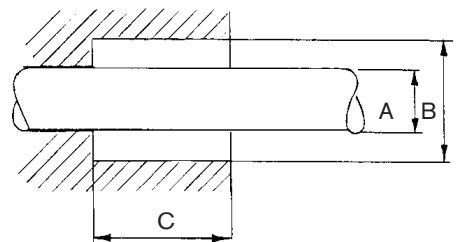

2.3.3 Double lip seal, type L

Double PTFE lip seals for quench or flush.
 For hazardous and difficult liquids e.g. isocyanate, solvents, paints and to prevent crystallization.
 Max temperature: 170°C
 Max pressure: 6 bar
 Max pressure on the suction side: 3 bar

Important! The pump is delivered without flushing liquid. The flushing liquid must be compatible with the liquid being pumped. Always maintain liquid lubrication in the seal.

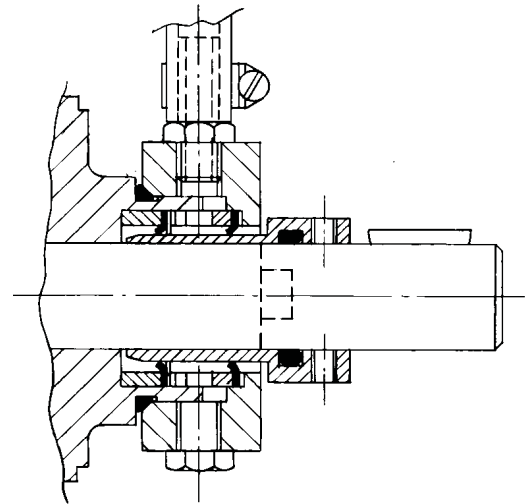

Lip seal

2.4 Temperature

With standard clearances: With increased clearances:
 Version -02: -25°C – +140°C Version -03: -25°C – +250°C

2.5 Particle size

Max size of solid particles:
 TG L002 - TG L004: 0.01 mm
 TG L009 - TG L018: 0.04 mm
 TG L047 - TG L095: 0.05 mm

2.6 Revolutions

TG L002 - TG L018: 3000 rpm at max 40 cP
 TG L047 - TG L095: 1700 rpm at max 40 cP

2.7 Pressure

For a good lubricant of at least 30-40 cP the max permissible **differential pressure** (Δp) (between suction and discharge) is:

TG L002 - TG L018: 25 bar
 TG L047 - TG L095: 8 bar

2.8 Rotor clearances

When assembling a pump the rotor clearance is important to maintain the capacity/efficiency of the pump. The following measurements apply:

	Version -02	Version -03
TG L002 - TG L004	0.02 ± 0.01 mm	0.05 ± 0.01 mm
TG L009 - TG L018	0.05 ± 0.01 mm	0.09 ± 0.01 mm
TG L047 - TG L095	0.07 ± 0.02 mm	0.12 ± 0.02 mm

The above is measured (use a dial indicator) at the shaft end when the pump is dry and clean. Correct clearance is set with shims.

2.9 Sound level

Highest measured sound level for the TG L-pumps is 74 dB(A) for a pump mounted to a standard electric motor.

2.10 Safety relief valves

2.10.1 Working principle

The positive displacement principle requires the installation of a safety device in order to protect the pump and other components in the system from excessive pressure. Such a safety device can be e.g. a slip coupling or a safety relief valve.

Special safety relief valves have been developed for the TG L-range: safety relief valves which are simply fitted on top of the pump between the pipe flanges and the pump casing, as well as safety relief valves which can be installed after the pump. Both types are spring loaded pressure relief valves that open rapidly by pop action when the working pressure increases to the set pressure on which the spring is set in advance. A choice of springs for different pressure ranges is available for both types of safety relief valves.

These safety relief valves limit the differential pressure (Δp) (or working pressure) between the suction and discharge, not the maximum pressure within the installation.

For example, as media cannot escape when the discharge side of the pump is obstructed, an over-pressure may cause severe damage to the pump. The safety relief valve provides an escape path, rerouting the media back to the suction side when reaching a specified pressure level.

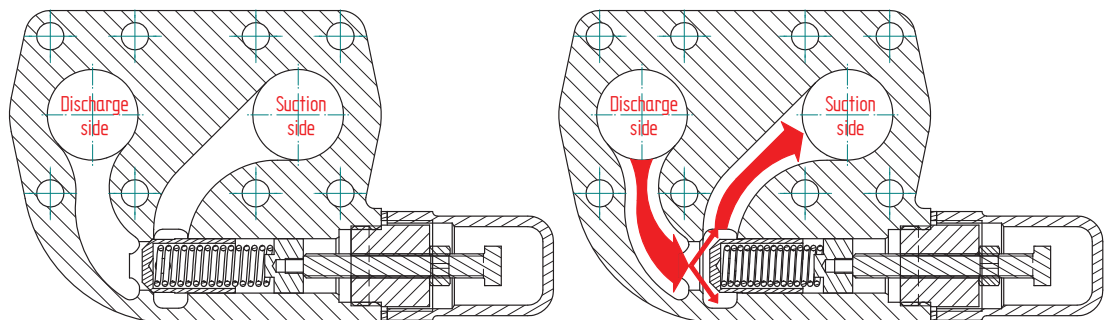

An open safety relief valve indicates that the installation is not functioning properly. The pump must be shut down at once. Find and solve the problem before restarting the pump.

2.10.2 Built-on safety relief valves

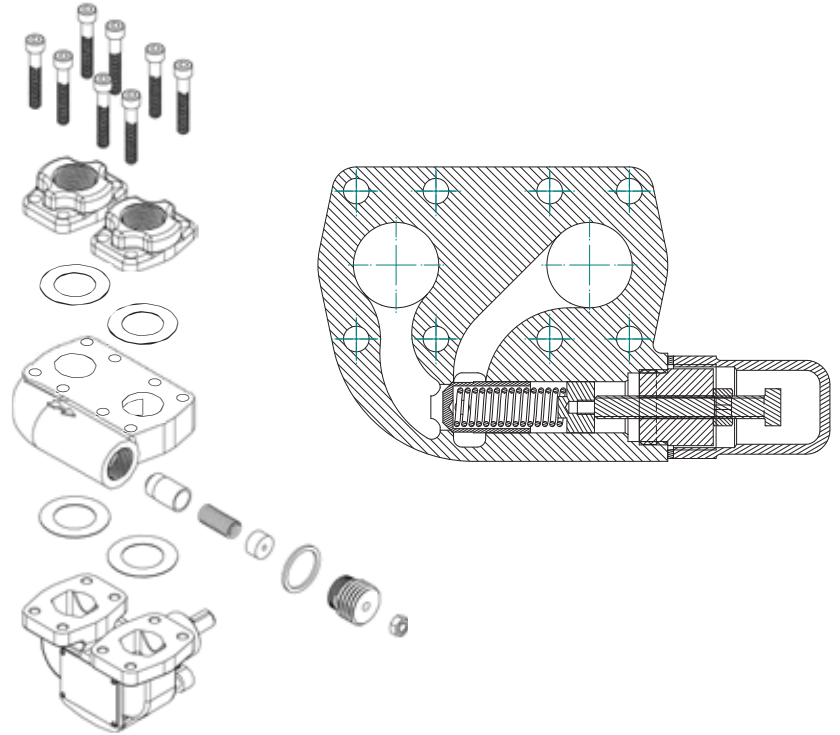

Example:

R 16 - G 25
1 2 3 4

1. Built-on safety relief valve = R

2. Type indication = inlet diameter (in mm)

- 16 built-on safety relief valve for TG L002, TG L004, TG L009 and TG L018
- 22 built-on safety relief valve for TG L047 and TG L095

3. Materials

- G safety relief valve in cast iron

4. Working pressure class

- 03 = safety relief valve for working pressure range 0,5-3 bar
- 15 = safety relief valve for working pressure range 1-15 bar
- 25 = safety relief valve for working pressure range 13-25 bar
- 30 = safety relief valve for working pressure range 20-26 bar



Note! Do not use the safety relief valve as a flow regulator. The liquid will circulate only through the pump and will heat up quickly by viscous friction losses. The temperature increases quicker at high speeds and high operating pressures.



Note! The safety relief valve protects the pump against over-pressure only in one flow direction. The safety relief valve will not provide protection against over-pressure when the pump rotates in the opposite direction.

Note that the pressure increases in the pump/system from the point when the valve starts to open until it is fully open :

- TG L002 – TG L018: pressure increases by 1.6 – 1.7 bar
- TG L047 – TG L095: pressure increases by 3.2 – 3.4 bar

2.10.3 Separate safety relief valves - discontinued

Separate safety relief valves for the TopGear L-range & RBS-series have DISCONTINUED from the standard delivery program from December 2014 on.

As the 2" execution of the separate relief valve was already removed from the program some time ago, we now took the decision to discontinue the 1" & the 1½" executions as well. This mainly because of low item demands and production related issue.

Remarks:

- Spare parts for existing separate relief valves [Pos 71, 72 and 73], sold in the past, remain available, as they are identical to the ones used in the built-on safety valves. Please refer to the latest Technical Sales Manual of 'TopGear L-range & RBS series' available on SharePoint to retrieve the corresponding article numbers & descriptions when ordering.
- The built-on safety relief valves range remain, of course, unchanged.

2.10.4 Pressure

Safety relief valves are divided into 4 working pressure classes i.e. 03, 15, 25 and 30 indicating the **maximum working pressure** for that valve.

When ordering a safety relief valve, the **set pressure** has to be mentioned. The set pressure is the pressure that will be set (and tested) during the assembly of the safety relief valve. This set pressure has to be higher than the maximum working pressure in the pump/system. A general accepted margin between the set pressure and the maximum working pressure in the pump/system is **1 bar**.

Example: maximum working pressure 18 bar = set pressure will be set at 19 bar

Thus when ordering a safety relief valve for a pump where the maximum working pressure will be 18 bar, you have to order a safety relief valve with a set pressure of 19 bar.

2.10.5 Adjusting the required opening relief pressure

In order to adjust the set pressure of a safety relief valve:

- Fit a manometer to the discharge side of the pump.
- Make sure that all the valves in the discharge line are fully opened.
- Unscrew the set screw of the safety relief valve (min. opening pressure of the valve).
- Start the pump and read the discharge pressure.
- Tighten the set screw to its maximum (max. opening pressure of the valve).
- Close the discharge line little by little, until the required opening relief pressure has been reached (look at the manometer).
- Unscrew the set screw until the valve/manometer start to “flutter”.

2.10.6 Installation/direction of flow

Since the pumps can operate in both directions (see 1.5.2 Direction of rotation), it is important that the safety relief valve is correctly fitted.

If the pump runs clockwise, seen towards the shaft end, the valve end (screw end) must point towards the right and vice versa – see pictures below

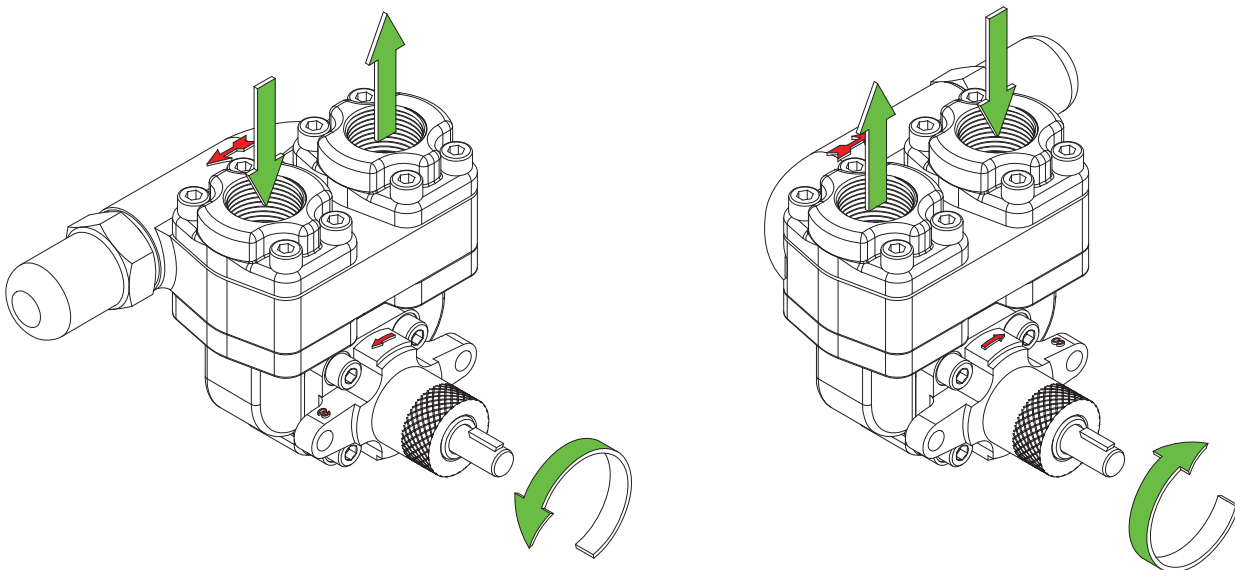

3.0 Capacity

3.1 TG L-range at 700 rpm

Pump	Viscosity	Pressure, bar											
		0		5		10		15		20		25	
		l/mn	kW	l/mn	kW	l/mn	kW	l/mn	kW	l/mn	kW	l/mn	kW
TG L002	10	1.4	0.04	1.4	0.04	1.3	0.07	1.3	0.10	1.3	0.15	-	-
	35	1.4	0.04	1.4	0.04	1.4	0.07	1.4	0.10	1.3	0.15	1.3	0.20
	75	1.5	0.04	1.5	0.05	1.4	0.07	1.4	0.11	1.4	0.15	1.3	0.19
	150	1.5	0.04	1.5	0.05	1.5	0.07	1.4	0.11	1.4	0.15	1.4	0.18
	380	1.5	0.04	1.5	0.05	1.5	0.07	1.5	0.11	1.4	0.13	1.4	0.16
	750	1.5	0.06	1.5	0.07	1.5	0.08	1.5	0.10	1.5	0.13	1.4	0.14
	1500	1.5	0.07	1.5	0.07	1.5	0.09	1.5	0.10	1.5	0.11	1.5	0.13
	2200	1.5	0.07	1.5	0.08	1.5	0.09	1.5	0.10	1.5	0.11	1.5	0.13
	4000	1.5	0.07	1.5	0.08	1.5	0.09	1.5	0.11	1.5	0.11	1.5	0.13
8000	1.5	0.08	1.5	0.09	1.5	0.10	1.5	0.11	1.5	0.11	1.5	0.13	
TG L004	10	3.1	0.04	3.0	0.04	3.0	0.08	2.9	0.13	2.9	1.18	-	-
	35	3.1	0.04	3.0	0.06	3.0	0.09	3.0	0.13	2.9	0.19	2.9	0.24
	75	3.1	0.04	3.1	0.07	3.0	0.10	3.0	0.15	3.0	0.20	2.9	0.25
	150	3.1	0.05	3.1	0.07	3.1	0.11	3.0	0.15	3.0	0.21	3.0	0.26
	380	3.1	0.06	3.1	0.10	3.1	0.13	3.1	0.18	3.0	0.22	3.0	0.26
	750	3.1	0.10	3.1	0.13	3.1	0.16	3.1	0.20	3.1	0.24	3.1	0.27
	1500	3.1	0.16	3.1	0.18	3.1	0.20	3.1	0.21	3.1	0.24	3.1	0.27
	2200	3.1	0.18	3.1	0.19	3.1	0.21	3.1	0.22	3.1	0.24	3.1	0.27
	4000	3.1	0.22	3.1	0.22	3.1	0.22	3.1	0.23	3.1	0.24	3.1	0.27
8000	3.1	0.24	3.1	0.24	3.1	0.24	3.1	0.24	3.1	0.24	3.1	0.27	
TG L009	10	6.3	0.06	6.2	0.11	6.1	0.20	5.9	0.32	5.7	0.47	-	-
	35	6.4	0.07	6.3	0.13	6.2	0.21	6.1	0.32	5.9	0.47	5.6	0.62
	75	6.5	0.10	6.4	0.15	6.3	0.24	6.2	0.35	6.0	0.48	5.8	0.63
	150	6.5	0.11	6.4	0.17	6.3	0.24	6.2	0.35	6.1	0.48	5.9	0.65
	380	6.5	0.15	6.5	0.21	6.4	0.29	6.3	0.38	6.2	0.48	6.0	0.65
	750	6.5	0.19	6.5	0.26	6.5	0.33	6.4	0.42	6.3	0.52	6.2	0.63
	1500	6.5	0.28	6.5	0.32	6.5	0.37	6.5	0.43	6.4	0.50	6.3	0.57
	2200	6.5	0.38	6.5	0.40	6.5	0.43	6.5	0.46	6.5	0.49	6.5	0.56
	4000	6.5	0.40	6.5	0.43	6.5	0.48	6.5	0.49	6.5	0.50	6.5	0.56
8000	6.5	0.55	6.5	0.55	6.5	0.56	6.5	0.56	6.5	0.56	6.5	0.56	
TG L018	10	12.7	0.07	12.3	0.14	12.0	0.24	11.6	0.37	11.2	0.54	-	-
	35	12.7	0.08	12.5	0.15	12.2	0.26	11.8	0.40	11.5	0.57	11.1	0.74
	75	12.8	0.12	12.6	0.19	12.3	0.29	12.0	0.43	11.6	0.57	11.3	0.74
	150	12.9	0.19	12.6	0.28	12.4	0.37	12.2	0.51	12.0	0.62	11.7	0.77
	380	12.9	0.25	12.8	0.36	12.5	0.43	12.4	0.58	12.2	0.65	12.0	0.81
	750	12.9	0.28	12.8	0.39	12.7	0.47	12.6	0.60	12.6	0.71	12.5	0.85
	1500	12.9	0.36	12.9	0.43	12.9	0.51	12.8	0.63	12.7	0.74	12.7	0.85
	2200	12.9	0.49	12.9	0.54	12.9	0.60	12.9	0.66	12.9	0.77	12.9	0.88
	4000	12.9	0.62	12.9	0.74	12.9	0.75	12.9	0.75	12.9	0.81	12.9	0.88
8000	12.9	0.83	12.9	0.84	12.9	0.85	12.9	0.87	12.9	0.87	12.9	0.89	
Pressure, bar		0		5		8							
TG L047	10	31.0	0.15	30.6	0.41	29.5	0.85						
	35	31.0	0.22	30.8	0.50	30.0	0.92						
	75	32.0	0.26	31.5	0.56	31.0	1.01						
	150	33.0	0.33	32.7	0.72	32.0	1.10						
	380	33.5	0.52	33.0	0.96	32.7	1.20						
	750	33.5	0.74	33.0	1.12	32.8	1.32						
	1500	33.5	1.03	33.0	1.25	32.8	1.47						
	2200	33.5	1.25	33.0	1.38	32.8	1.55						
	4000	33.5	1.62	33.0	1.65	32.8	1.67						
8000	33.5	1.75	33.0	1.80	32.8	1.86							
TG L095	10	62.0	0.18	61.0	0.86	60.0	1.77						
	35	63.0	0.28	62.0	0.96	61.0	1.84						
	75	64.0	0.40	63.3	1.07	62.5	1.91						
	150	65.0	0.52	64.3	1.18	63.5	2.00						
	380	66.0	0.74	65.3	1.40	64.5	2.10						
	750	67.0	1.07	66.5	1.62	66.0	2.20						
	1500	67.0	1.40	66.5	1.84	66.0	2.32						
	2200	67.0	1.84	66.5	2.10	66.0	2.43						
	4000	67.0	2.33	66.5	2.49	66.0	2.52						
8000	67.0	2.55	66.5	2.60	66.0	2.85							

The above values apply when the pump operates with a manometric suction lift of 4 meters or 13 feet water column. Capacity tolerance $\pm 5\%$. The kW-power stated are those required at the pump shaft. When selecting size of motor, the kW-rating should be 15% higher than the value indicated.

3.2 TG L-range at 900 rpm

Pump	Viscosity	Pressure, bar											
		0		5		10		15		20		25	
	cP	l/mn	kW	l/mn	kW	l/mn	kW	l/mn	kW	l/mn	kW	l/mn	kW
TL L002	10	1.9	0.04	1.8	0.05	1.8	0.08	1.7	0.13	1.7	0.18	-	-
	35	2.0	0.04	1.9	0.06	1.9	0.09	1.8	0.13	1.7	0.18	1.6	0.24
	75	2.0	0.04	2.0	0.06	1.9	0.09	1.8	0.13	1.8	0.18	1.7	0.22
	150	2.0	0.04	2.0	0.07	2.0	0.10	1.9	0.13	1.9	0.18	1.8	0.22
	380	2.0	0.07	2.0	0.09	2.0	0.11	2.0	0.14	1.9	0.18	1.9	0.22
	750	2.0	0.07	2.0	0.09	2.0	0.11	2.0	0.14	2.0	0.16	1.9	0.18
	1500	2.0	0.10	2.0	0.11	2.0	0.13	2.0	0.14	2.0	0.16	2.0	0.18
	2200	2.0	0.10	2.0	0.11	2.0	0.13	2.0	0.14	2.0	0.16	2.0	0.18
	4000	2.0	0.11	2.0	0.12	2.0	0.13	2.0	0.14	2.0	0.16	2.0	0.18
8000	2.0	0.12	2.0	0.13	2.0	0.14	2.0	0.15	2.0	0.16	2.0	0.18	
TG L004	10	3.9	0.04	3.8	0.07	3.8	0.11	3.7	0.17	3.7	0.24	-	-
	35	4.0	0.05	3.9	0.08	3.9	0.12	3.8	0.17	3.7	0.24	3.7	0.30
	75	4.0	0.05	3.9	0.08	3.9	0.13	3.8	0.18	3.8	0.25	3.8	0.32
	150	4.0	0.06	3.9	0.10	3.9	0.15	3.9	0.20	3.8	0.26	3.8	0.32
	380	4.0	0.08	4.0	0.13	3.9	0.18	3.9	0.23	3.9	0.28	3.9	0.32
	750	4.0	0.13	4.0	0.16	4.0	0.21	4.0	0.25	4.0	0.29	4.0	0.33
	1500	4.0	0.18	4.0	0.21	4.0	0.24	4.0	0.26	4.0	0.29	4.0	0.33
	2200	4.0	0.24	4.0	0.25	4.0	0.27	4.0	0.29	4.0	0.32	4.0	0.35
	4000	4.0	0.29	4.0	0.30	4.0	0.30	4.0	0.31	4.0	0.32	4.0	0.35
8000	4.0	0.33	4.0	0.34	4.0	0.35	4.0	0.35	4.0	0.36	4.0	0.36	
TG L009	10	8.1	0.10	8.0	0.17	7.8	0.27	7.6	0.41	7.4	0.59	-	-
	35	8.2	0.11	8.1	0.18	7.9	0.27	7.8	0.41	7.6	0.59	7.3	0.77
	75	8.3	0.14	8.2	0.21	8.0	0.32	7.9	0.45	7.7	0.60	7.5	0.78
	150	8.3	0.16	8.3	0.23	8.1	0.32	8.0	0.47	7.8	0.60	7.6	0.78
	380	8.3	0.21	8.3	0.29	8.2	0.38	8.1	0.49	8.0	0.60	7.8	0.77
	750	8.3	0.29	8.3	0.36	8.3	0.44	8.2	0.53	8.1	0.63	8.0	0.74
	1500	8.3	0.36	8.3	0.42	8.3	0.49	8.3	0.55	8.2	0.63	8.1	0.72
	2200	8.3	0.52	8.3	0.54	8.3	0.57	8.3	0.60	8.3	0.65	8.2	0.71
	4000	8.3	0.60	8.3	0.60	8.3	0.62	8.3	0.67	8.3	0.67	8.2	0.71
8000	8.3	0.70	8.3	0.75	8.3	0.80	8.2	0.82	8.2	0.85	8.2	0.86	
TG L018	10	16.2	0.12	15.7	0.20	15.4	0.31	15.0	0.47	14.4	0.66	-	-
	35	16.5	0.13	16.2	0.23	15.8	0.35	15.2	0.52	14.8	0.71	14.3	0.91
	75	16.6	0.18	16.3	0.27	15.9	0.40	15.5	0.56	15.0	0.75	14.6	0.94
	150	16.7	0.21	16.4	0.32	16.0	0.44	15.6	0.60	15.4	0.81	15.1	0.99
	380	16.7	0.29	16.6	0.40	16.2	0.53	15.9	0.68	15.7	0.85	15.4	1.03
	750	16.7	0.37	16.6	0.48	16.4	0.60	16.2	0.77	16.2	0.92	16.1	1.10
	1500	16.7	0.54	16.7	0.63	16.7	0.74	16.5	0.88	16.5	0.99	16.4	1.14
	2200	16.7	0.70	16.7	0.77	16.7	0.85	16.7	0.92	16.7	1.03	16.7	1.18
	4000	16.7	0.98	16.7	1.05	16.7	1.06	16.7	1.08	16.7	1.12	16.7	1.26
8000	16.7	1.40	16.7	1.42	16.7	1.44	16.7	1.45	16.7	1.45	16.7	1.45	
Pressure, bar		0		5		8							
TG L047	10	40.0	0.22	38.5	0.55	37.0	1.07						
	35	40.0	0.37	39.0	0.68	38.0	1.16						
	75	40.0	0.40	39.5	0.77	38.5	1.29						
	150	41.0	0.49	40.6	0.90	40.0	1.40						
	380	42.0	0.74	41.2	1.10	40.5	1.55						
	750	42.0	1.03	41.2	1.32	40.5	1.69						
	1500	42.0	1.40	41.2	1.69	40.5	1.99						
	2200	42.0	1.69	41.2	1.84	40.5	2.06						
	4000	42.0	2.15	41.2	2.17	40.5	2.25						
8000	42.0	2.40	41.2	2.45	40.5	2.50							
TG L095	10	80.0	0.29	78.5	1.14	77.0	2.20						
	35	80.0	0.46	78.5	1.25	77.0	2.36						
	75	82.0	0.59	80.5	1.44	79.0	2.50						
	150	84.0	0.74	82.5	1.55	81.0	2.50						
	380	84.0	0.99	83.0	1.84	81.8	2.80						
	750	84.0	1.47	83.0	2.13	81.8	2.94						
	1500	84.0	2.02	83.0	2.58	81.8	3.16						
	2200	84.0	2.33	83.0	2.87	81.8	3.24						
	4000	84.0	3.09	83.0	3.41	81.8	3.42						
8000	84.0	3.50	83.0	3.74	81.8	3.82							

The above values apply when the pump operates with a manometric suction lift of 4 meters or 13 feet water column. Capacity tolerance $\pm 5\%$. The kW-power stated are those required at the pump shaft. When selecting size of motor, the kW-rating should be 15% higher than the value indicated.

3.3 TG L-range at 1400 rpm

Pump	Viscosity	Pressure, bar												
		0		5		10		15		20		25		
	cP	l/mn	kW	l/mn	kW	l/mn	kW	l/mn	kW	l/mn	kW	l/mn	kW	
TG L002	10	3.0	0.04	2.9	0.07	2.9	0.11	2.8	0.17	2.7	0.25	-	-	
	35	3.1	0.05	3.0	0.07	2.9	0.12	2.9	0.18	2.8	0.26	2.8	0.34	
	75	3.2	0.06	3.1	0.09	3.0	0.13	2.9	0.19	2.9	0.26	2.8	0.33	
	150	3.2	0.07	3.2	0.10	3.1	0.15	3.0	0.20	3.0	0.26	2.9	0.33	
	380	3.2	0.11	3.2	0.14	3.2	0.18	3.1	0.22	3.1	0.27	3.0	0.33	
	750	3.2	0.15	3.2	0.18	3.2	0.21	3.2	0.24	3.1	0.28	3.0	0.32	
	1500	3.2	0.18	3.2	0.21	3.2	0.23	3.2	0.26	3.2	0.29	3.1	0.32	
	2200	3.2	0.21	3.2	0.22	3.2	0.24	3.2	0.26	3.2	0.29	3.2	0.31	
	8000	3.2	0.23	3.2	0.24	3.2	0.25	3.2	0.26	3.2	0.30	3.2	0.31	
TG L004	10	6.1	0.05	6.0	0.09	6.0	0.16	5.9	0.24	5.8	0.34	-	-	
	35	6.2	0.07	6.1	0.11	6.1	0.18	6.0	0.25	5.9	0.35	5.9	0.44	
	75	6.2	0.07	6.2	0.12	6.1	0.18	6.0	0.26	6.0	0.36	5.9	0.46	
	150	6.2	0.10	6.2	0.15	6.2	0.22	6.1	0.29	6.0	0.38	6.0	0.46	
	380	6.2	0.21	6.2	0.27	6.2	0.33	6.2	0.38	6.1	0.40	6.1	0.48	
	750	6.2	0.19	6.2	0.28	6.2	0.33	6.2	0.38	6.2	0.42	6.1	0.49	
	1500	6.2	0.26	6.2	0.29	6.2	0.34	6.2	0.39	6.2	0.44	6.2	0.50	
	2200	6.2	0.30	6.2	0.33	6.2	0.36	6.2	0.40	6.2	0.44	6.2	0.50	
	8000	6.2	0.37	6.2	0.39	6.2	0.39	6.2	0.41	6.2	0.44	6.2	0.50	
TG L009	10	12.8	0.15	12.5	0.26	12.2	0.41	11.8	0.62	11.4	0.87	-	-	
	35	12.9	0.18	12.6	0.29	12.4	0.46	12.0	0.66	11.6	0.88	11.2	1.15	
	75	13.0	0.21	12.8	0.33	12.6	0.50	12.2	0.70	11.8	0.92	11.4	1.16	
	150	13.0	0.27	13.0	0.38	12.8	0.53	12.5	0.74	12.2	0.92	11.9	1.16	
	380	13.0	0.38	13.0	0.49	12.9	0.63	12.7	0.77	12.4	0.96	12.1	1.18	
	750	13.0	0.47	13.0	0.59	13.0	0.72	12.9	0.88	12.8	1.03	12.6	1.18	
	1500	13.0	0.61	13.0	0.70	13.0	0.81	13.0	0.92	12.9	1.03	12.8	1.19	
	2200	13.0	0.77	13.0	0.81	13.0	0.88	13.0	0.96	13.0	1.07	12.9	1.19	
	8000	13.0	1.00	13.0	1.00	13.0	1.00	13.0	1.04	13.0	1.12	12.9	1.20	
TG L018	10	25.5	0.18	24.7	0.32	24.0	0.53	23.3	0.77	22.5	1.05	-	-	
	35	26.0	0.21	25.3	0.37	24.6	0.59	23.7	0.85	23.1	1.12	22.3	1.40	
	75	26.0	0.25	25.4	0.44	24.7	0.68	24.1	0.93	23.4	1.18	22.8	1.46	
	150	26.0	0.33	25.5	0.52	24.9	0.77	24.4	1.03	24.0	1.29	23.5	1.55	
	380	26.0	0.69	25.8	0.87	25.3	1.05	24.8	1.18	24.5	1.44	24.1	1.96	
	750	26.0	0.69	25.8	0.88	25.6	1.10	25.3	1.32	25.2	1.54	25.1	1.80	
	1500	26.0	1.03	26.0	1.18	26.0	1.36	25.8	1.55	25.7	1.73	25.6	1.91	
	2200	26.0	0.32	26.0	1.40	26.0	1.55	26.0	1.66	26.0	1.84	26.0	2.02	
	8000	26.0	1.70	26.0	1.80	26.0	1.84	26.0	1.90	26.0	2.00	26.0	2.25	
Pressure, bar	0	0	0	0	0	0	0	0	0	0	0	0	0	
	5	5	5	5	5	5	5	5	5	5	5	5	5	
	8	8	8	8	8	8	8	8	8	8	8	8	8	
	TG L047	10	62.0	0.37	61.0	0.85	59.0	1.55						
		35	62.0	0.49	61.0	1.03	59.5	1.77						
		75	63.0	0.74	62.0	1.21	61.0	1.91						
		150	64.0	1.20	63.0	1.62	62.0	2.34						
		380	65.0	1.48	64.0	2.33	63.0	2.85						
		750	66.0	1.69	65.0	2.54	64.0	3.07						
1500		66.0	2.36	65.0	2.80	64.0	3.24							
2200		66.0	2.58	65.0	2.83	64.0	3.24							
8000		66.0	3.11	65.0	3.30	64.0	3.44							
TG L095	10	125.0	0.52	122.5	1.84	119.0	3.39							
	35	125.0	0.59	122.5	1.95	119.0	3.53							
	75	125.0	0.96	123.0	2.20	120.0	3.68							
	150	125.0	1.18	124.5	2.43	124.0	3.97							
	380	130.0	1.73	128.0	3.02	125.5	4.42							
	750	130.0	2.20	128.0	3.46	126.0	4.71							
	1500	132.0	3.31	130.0	4.05	128.0	5.00							
	2200	132.0	4.12	130.0	4.42	128.0	5.08							
	8000	132.0	5.00	130.0	5.10	128.0	5.31							

The above values apply when the pump operates with a manometric suction lift of 4 meters or 13 feet water column. Capacity tolerance $\pm 5\%$. The kW-power stated are those required at the pump shaft. When selecting size of motor, the kW-rating should be 15% higher than the value indicated.

4.0 Installation and maintenance

4.1 General

- The pump unit must be thoroughly fastened.
- The pump unit must be provided with a lockable circuit breaker.
- Before any service or maintenance in the pump or system, shut off the power and lock the starting device to prevent inadvertent starting. The pump must be separated from the pipelines and power. If the pump is used for aggressive/dangerous liquids, drain the pump and the system.
- Always install a suitable safety relief valve or other safety equipment to prevent overloads of the pump or pump system.
- The pump can be installed horizontally or vertically but not with the connections downwards unless the liquid storage tank is placed above the pump (flooded pump).

4.2 Installation and piping

- If the pump and drive is mounted on a base plate **the alignment of the pump and the motor shaft must be carefully checked** after the foundation bolts have been tightened and the pipings have been connected. Even small deviations must be corrected. The clearance between the coupling halves should be approximately 2 mm.

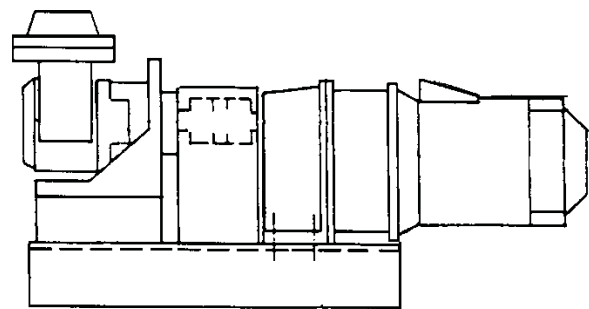

Check with a steel rule or ruler at four different places around the machined surfaces of the coupling (a). The length of the coupling should be equal and is measured at four different places of the periphery of the coupling halves (b).

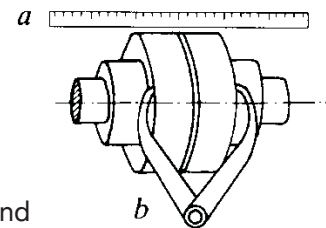

- Check that all pipelines are correctly aligned with the pump ports and **relieved from stress** to prevent loads from being transferred to the pump. Use pipes of correct size and material. All pipelines must be thoroughly cleaned. Seal the pipe joints with a suitable material.
- If the pump and motor are mounted to a flange pedestal the alignment is automatically achieved by means of guides for both motor and pump.
- Check that the pipe flanges fit well against the pump flanges before they are tightened.
- If a shut-off valve is installed in the discharge piping system a safety relief valve should always be mounted between the pump and the shut-off valve. This is to protect the pump from excessive pressures if the shut-off valve is closed when the pump is running. If the pump is provided with a built-on safety valve it must be mounted in such a way, that the arrow on the valve casing points towards the direction of rotation.
- Springs for different pressure ranges are available. When changing the spring, the protection cap nut is unscrewed. The rear seat of the spring has a metric 5 or 6 mm thread which can be used to lift the seat. Fasten the protection cap nut.
- **Clean the piping system very carefully before start up, especially the suction side, so that no burr and impurities remain.**

4.3 Start-up

- Open all valves in the piping system and make sure that there are no obstructions in the pipeline.
- Fill the pump with liquid.
- Check that all safety devices are properly installed, and that all movable parts are properly covered to avoid personal injury.

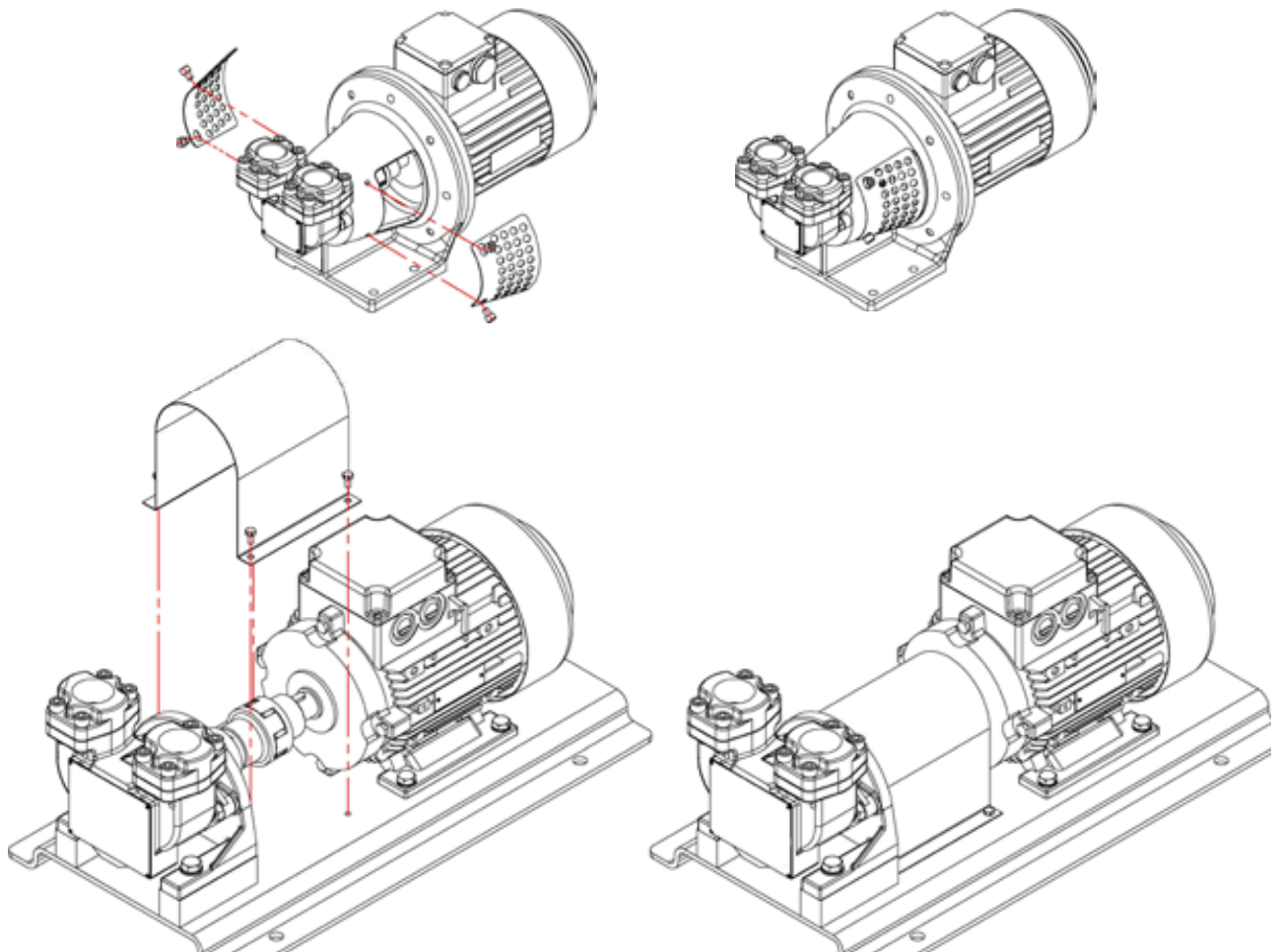

The protective cover must always be fitted prior to start-up to avoid personal injuries.

- First jog start the pump and check that the direction of rotation is correct - see rotation arrow on the intermediate casing.
- Start the pump and check the liquid flow rate. If it is not correct, stop the pump and follow the trouble shooting chart.
- Check the pressure, temperature and capacity.
- If the pump is supplied with a gland packing, allow a small leakage to lubricate and cool the gland packing. Adjust the leakage with the gland nut.

4.4 Routine check-up

- Regularly check that the sound level, vibrations and the pump temperature are normal.
- Check that no abnormal leakage occurs.
- Check the discharge pressure and flow regularly.
- Check the pump shaft seal and other wearing parts. Change when necessary.

4.5 Service and maintenance

4.5.1 Replacement of mechanical seal

1. Remove the coupling half and the shaft key.
2. Remove burr from the shaft and its keyway.
3. Unscrew the gland nut and remove all parts (101-108) from the shaft.
4. Replace the O-ring (13).
5. Fit the circlip (101) and check that it is located in the shaft groove and then fit the inner washer (102) with **the bevel towards the circlip**.
6. Slide the spring (103) and the outer washer (104) onto the shaft.
Fit the O-ring/packing (105) and ensure that it is not damaged by the keyway.
7. Fit the rotary ring (106). Press the O-ring (108) into place on the back side of the stationary ring (107). Check that the sealing surfaces are clean and without damages. Fit the stationary ring (107) in the gland nut.
8. Fasten the gland nut properly and fit the key. Mount the coupling half by means **of light tapping** and lock it with the stop screw.

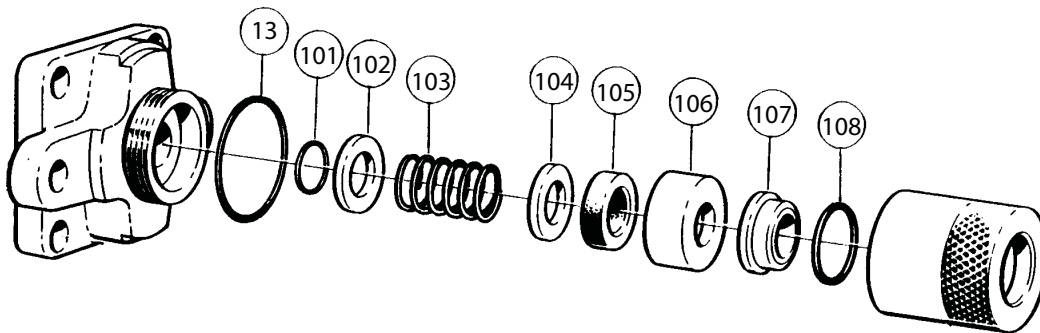

4.5.2 Replacement of gland packing

F All TG L-pumps

1. Remove the shaft key and release the gland nut (15), spring (19) and the gland (18).
2. Remove the packing braids (17) and replace them with new ones.
Note - put the joints of the gland packings with 90° shifting.

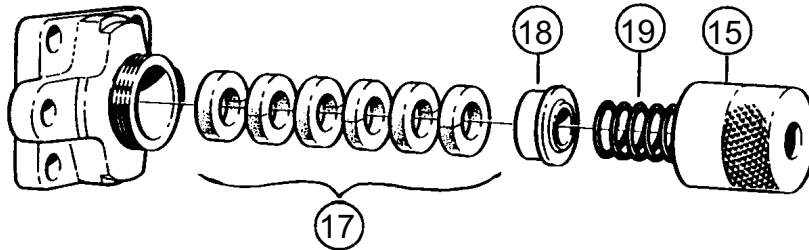

Gland packing, type F
TG L-range

R TG L002 - TG L018

1. Remove the shaft key (9), gland nut (46), distance ring (45) and gland (43).
2. Remove the old graphite rings (42).
3. Press the new rings into the the stuffing box.

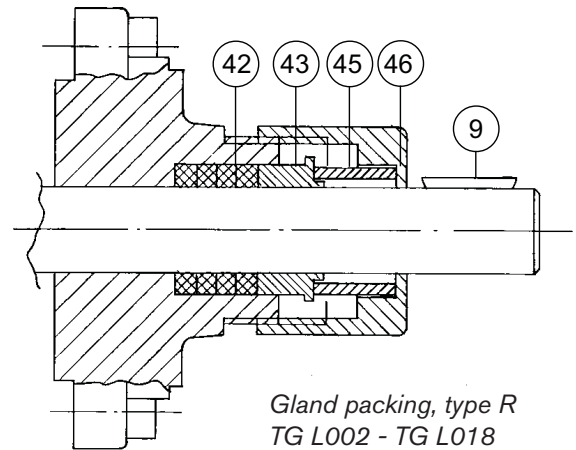

Gland packing, type R
TG L002 - TG L018

R TG L047 - TG L095

1. Remove the shaft key (9) and release the gland nuts (48), yoke (47) and gland (43).
2. Remove the old graphite rings (42).
3. Press the new rings into the stuffing box.

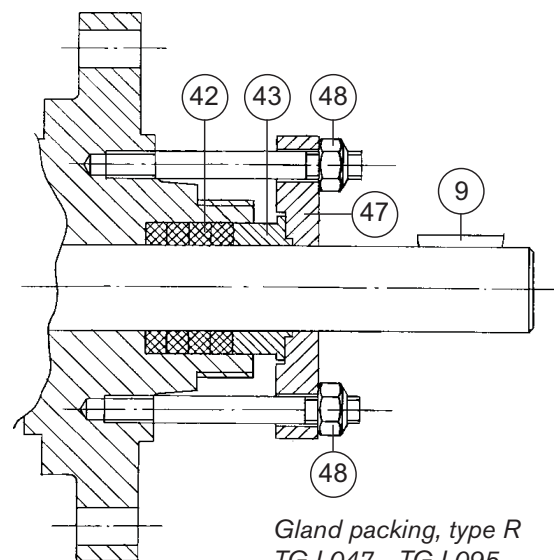

Gland packing, type R
TG L047 - TG L095

4.5.3 Replacement of lip seal

All TG L-pumps

1. Remove the coupling halves and the shaft key.
2. Remove burr, if any, from the pump shaft and its keyway.
3. Unscrew the stop screws (31) and remove the wearing sleeve (29) and O-ring (30).
4. Unscrew the screws (32) holding the seal housing (35). Remove the seal housing and the O-ring/gasket (36).

TG L002 - TG L018 (see figure below to the left)

5. Remove the lip seals (28) from the seal housing (35).
6. Fit the new lip seals (28) in the seal housing (35).

TG L047 - TG L095 (see figure below to the right)

5. Remove the rubber gaskets, lip seals and the sleeves in the intermediate casing (33) and the seal housing (35).
6. Fit the distance ring (39), lip seal (28), washer (41), gasket (40) and the lantern ring (37) to the intermediate casing (33) in said order. Fit the gasket (40) and the lip seal (28) in the seal housing (35).

All TG L-pumps

7. Check that the O-ring/gasket (36) is not damaged and fit the O-ring/gasket and the seal housing (35) to the pump.
8. Fit the O-ring (30) into the groove in the wearing sleeve (29) and slide the sleeve onto the pump shaft. Tighten the stop screws (31).
9. Fit the key and the coupling half to the pump shaft by **means of light tapping** and lock it with the stop screws.

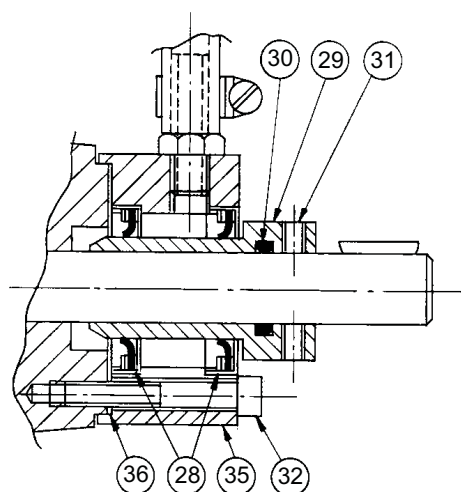

Lip seal
TG L002 - TG L018

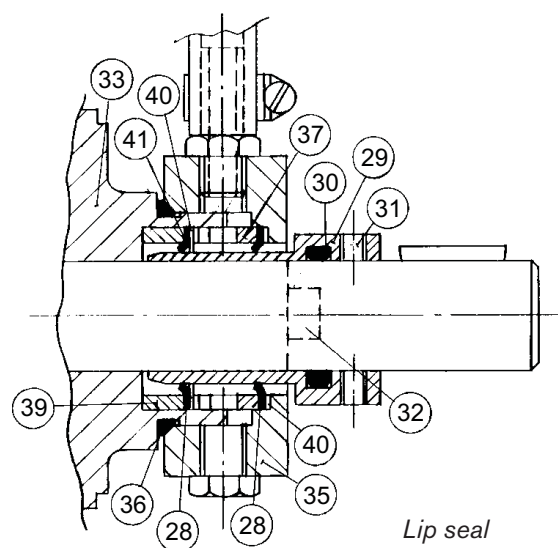

Lip seal
TG L047 - TG L095

5.0 Trouble shooting chart

Problem	Possible cause	Remedy
No flow when pump is running.	Wrong direction of rotation.	Reverse rotation.
	Air pockets in suction pipe.	Fill the suction line. Evacuate all air.
	Clogged check-valve.	Clean the check-valve.
	Pump is priming air through unsealed suction line or through shaft seal.	Check and seal the suction line. If necessary replace the shaft seal
Insufficient capacity and/or capability.	Clogged check-valve.	Clean check-valve.
	Air leakage.	Check and seal the suction line. If necessary replace the shaft seal.
	NPSH too low (manometric suction lift too high).	Increase the suction pipe diameter and/or shorten the suction pipe. Decrease the manometric suction lift.
	Pump is worn.	Check the rotor clearance. If necessary, reduce the rotor clearance by removing shims.
	Safety relief valve opens too early or does not close.	Adjust the opening pressure. Check the valve mechanism.
Noise in the pump.	Cavitation – manometric suction lift too high.	Increase the suction pipe diameter and/or shorten the suction pipe. Decrease the suction lift. Check the filters/strainers on the suction side.
	Rotor/idler damages.	Check and replace if necessary.
	Incorrect alignment Pump/drive shaft	Correct with shims/washers.
	Vibrating noise from the safety relief valve.	Increase the pressure on the spring. Replace if necessary.

5.1 Instructions for re-using and disposal

5.1.1 Re-use

Re-use or putting the pump out of service should only be undertaken after complete draining and cleaning of the internal parts.



Note! When doing so, observe adequate safety regulations and take environmental protection measures. Liquids should be drained and following local safety regulations the correct personal equipment should be used.

5.1.2 Disposal

Disposal of the pump should only be done after it has been completely drained. Proceed according to local regulations.

Where applicable please disassemble the product and recycle the part's material.

6.0 Spare parts list

How to order spares

When ordering spare parts, please state: 1. Pump type and serial number (see name plate)
2. Position number, quantity and description

Example:

1. Pump type: TG L002-02V-M3-25-W
Serial number: 2009-403001
2. Pos 7, 1, idler

6.1 Spare parts for TG L-range

Pos	Description	Qty.	Pos	Description	Qty.	Pos	Description	Qty.
2	Pump casing	1	23	Gasket	2	42	Gland packing, set, type R	1
3	Idler pin	1	24	Threaded pipe flange	2	43	Gland	1
4	Pump cover	1	25	Welding flange	2	44	Intermediate casing	1
5	O-ring	1	26	Screw	4	45	Distance ring	1
6	Pin	2	27	Name plate	1	46	Gland nut	1
7	Idler	1	28	Lip seal, type L	2	47	Yoke	1
8	Rotor	1	29	Wear sleeve	1	48	Nut	2
9	Key	1	30	O-ring	1	49	Stud bolt	2
10	Shims	x	31	Stop screw	2	50	Hose	1
11	Intermediate casing	1	32	Screw	2	51	Hose clamp	1
12	Mechanical seal, type V	1	33	Intermediate casing	1	60	Bracket	1
13	O-ring	1	34	Hose socket	1	61	Ball bearing	1
15	Gland nut	1	35	Seal housing	1	62	Circlip	2
16	Intermediate casing	1	36	Gasket/O-ring	1	63	Shaft	1
17	Gland packing, set, type F	1	37	Lantern ring	1	64	Set screw	2
18	Gland	1	38	Plug	1	65	Tap bolt	2
19	Gland spring	1	39	Distance ring	1	66	Nut	2
21	Screw	4-6	40	Rubber gasket	2	67	Key	1
22	Screw	8	41	Distance ring	1	68	Coupling guard	1

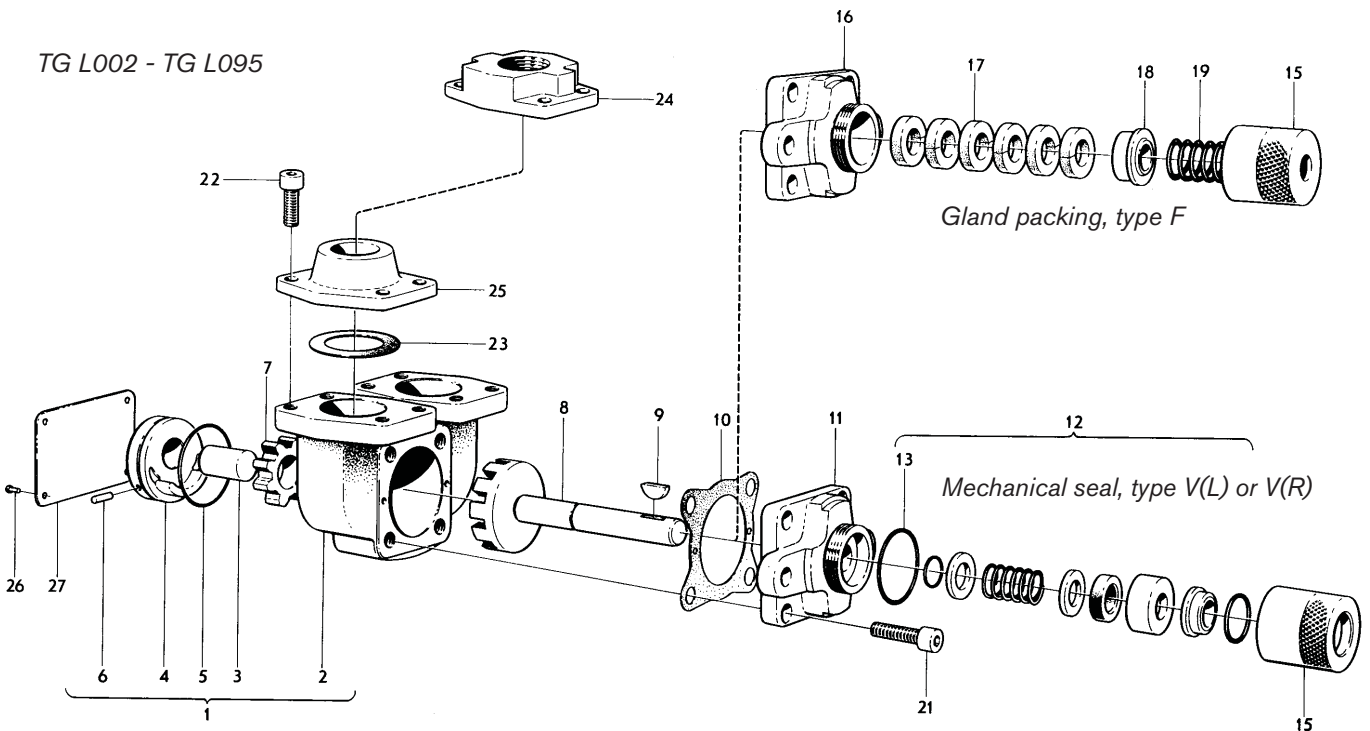

Cont'd next page

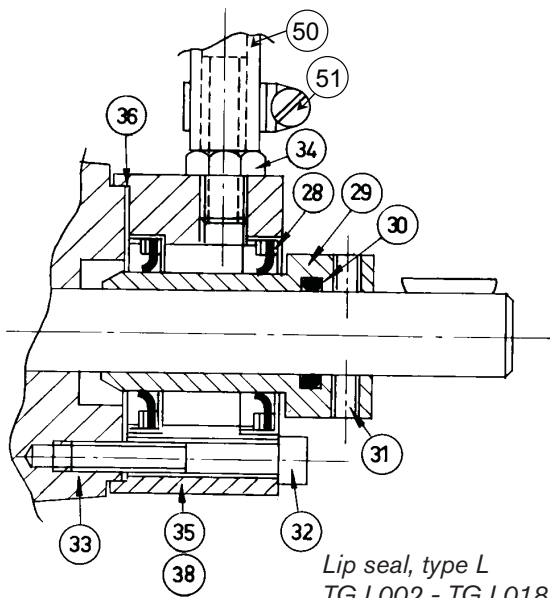

Lip seal, type L
TG L002 - TG L018

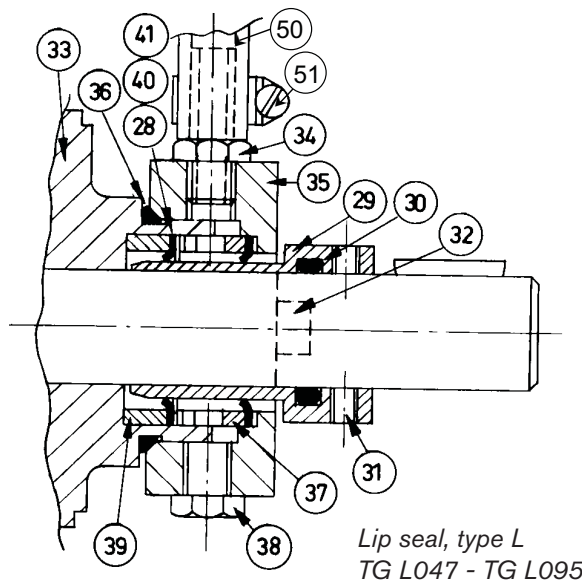

Lip seal, type L
TG L047 - TG L095

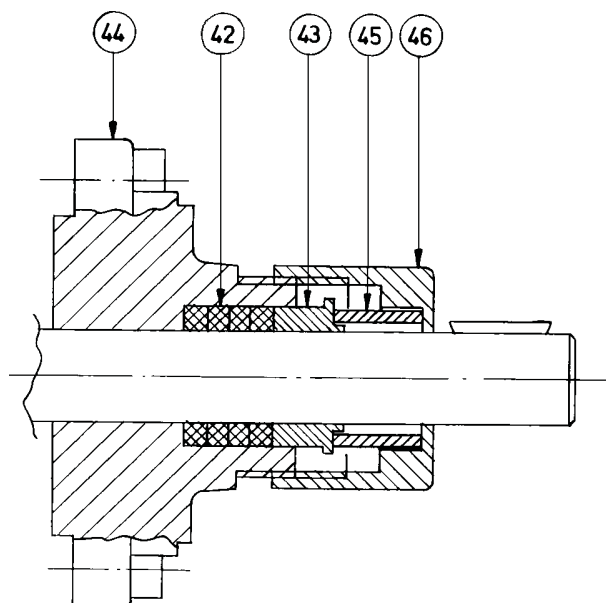

Gland packing, type R
TG L002 - TG L018

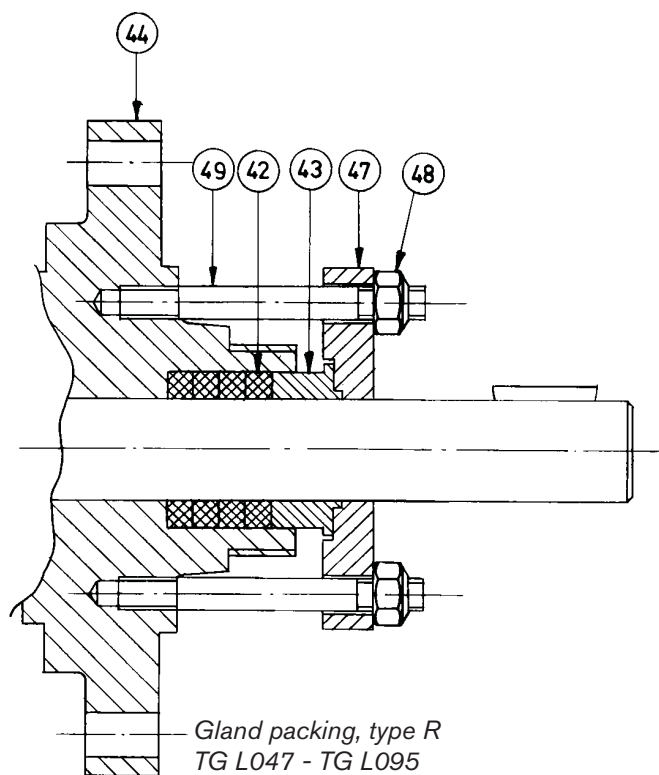

Gland packing, type R
TG L047 - TG L095

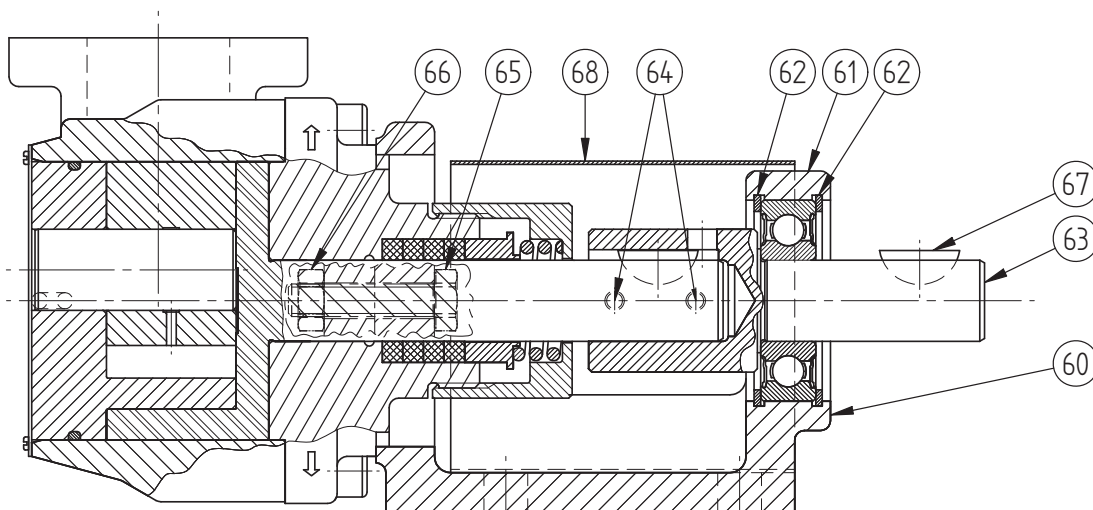

Gland packing, type FK (for belt drive) - Only for TG L095-03

6.2 Built-on safety relief valves

Pos	Description	Qty.
22	Screw	8
23	Gasket	4
70	Valve casing	1
71	Piston	1
72	Spring 0.5 - 3 bar	1
72	Spring 1 - 15 bar	1
72	Spring 13 - 25 bar	1

Pos	Description	Qty.
72	Spring 20 - 30 bar	1
73	Plunger	1
74	Screw	1
75	Sealing ring	1
76	Threaded rod insert	1
77	Nut	1
78	Cover	1

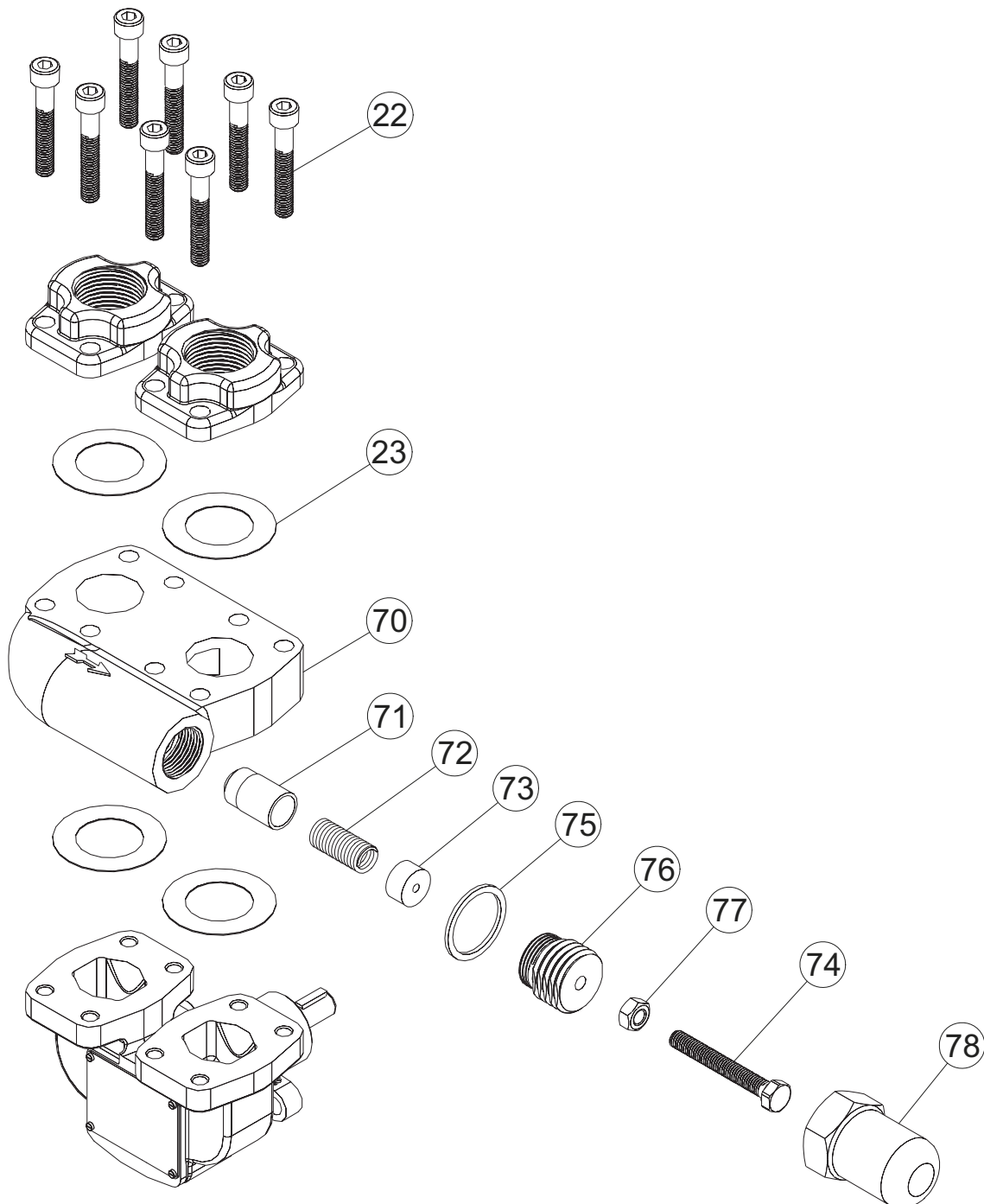

6.3 Separate safety relief valves - discontinued

Valves with 1/2" and 1" connections

Pos	Description	Qty.
71	Piston	1
72	Spring 0.5 - 3 bar	1
72	Spring 1 - 15 bar	1
72	Spring 13 - 25 bar	1
72	Spring 20 - 30 bar	1
73	Plunger	1
74	Screw	-
75	Sealing ring	-
76	Threaded rod insert	-
77	Nut	-
78	Cover	-
79	Valve casing	-

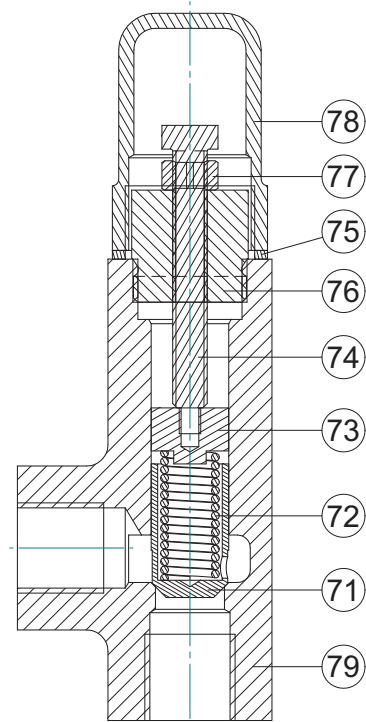

N.B. 1/2" and 1" valves are discontinued.

Valves with 2" connections

Pos	Description	Qty.
71	Piston	1
72	Spring 0.5 - 3 bar	1
72	Spring 1 - 7 bar	1
73	Plunger	1
74	Screw	-
75	Gasket	-
76	Cover	-
77	Washer	-
78	Plug	-

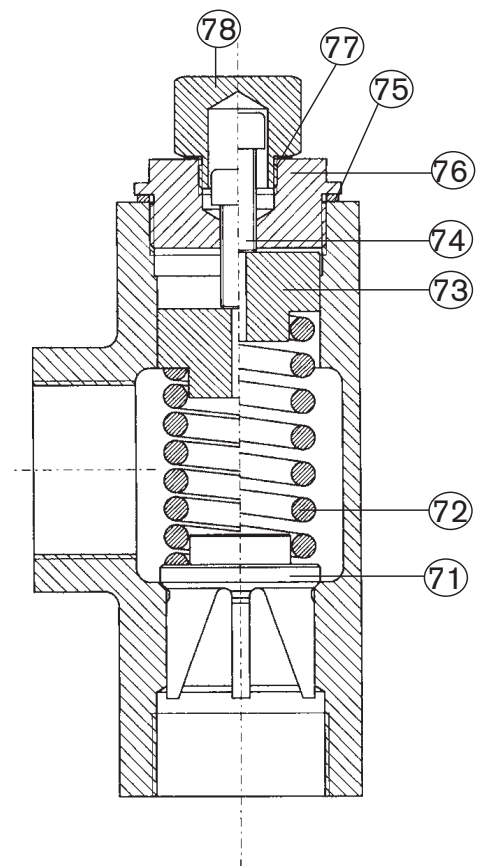

N.B. 2" valve is discontinued.

6.4 Counter pipe flange sets

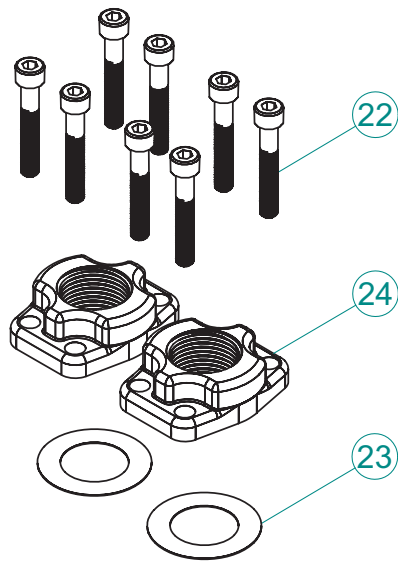

Threaded flange set

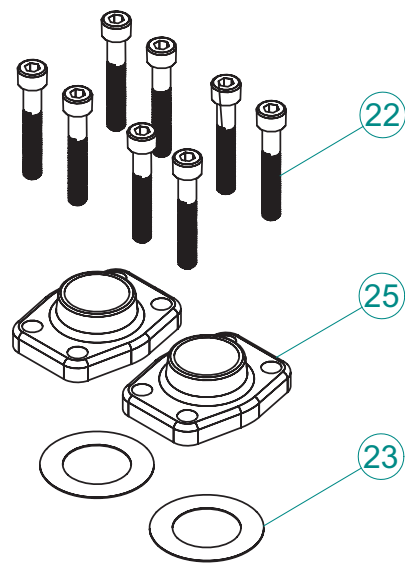

Flange set for welding

Pos.	Description	Qty		
		TG L002-004	TG L009-018	TG L047-095
Threaded flange set				
22	Screw	8	8	8
23	Gasket	2	2	2
24	Threaded pipe flange	2	2	2
Flange set for welding				
22	Screw	8	8	8
23	Gasket	2	2	2
25	Welding flange	2	2	2

6.5 Motor pedestal sets

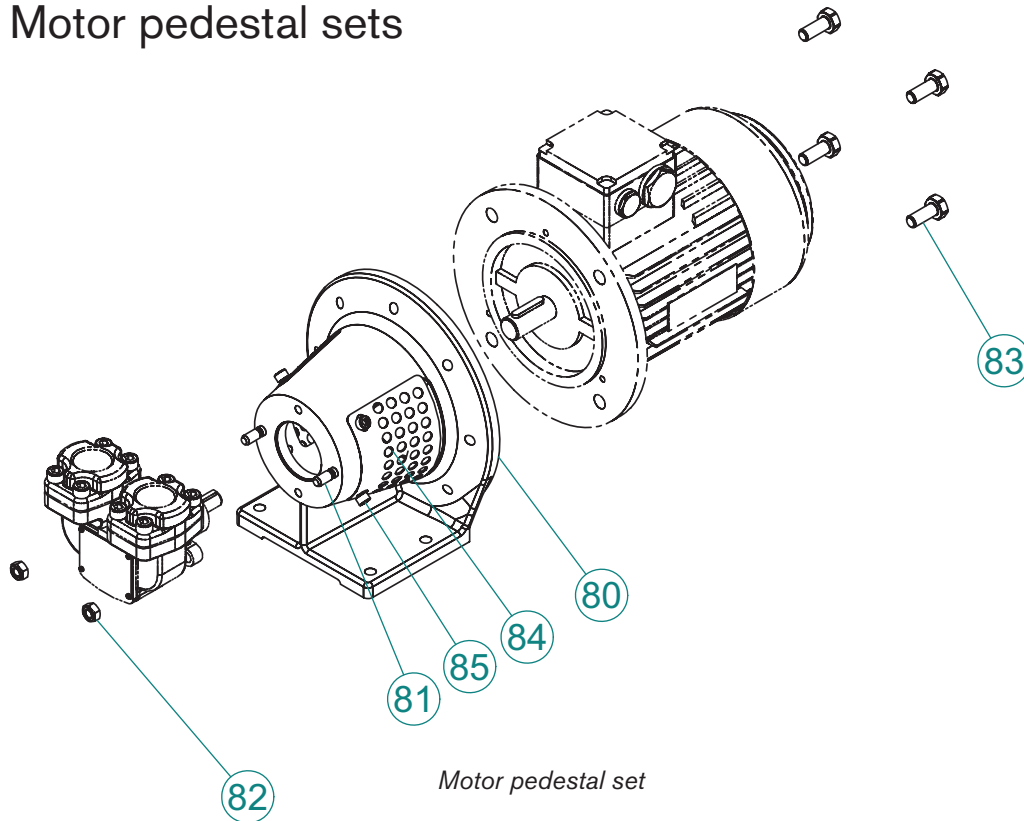

Pump	Pos.	Description	Qty			
			TG L002-004	TG L009-018	TG L047-095	
All (except 02L)	For motors IEC71					
	80	Flange pedestal	1	1	-	
	81	Stud bolt	2	2	-	
	82	Nut	2	2	-	
	83	Tap bolt	4	4	-	
	84	Mesh guard	2	2	-	
	85	Cap head screw	4	4	-	
	For motors IEC80/90					
	80	Flange pedestal	1	1	1	
	81	Stud bolt	2	2	2	
	82	Nut	2	2	2	
	83	Tap bolt	4	4	4	
	84	Mesh guard	2	2	2	
	85	Cap head screw	4	4	4	
	For motors IEC100/112					
	80	Flange pedestal	-	1	1	
	81	Stud bolt	-	2	2	
	82	Nut	-	2	2	
	83	Tap bolt	-	4	4	
	84	Mesh guard	-	2	2	
	85	Cap head screw	-	4	4	
	For motors IEC132					
	80	Flange pedestal	-	-	1	
	81	Stud bolt	-	-	2	
	82	Nut	-	-	2	
	83	Tap bolt	-	-	4	
	84	Mesh guard	-	-	2	
	85	Cap head screw	-	-	4	
For motors IEC100/112 B14 flange						
80	Flange pedestal	-	-	1		
81	Stud bolt	-	-	2		
82	Nut	-	-	2		
83	Tap bolt	-	-	4		
84	Mesh guard	-	-	2		
85	Cap head screw	-	-	4		

For 02L see next page

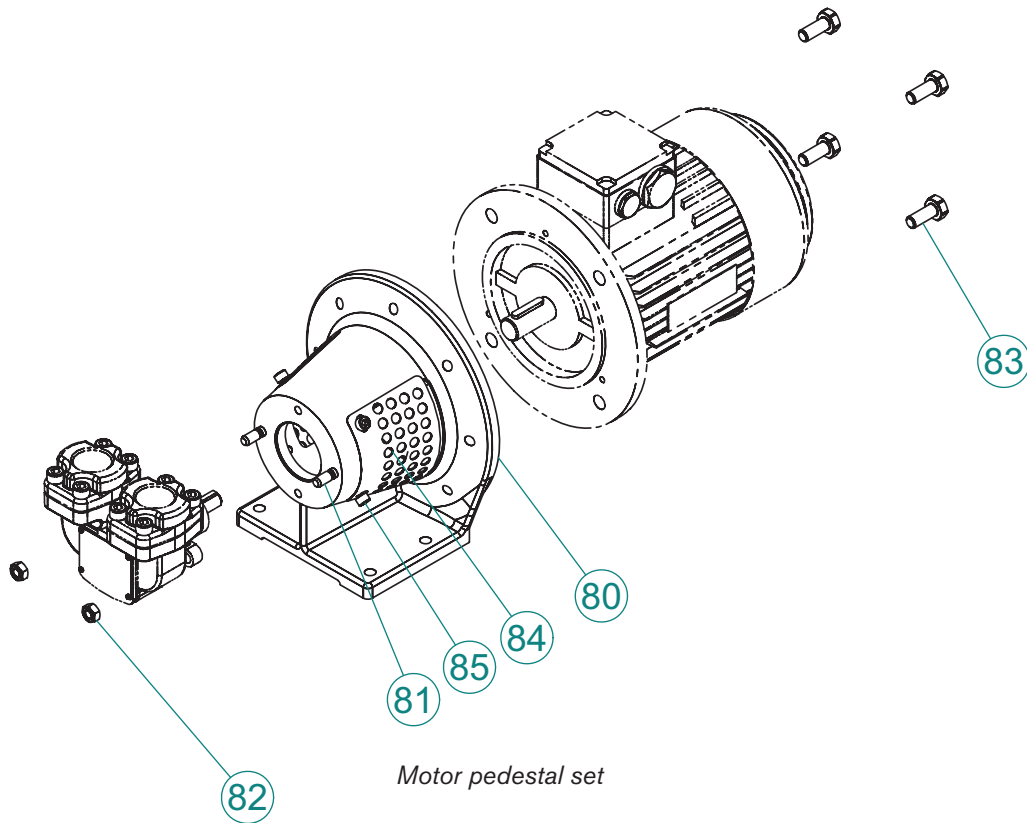

Pump	Pos.	Description	Qty			
			TG L002-004	TG L009-018	TG L047-095	
02L	For motors IEC71					
	80	Flange pedestal	1	1	-	
	81	Stud bolt	2	2	-	
	82	Nut	2	2	-	
	83	Tap bolt	4	4	-	
	84	Mesh guard	2	2	-	
	85	Cap head screw	4	4	-	
	For motors IEC80/90					
	80	Flange pedestal	1	1	1	
	81	Stud bolt	2	2	2	
	82	Nut	2	2	2	
	83	Tap bolt	4	4	4	
	84	Mesh guard	2	2	2	
	85	Cap head screw	4	4	4	
	For motors IEC100/112					
	80	Flange pedestal	-	1	1	
	81	Stud bolt	-	2	2	
	82	Nut	-	2	2	
	83	Tap bolt	-	4	4	
	84	Mesh guard	-	2	2	
	85	Cap head screw	-	4	4	
	For motors IEC132					
	80	Flange pedestal	-	-	1	
	81	Stud bolt	-	-	2	
	82	Nut	-	-	2	
83	Tap bolt	-	-	4		
84	Mesh guard	-	-	2		
85	Cap head screw	-	-	4		

6.6 Bracket sets

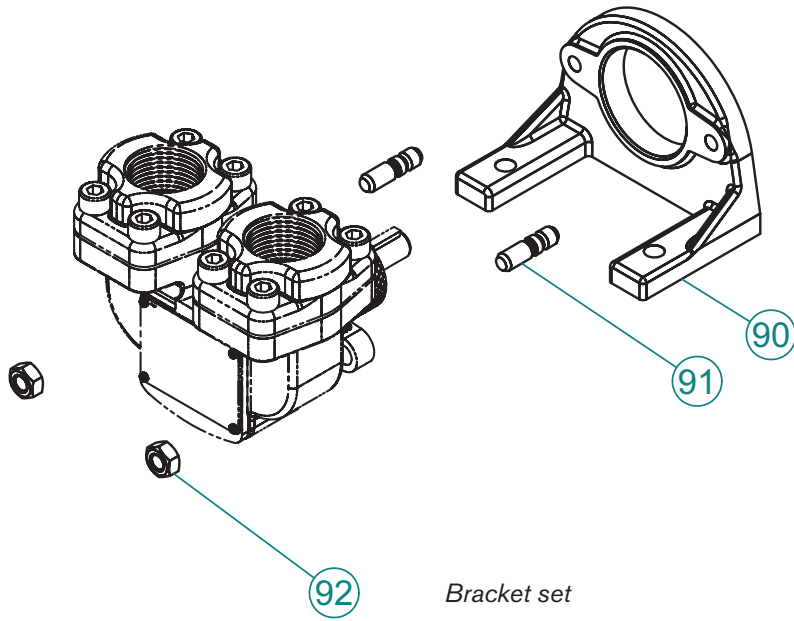

Pos.	Description	Qty		
		TG L002-004	TG L009-018	TG L047-095
Bracket set (except for 02L)				
90	Bracket	1	1	1
91	Stud bolt	2	2	2
92	Nut	2	2	2
Bracket set for 02L				
90	Bracket	1	1	1
91	Stud bolt	2	2	2
92	Nut	2	2	2

6.7 Shaft coupling sets

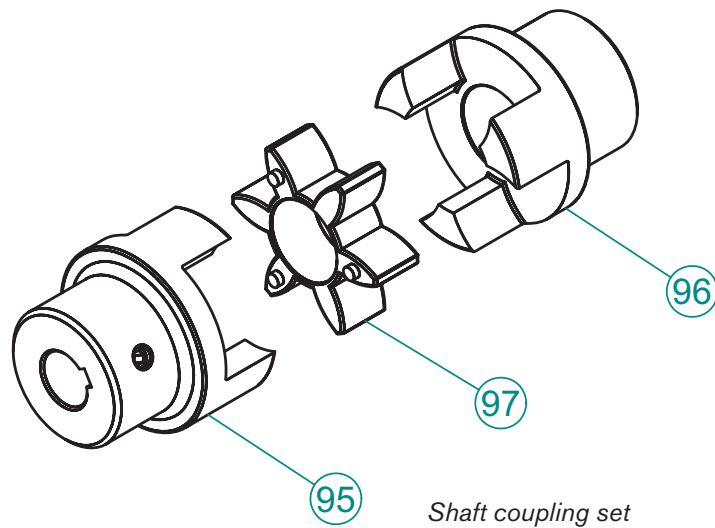

Pos.	Description	Qty		
		TG L002-004	TG L009-018	TG L047-095
For motor IEC71				
95	Coupling half	1	1	-
96	Coupling half	1	1	-
97	Spider for Rotex®	1	1	-
For motor IEC80				
95	Coupling half	1	1	1
96	Coupling half	1	1	1
97	Spider for Rotex®	1	1	1
For motor IEC90				
95	Coupling half	1	1	1
96	Coupling half	1	1	1
97	Spider for Rotex®	1	1	1
For motor IEC100/112				
95	Coupling half	-	1	1
96	Coupling half	-	1	1
97	Spider for Rotex®	-	1	1
For motor IEC132				
95	Coupling half	-	-	1
96	Coupling half	-	-	1
97	Spider for Rotex®	-	-	1

6.8 Packing and seal sets

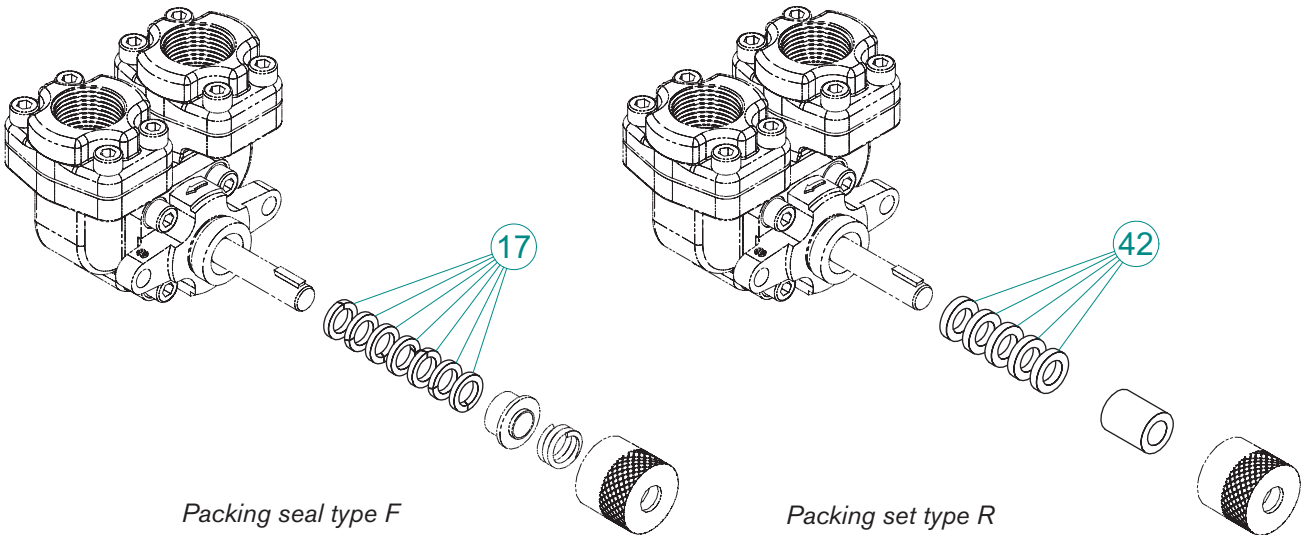

Pos.	Description	Qty		
		TG L002-004	TG L009-018	TG L047-095
Packing set type F^(*)				
17	Packing ring	6	4	4
Packing set type R^(*)				
42	Packing ring	6	5	4

^(*) new design

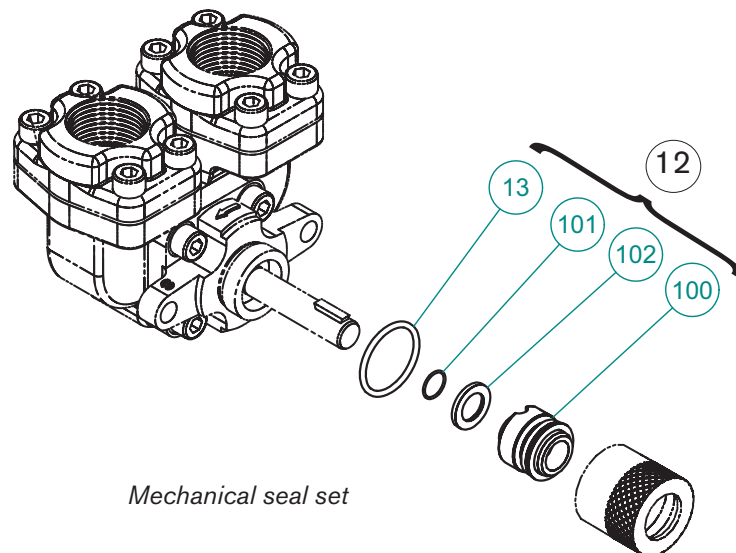

Pos.	Description	Qty		
		TG L002-004	TG L009-018	TG L047-095
12	Mechanical seal set type V			
100	Mechanical seal	1	1	1
101	Circlip	1	1	1
102	Support ring	1	1	1
13	O-ring	1	1	1

7.0 Dimensions and weights

7.1 TG L-pump

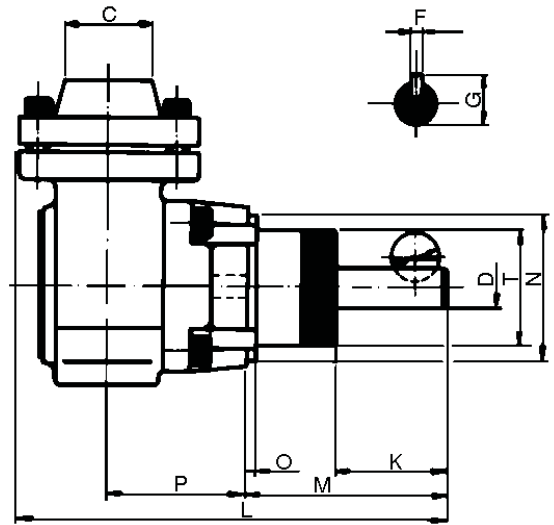
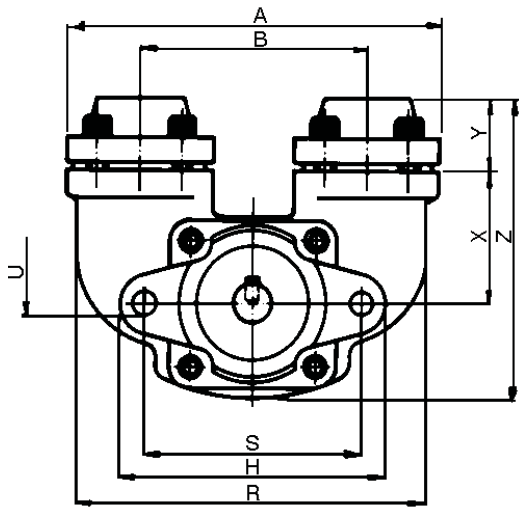

With bracket for foot mounting

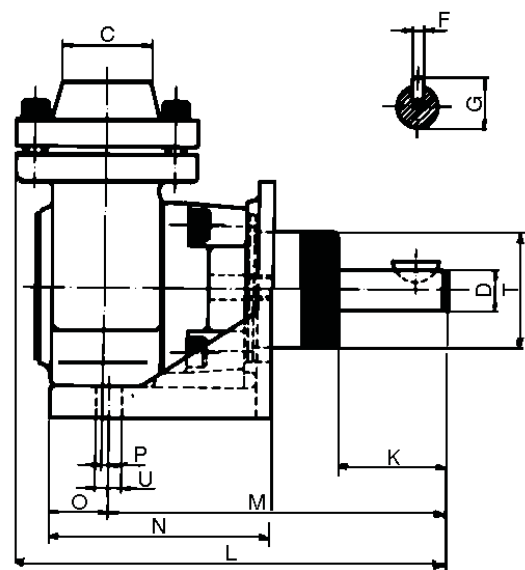
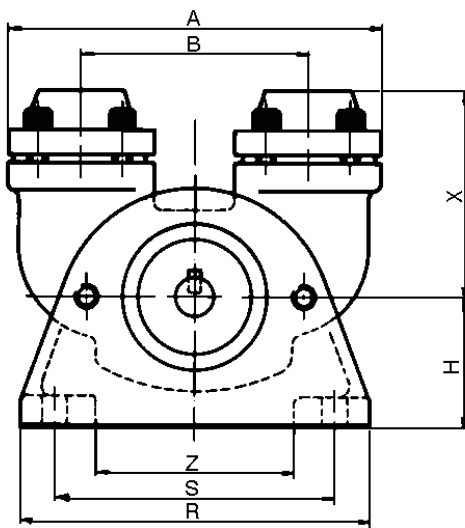

Dimensions in mm

Type	A	B	C	D ¹	F	G	H	K	L	M	N	O	P	R	S	T	U	X	Y	Z	Weight, kg
TG L002	123	68	30/ BSP1"	12	4	13,5	93	28	136	62	48	3	39	108	78	34	9,0	46	25	102	3,0
TG L004 *							44			98	67	18	3		85		8,5	71		68	
TG L009	162	98	38/ BSP1.1/4"	18	6	20,5	114	47	186	87	62	4	60	150	94	48	11,0	57	30	126	7,0
TG L018 *							56			145	98	25	2		120			87		86	
TG L047	205	128	44,5/ BSP1.1/2"	25	8	28,0	160	47	220	107	90	4	67	182	140	60	11,0	81	30	175	13,5
TG L095 *							65			169	115	34	5		150			13,5	111		125

¹ The following tolerances apply: ISO f6

* With bracket for foot mounting

7.2 Flanged pump unit

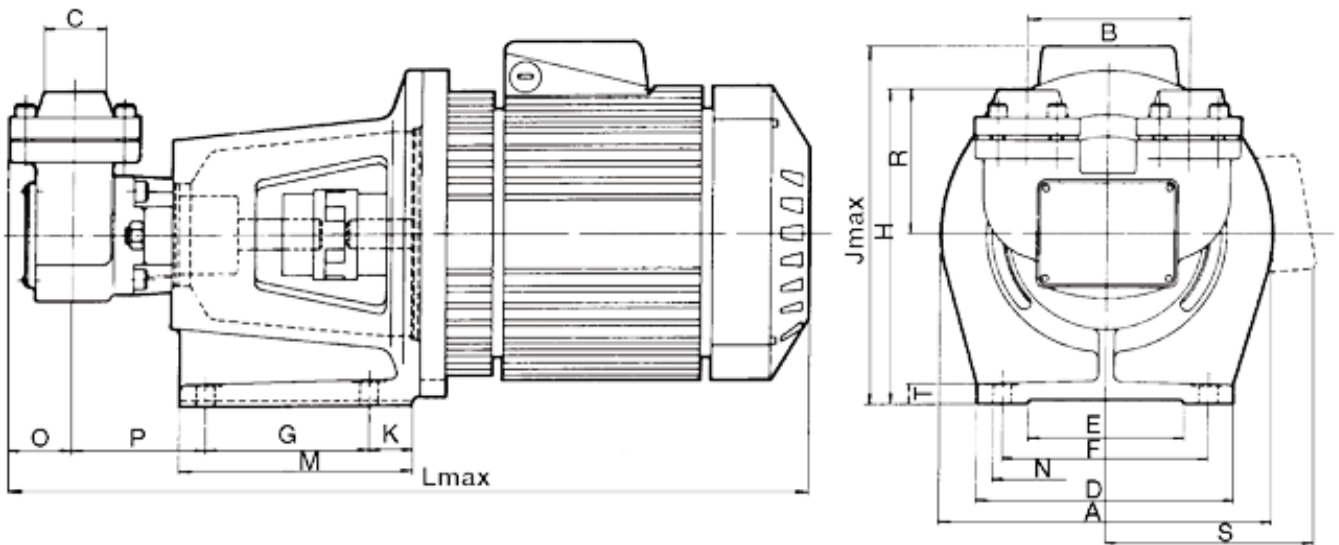

Dimensions in mm

Type	IEC	A	B	C	D	E	F	G	H*	J	K	L*	M	N	O*	P	R*	S	T	Weight, kg**	
TG L002	63									185		380						90			
TG L004	71	160	68	30/ BSP1"	145	85	120	60	156	205	25	400	100	9	35	57	71	120	15	7,5	21
	80	200													176	235	35	435	110		
TG L009	63			38/ BSP1.1/4"	145	85	120	60	172	205		430						90			
	71	160													235		450	110	9		100
TG L018	80	200	98	38/ BSP1.1/4"	170	110	140	100	192	25	25	520		40	80	87	130				
	90S																			240	
TG L018	90L			38/ BSP1.1/4"	210	140	180	100	217	305	60	630		11	80	87	150				
	100L																			280	
TG L047	90S			44,5/ BSP1.1/2"	200	130	170	120	231	255	40	570		11	87	111	135				
	90L	200																		280	
TG L095	100L		128	44,5/ BSP1.1/2"	230	160	200	120	241	305	50	680	185	11	87	111	175				
	112M	250																		725	
TG L095	132S			44,5/ BSP1.1/2"	230	160	200	120	273	362	60	770	200	11	87	111	175				
	132M	300																			

* With direct fitted safety relief valve the following measures are increased by:
 TG L002 - TG L004: H and R 26 mm, L and O 38 mm.
 TG L009 - TG L018: H and R 26 mm, L and O 46 mm.
 TG L047 - TG L095: H and R 30 mm, L and O 55 mm.

** Weight without motor and weight complete with standard motor in cast iron.

8.0 RBS4

8.1 General

The RBS4 pump is similar to the TG L018 as regard to capacity and size. All wetted parts are made of stainless steel AISI 316 and the rotor is journalled in a double ball bearing.

8.2 Type designation

Example:

RB	S	4	-	11	F	-	M1	-	00	-	T
1	2	3		4	5		6		7		8

1. Pump family name = RB

2. Materials

S = Stainless steel

3. Pump size = 4

4. Pump version

-01 = standard pump version, max. working temperature 60°C

-11 = pump version with ceramic idler bushing and hard metal idler pin,
max. working temperature 140°C

5. Shaft seals

S = single mechanical seal

F = spring loaded gland packing PTFE

6. Foot options

NF = no foot (with free shaft end)

BR = bracket for foot mounting (B3)

M1 = motor pedestal for B5-motor

7. Safety relief valve

00 = no relief valve

8. Counter pipe flanges

N = no counter pipe flanges

T = threaded flange set

8.11 Spare parts list

Pos	Version	Description	Qty.
1	01, 11	Pump casing	1
2	01	Pump cover complete	1
2	11	Pump cover complete	1
3	01, 11	Pump cover	1
4	01	Idler pin	1
4	11	Idler pin	1
5	01, 11	O-ring 49.5 x 3V	1
6	01, 11	Screw	4
7	01	Idler complete	1
7	11	Idler complete	1
7a	01, 11	Idler	1
7b	01	Idler bush	1
7b	11	Idler bush	2
8	01, 11 F, 01 S	Rotor	1
9	All	Key	1
10	All	Shim 0.013	x
10	All	Shim 0.025	x
10	All	Shim 0.05	x
10	All	Shim 0.10	x
11	01, 11 F	Interm. casing	1
11	01 S	Interm. casing	1
12	01, 11 F	Packing ring	5
12	01, 11 F	Mech. seal	1
13	All	O-ring 59.9 x 3V	1
14	01, 11 F	Support ring	1
14	01 S	Sleeve	1
15	All	Ball bearing 6203 DDU	2
16	01, 11 F	Distance sleeve	1
16	01 S	Distance sleeve	1
17	All	Locking washer	1
18	All	Locking nut,	1
19	All	Sealing ring	1
20	All	Bearing house	1
21	All	Screw	4
22	All	Screw	8
23	All	Gasket	2
24	All	Flange	2
25	All	Shim 0.05	x
25	All	Shim 0.076	x
25	All	Shim 0.20	x
26	All	Screw	2
27	01 S	Sealing ring	1
28	All	Name plate	1
29	All	Screw	2
30	01, 11 F	Support ring	2
31	01, 11 F	Spring	1
32	01, 11 F	Sleeve	1
33	01, 11 F	Sleeve	1
34	01, 11 F	O-ring 16.3 x 2.4V	1
36	All	Endcover	1
37	All	Screw	2

Pump with mechanical seal S

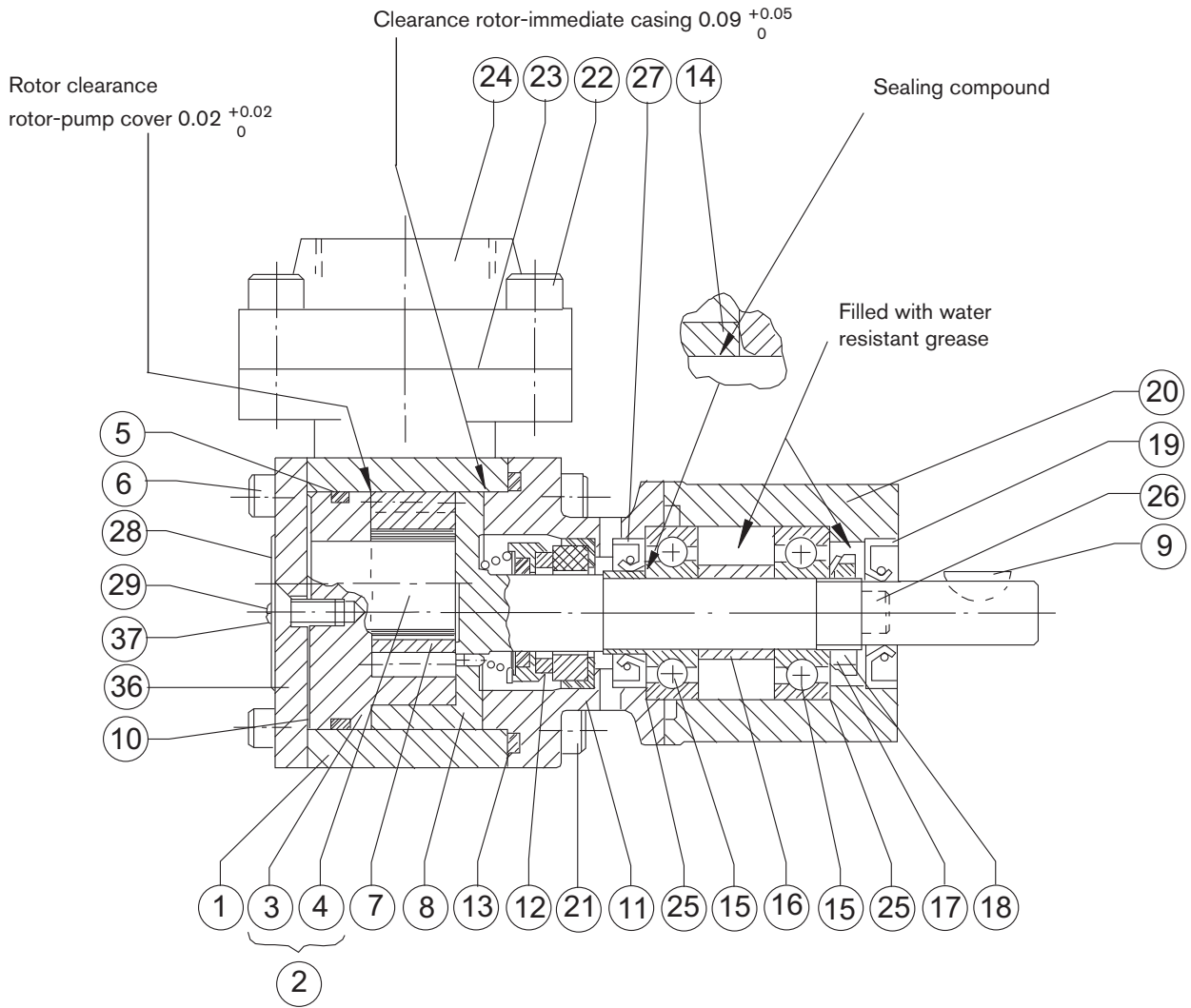

Pump with gland packing F

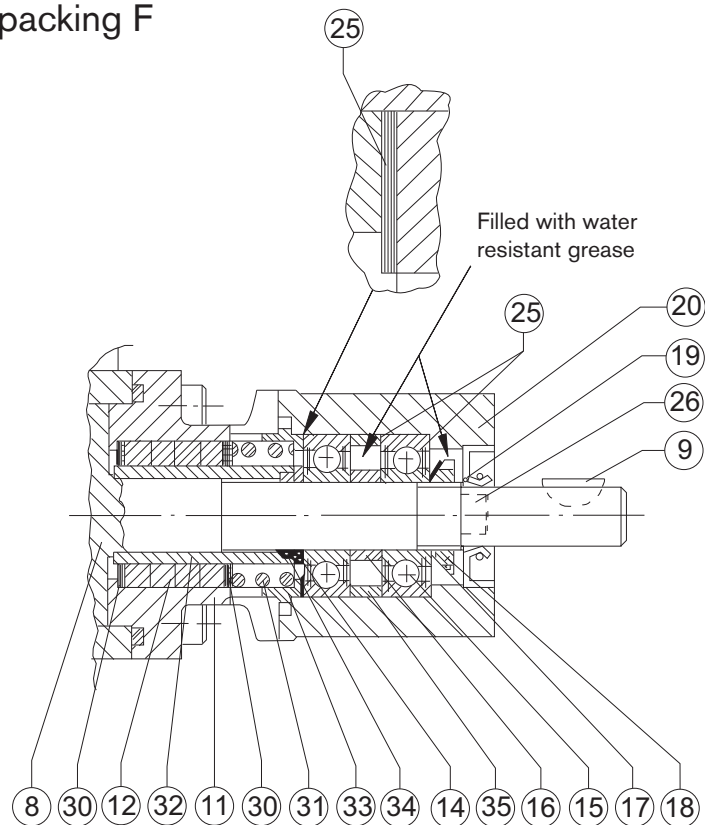

8.12 Counter pipe flange set

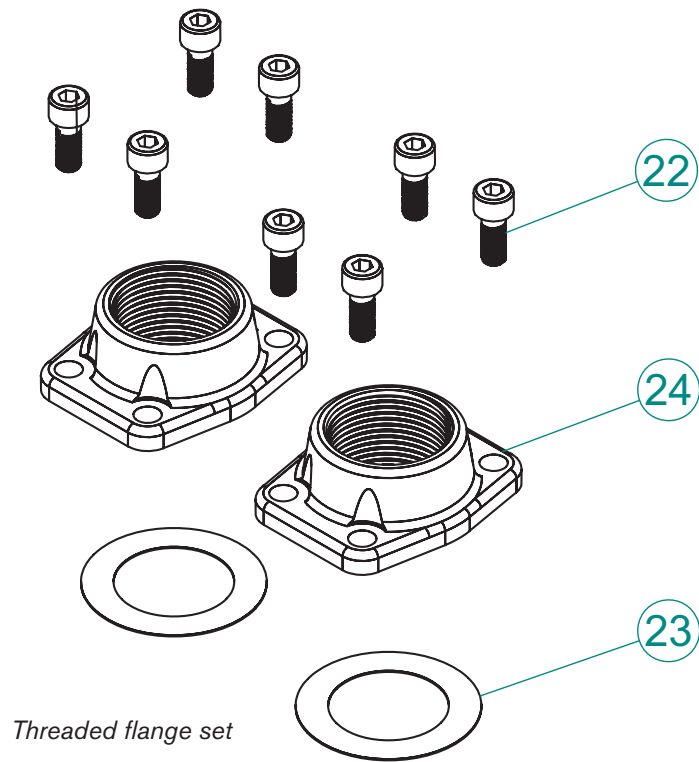

Pos.	Description	Qty
Threaded flange set		
22	Screw	8
23	Gasket	2
24	Threaded pipe flange	2

8.13 Motor pedestal sets

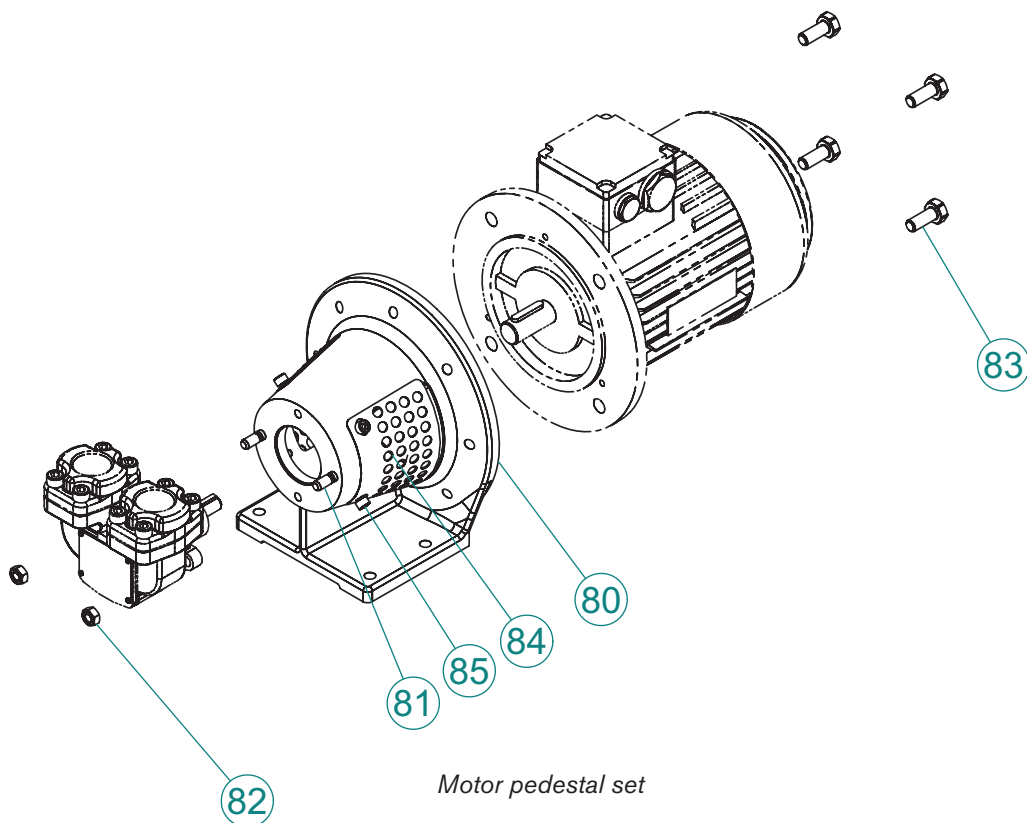

Pos.	Description	Qty
For motor IEC71		
80	Flange pedestal	1
81	Stud bolt	2
82	Nut	2
83	Tap bolt	4
84	Mesh guard	2
85	Cap head screw	4
For motor IEC80/90		
80	Flange pedestal	1
81	Stud bolt	2
82	Nut	2
83	Tap bolt	4
84	Mesh guard	2
85	Cap head screw	4
For motor IEC100/112		
80	Flange pedestal	1
81	Stud bolt	2
82	Nut	2
83	Tap bolt	4
84	Mesh guard	2
85	Cap head screw	4

8.14 Bracket set

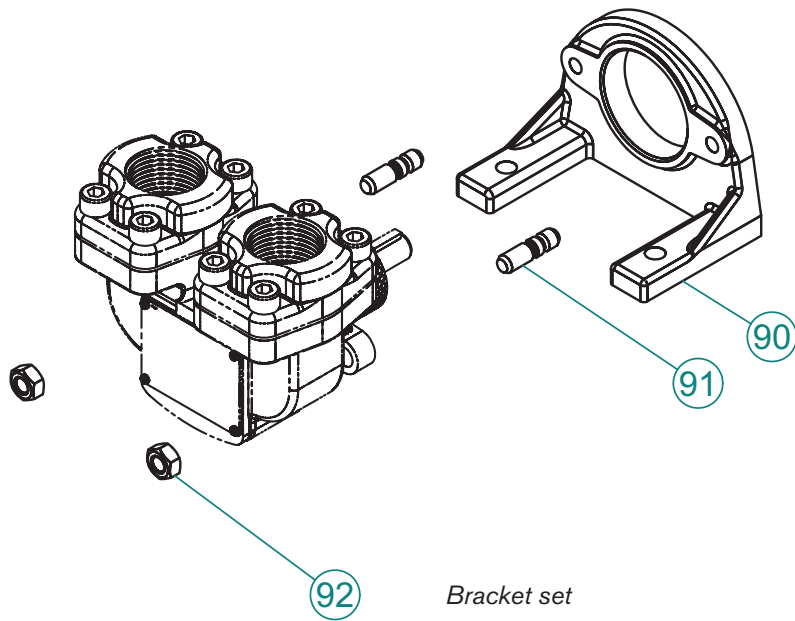

Pos.	Description	Qty
Bracket set		
90	Bracket	1
91	Stud bolt	2
92	Nut	2

8.15 Shaft coupling sets

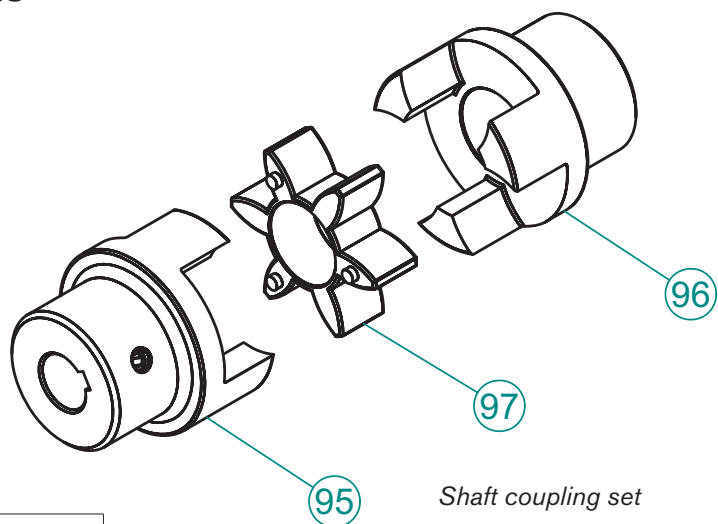

Pos.	Description	Qty
For motor IEC71		
95	Coupling half	1
96	Coupling half	1
97	Spider for Rotex®	1
For motor IEC80		
95	Coupling half	1
96	Coupling half	1
97	Spider for Rotex®	1
For motor IEC90		
95	Coupling half	1
96	Coupling half	1
97	Spider for Rotex®	1
For motor IEC100/112		
95	Coupling half	1
96	Coupling half	1
97	Spider for Rotex®	1

8.16 Packing and seal sets

See "8.11 Spare parts list" for drawings

Pos.	Description	Qty
Packing set, type F		
12	Packing ring	5

Pos.	Description	Qty
12	Mechanical seal set, type S	
100	Mechanical seal	1

8.17 Capacity for RBS4, water

For higher viscosities and for power calculations use the TG L018-diagram
(see chapter 3.0 Capacity)

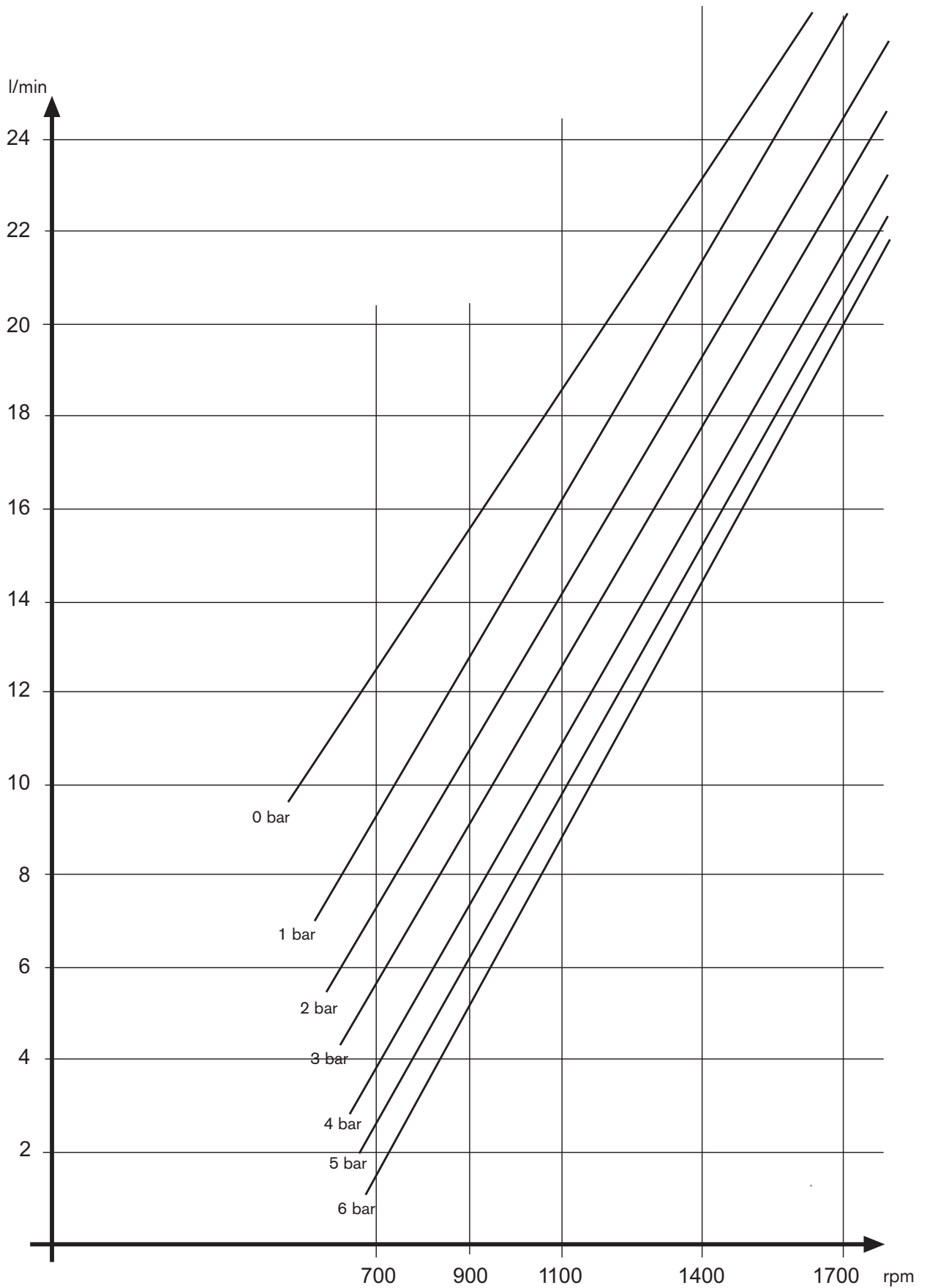

TopGear TG L/RBS-series

INTERNAL GEAR PUMPS

SPXFLOW

SPX FLOW TECHNOLOGY BELGIUM NV

Evenbroekveld 2-6

BE-9420 Erpe-Mere, Belgium

P: +32 (0)53 60 27 15

F: +32 (0)53 60 27 01

E: johnson-pump.be@spxflow.com

SPX reserves the right to incorporate our latest design and material changes without notice or obligation. Design features, materials of construction and dimensional data, as described in this bulletin, are provided for your information only and should not be relied upon unless confirmed in writing.

Please contact your local sales representative for product availability in your region. For more information visit www.spx.com.

ISSUED 11/2016 A.0100.201 EN

COPYRIGHT ©2005, 2008, 2009, 2010, 2011, 2013, 2015, 2016 SPX Corporation