



TECHNICAL SERVICE MANUAL

UNIVERSAL SEAL HEAVY DUTY PUMPS
 SERIES 124A/E/EH, 4124A, 224A/AH, AND 4224A/AH CAST IRON
 SERIES 126A, 4126A, 226A AND 4226A DUCTILE IRON
 SERIES 123A, 4123A, 223A AND 4223A STEEL
 SERIES 127A, 4127A, 227A AND 4227A STAINLESS STEEL
 SIZES LS, Q AND QS

SECTION	TSM 630.2
PAGE	1 OF 12
ISSUE	I

CONTENTS

Special Information	3
Maintenance	3
Disassembly	4
Assembly	5
Mechanical Seal Replacement	6
Seal Removal.	6
Seal Installation.	7
Thrust Bearing Adjustment	8
Installation of Carbon Graphite Bushings	9
Pressure Relief Valve Instructions	9
Disassembly	10
Assembly	10
Pressure Adjustment	10
Heat Cartridges	10

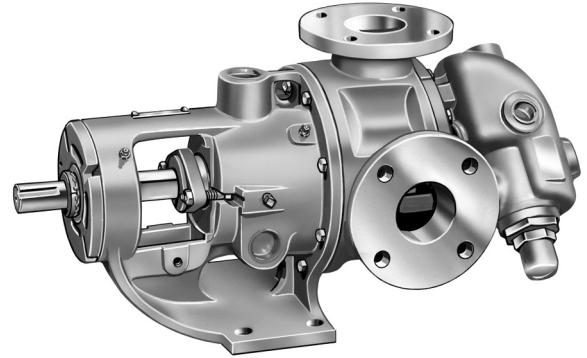

FIGURE 1
 Size LS illustrated
 (Shown with jacketed bracket and relief valve)

INTRODUCTION

The illustrations used in this manual are for identification purposes only and cannot be used for ordering parts. Obtain a parts list from the factory or a Viking representative. Always give a complete name of part, part number and material with the model number and serial number of pump when ordering repair parts. The unmounted pump or pump unit model number and serial number are on the nameplate.

In the Viking model number system, basic size letters are combined with series number (124A, 4124A, 124E, 124EH, 126A, 4126A, 123A, 4123A, 127A, 4127A, 224A, 224AH, 4224A, 4224AH, 226A, 4226A, 223A, 4223A, 227A, 4227A) indicating basic pump construction material.

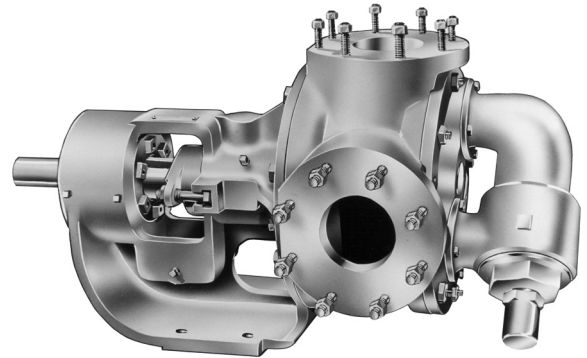

FIGURE 2
 Size Q illustrated
 (Non-Jacketed)

Model Chart Number

UNMOUNTED PUMP				UNITS
Non-Jacketed		Jacketed		
Packed	Mech. Seal	Packed	Mech. Seal	
LS124A	LS4124A	LS224A	LS4224A	Units are designated by the unmounted pump model numbers followed by a letter indicating drive style. V = V-Belt D = Direct Connected R = Viking Speed Reducer P = Commercial Speed Reducer
LS124E		LS224AH	LS224AH	
LS124EH	LS4126A	LS226A	LS4226A	
LS126A		LS223A	LS4223A	
LS123A	LS4123A	LS227A	LS4227A	
LS127A	LS4127A	Q224A	Q4224A	
Q124A	Q4124A	Q226A	Q4226A	
Q124E		Q223A	Q4223A	
Q126A	Q4126A	Q227A	Q4227A	
Q123A	Q4123A	QS226A	QS4226A	
Q127A	Q4127A	QS223A	QS4223A	
QS124A	QS4124A	QS227A	QS4227A	
QS124E				
QS126A	QS4126A			
QS123A	QS4123A			
QS127A	QS4127A			

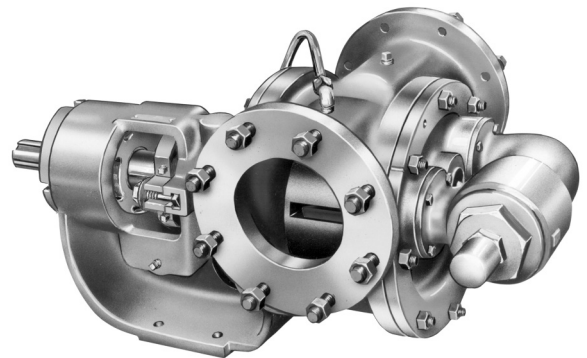

FIGURE 3
 Size QS illustrated
 (Non-Jacketed)

SAFETY INFORMATION AND INSTRUCTIONS

IMPROPER INSTALLATION, OPERATION OR MAINTENANCE OF PUMP MAY CAUSE SERIOUS INJURY OR DEATH AND/OR RESULT IN DAMAGE TO PUMP AND/OR OTHER EQUIPMENT. VIKING'S WARRANTY DOES NOT COVER FAILURE DUE TO IMPROPER INSTALLATION, OPERATION OR MAINTENANCE.

THIS INFORMATION MUST BE FULLY READ BEFORE BEGINNING INSTALLATION, OPERATION OR MAINTENANCE OF PUMP AND MUST BE KEPT WITH PUMP. PUMP MUST BE INSTALLED, OPERATED AND MAINTAINED ONLY BY SUITABLY TRAINED AND QUALIFIED PERSONS.

THE FOLLOWING SAFETY INSTRUCTIONS MUST BE FOLLOWED AND ADHERED TO AT ALL TIMES.

Symbol Legend :



Danger - Failure to follow the indicated instruction may result in serious injury or death.

WARNING

Warning - In addition to possible serious injury or death, failure to follow the indicated instruction may cause damage to pump and/or other equipment.



BEFORE opening any liquid chamber (pumping chamber, reservoir, relief valve adjusting cap fitting, etc.) be sure that :

- Any pressure in the chamber has been completely vented through the suction or discharge lines or other appropriate openings or connections.
- The pump drive system means (motor, turbine, engine, etc.) has been "locked out" or otherwise been made non-operational so that it cannot be started while work is being done on the pump.
- You know what material the pump has been handling, have obtained a material safety data sheet (MSDS) for the material, and understand and follow all precautions appropriate for the safe handling of the material.

WARNING

INSTALL pressure gauges/sensors next to the pump suction and discharge connections to monitor pressures.



WARNING

USE extreme caution when lifting the pump. Suitable lifting devices should be used when appropriate. Lifting eyes installed on the pump must be used **only** to lift the pump, **not** the pump with drive and/or base plate. If the pump is mounted on a base plate, the base plate must be used for all lifting purposes. If slings are used for lifting, they must be safely and securely attached. For weight of the pump alone (which does not include the drive and/or base plate) refer to the Viking Pump product catalog.



BEFORE operating the pump, be sure all drive guards are in place.



DO NOT attempt to dismantle a pressure relief valve that has not had the spring pressure relieved or is mounted on a pump that is operating.



DO NOT operate pump if the suction or discharge piping is not connected.



AVOID contact with hot areas of the pump and/or drive. Certain operating conditions, temperature control devices (jackets, heat-tracing, etc.), improper installation, improper operation, and improper maintenance can all cause high temperatures on the pump and/or drive.



DO NOT place fingers into the pumping chamber or its connection ports or into any part of the drive train if there is **any possibility** of the pump shafts being rotated.



WARNING

THE PUMP must be provided with pressure protection. This may be provided through a relief valve mounted directly on the pump, an in-line pressure relief valve, a torque limiting device, or a rupture disk. If pump rotation may be reversed during operation, pressure protection must be provided on **both** sides of pump. Relief valve adjusting screw caps must always point towards suction side of the pump. If pump rotation is reversed, position of the relief valve must be changed. Pressure relief valves cannot be used to control pump flow or regulate discharge pressure. For additional information, refer to Viking Pump's Technical Service Manual TSM 000 and Engineering Service Bulletin ESB-31.

WARNING

DO NOT exceed the pumps rated pressure, speed, and temperature, or change the system/duty parameters from those the pump was originally supplied, without confirming its suitability for the new service.



WARNING

BEFORE operating the pump, be sure that:

- It is clean and free from debris
- all valves in the suction and discharge pipelines are fully opened.
- All piping connected to the pump is fully supported and correctly aligned with the pump.
- Pump rotation is correct for the desired direction of flow.



WARNING

THE PUMP must be installed in a matter that allows safe access for routine maintenance and for inspection during operation to check for leakage and monitor pump operation.

This manual deals only with Series 124A, 4124A, 124E, 124EH, 126A, 4126A, 123A, 4123A, 127A, 4127A, 224A, 224AH, 4224A, 4224AH, 226A, 4226A, 223A, 4223A, 227A and 4227A Heavy Duty Bracket Mounted Pumps. **Refer to Figures 1 through 13** for general configuration and nomenclature used in this manual. Pump specifications and recommendations are listed in Catalog Section 630, Heavy Duty Bracket Mounted Pumps, with Universal Seal Type Bracket.

SPECIAL INFORMATION

DANGER !

Before opening any Viking pump liquid chamber (pumping chamber, reservoir, relief valve adjusting cap fitting, etc.) Be sure:

- 1. That any pressure in the chamber has been completely vented through the suction or discharge lines or other appropriate openings or connections.**
- 2. That the driving means (motor, turbine, engine, etc.) has been “locked out” or made non-operational so that it cannot be started while work is being done on pump.**
- 3. That you know what liquid the pump has been handling and the precautions necessary to safely handle the liquid. Obtain a material safety data sheet (MSDS) for the liquid to be sure these precautions are understood.**

Failure to follow above listed precautionary measures may result in serious injury or death.

ROTATION: Viking pumps operate equally well in a clockwise or counterclockwise rotation. Shaft rotation determines which port is suction and which is discharge. Port in area where pumping elements (gear teeth) come out of mesh is suction port.

PRESSURE RELIEF VALVES:

- Viking pumps are positive displacement pumps and must be provided with some sort of pressure protection. This may be a relief valve mounted directly on the pump, an inline pressure relief valve, a torque limiting device or a rupture disk.
- There are relief valve options available on those pump models designed to accept a relief valve. Options may include a return to tank relief valve and a jacketed relief valve. Pumps equipped with a jacketed head plate are generally not available with a relief valve.
- If pump rotation is reversed during operation, pressure protection must be provided on **both** sides of pump.
- Relief valve adjusting screw cap must **always** point towards suction side of pump. If pump rotation is

reversed, remove pressure relief valve and turn end for end.

- Pressure relief valves cannot be used to control pump flow or regulate discharge pressure.

For additional information on pressure relief valves, **Refer to Technical Service Manual TSM000 and Engineering Service Bulletin ESB-31.**

SPECIAL MECHANICAL SEALS:

Extra care should be taken in repair of these pumps. Be sure to read and follow all special instructions supplied with your pump.

MAINTENANCE

Viking pumps are designed for long, trouble-free service life under a wide variety of application conditions with a minimum of maintenance. The points listed below will help provide long service life.

LUBRICATION: External lubrication must be applied slowly with a hand gun to all lubrication fittings every 500 hours of operation with multi-purpose grease, NLGI # 2. **Refer to Engineering Service Bulletin ESB-515.** Consult factory with specific lubrication questions. Applications involving very high or low temperatures will require other types of lubrication.

PACKING ADJUSTMENT: New packed pumps require initial packing adjustment to control leakage as packing “runs in”. Make initial adjustments carefully and do not over-tighten packing gland. After initial adjustment, inspection will reveal need for packing replacement. **Refer to instructions under Assembly on page 5,** regarding repacking pump.

CLEANING PUMP: Keep pump as clean as possible. This will facilitate inspection, adjustment and repair work and help prevent overlooking a dirt covered grease fitting.

STORAGE: If pump is to be stored, or not used for six months or more, pump must be drained and a light coat of light oil must be applied to all internal pump parts.

Lubricate fittings and apply grease to pump shaft extension. Viking suggests rotating pump shaft by hand one complete revolution every 30 days to circulate the oil.

SUGGESTED REPAIR TOOLS: The following tools must be available to properly repair Universal Seal Bracket Pumps. These tools are in addition to standard mechanics’ tools such as open-end wrenches, pliers, screwdrivers, etc. Most of the items can be obtained from an industrial supply house.

- Soft Headed hammer
- Allen wrenches (some mechanical seals and set collars)
- Packing hooks, flexible (packed pumps)
- Mechanical seal installation sleeve
2-751-005-630 for 2.4375 inch seal; Q-QS pumps.
- Bearing locknut spanner wrench
(Source: #472 J. H. Williams & Co. or equal);
LS-QS pumps.
- Spanner wrench, adjustable pin type for use on bearing housing (Source: #482 J. H. Williams & Co. or equal)
- Brass bar
- Arbor press

DISASSEMBLY

DANGER !

Before opening any Viking pump liquid chamber (pumping chamber, reservoir, relief valve adjusting cap fitting, etc.)

Be sure:

1. That any pressure in the chamber has been completely vented through the suction or discharge lines or other appropriate openings or connections.
2. That the driving means (motor, turbine, engine, etc.) has been "locked out" or made non-operational so that it cannot be started while work is being done on pump.
3. That you know what liquid the pump has been handling and the precautions necessary to safely handle the liquid. Obtain a material safety data sheet (MSDS) for the liquid to be sure these precautions are understood.

Failure to follow above listed precautionary measures may result in serious injury or death.

1. Mark head and casing before disassembly to insure proper reassembly. The idler pin, which is offset in pump head, must be positioned toward and equal distance between port connections to allow for proper flow of liquid through the pump.

Remove head from pump. Do not allow idler to fall from idler pin. Tilt top of head back when removing to prevent this. Avoid damaging head gasket. If pump is furnished with pressure relief valve, it need not be removed from head or disassembled at this point. **Refer to Pressure Relief Valve Instructions, page 9.**

If pump has jacketed head plate, it will separate from head when it is removed. The gasket between head and jacket head plate must be totally removed. Use new gasket when assembling pump.

2. Remove idler and bushing assembly.
3. Insert length of hardwood or brass through port opening between rotor teeth or lock coupling end or shaft to keep shaft from turning. Bend up tang of lockwasher and with a spanner wrench; remove locknut and lockwasher from shaft.
4. Loosen two setscrews in the face of the bearing housing and remove the bearing housing assembly from the bracket. **Refer to Figure 5 or 6, page 5.**
5. Remove pair of half round rings under the inner spacer collar from the shaft. **NOTE:** There are no half round rings on "Q" and "QS" size pumps.
6. Remove packing gland capscrews, slide-packing gland out of stuffing box, and remove packing.

NOTE: Reference **Mechanical Seal Replacement** beginning on **page 6** when disassembling seal pump.

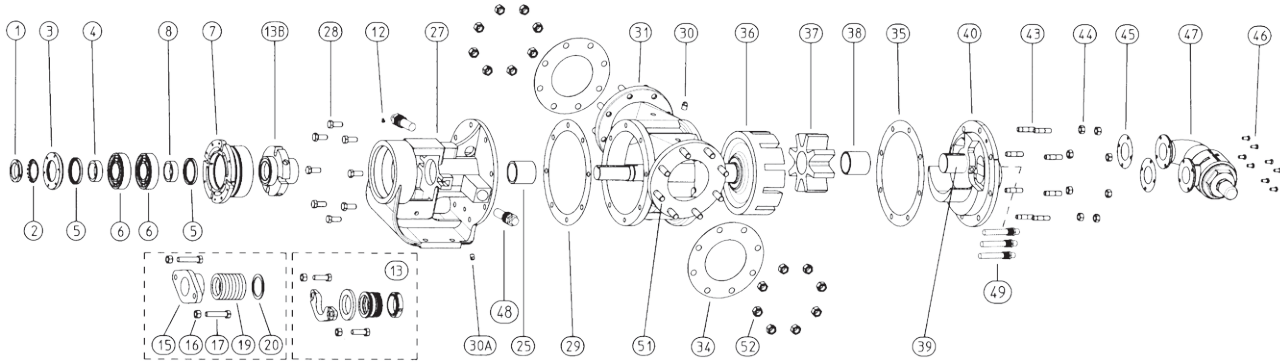

ITEM	NAME OF PART	ITEM	NAME OF PART	ITEM	NAME OF PART
1	Locknut	17	Packing Gland Capscrew	39	Idler Pin
2	Lockwasher	19	Packing	40	Head and Pin Assembly
3	End Cap for Bearing Housing	25	Bracket Bushing	43	Stud for Head
4	Bearing Spacer Collar (Outer)	27	Bracket and Bushing Assembly	44	Nut for Head
5	Lip Seal for Bearing Housing (2 Req'd)	28	Capscrew for Bracket	45	Relief Valve Gasket
6	Roller Bearing (2 Req'd)	29	Bracket Gasket	46	Capscrew for Relief Valve
7	Bearing Housing	30	Pipe Plug	47	Internal Relief Valve
8	Bearing Spacer Collar (Inner)	31	Casing	48	Heater Cartridges for Bracket (124E Pumps Only)
12	Grease Fitting	34	Pipe Flange Gasket	49*	Heater Cartridges for Head (124E Pumps Only)
13	Mechanical Seal	35	Head Gasket	51	Stud for Flanges
13B	Cartridge Mechanical Seal	36	Rotor and Shaft Assembly	52	Nut for Flanges
15	Packing Gland	37	Idler and Bushing Assembly	Not Illus.	Cover Plate, Relief Valve
16	Packing Gland Nut	38	Idler Bushing		

FIGURE 4
EXPLODED VIEW OF UNIVERSAL BRACKET PUMP (TYPICAL)

* The number of Heater Cartridges for Head varies by pump size. See Table 2 on Page 13 for the number required by pump size.

7. Carefully remove rotor and shaft to avoid damaging bracket bushing.
8. Loosen two radial setscrews in flange of bearing housing and with a spanner wrench remove the outer end cap with closure and outer bearing spacer collar.
9. Remove the double row ball bearing, (2 tapered roller bearings on "Q" and "QS" sizes), closure and inner bearing spacer collar from the bearing housing.
10. Clean all parts thoroughly and examine for wear and damage. Check lip seals, bearings, bushings, and idler pin and replace if necessary. Check all other parts for nicks, burrs, excessive wear and replace if necessary. Wash bearings in clean solvent. Blow out bearings with compressed air. Do not allow bearings to spin; turn them slowly by hand. Spinning bearings will damage bearing components. Make sure bearings are clean, then lubricate with light oil and check for roughness. Roughness can be determined by turning outer race by hand.

CAUTION: Do not intermix inner and outer races of tapered roller bearing ("Q" and "QS" sizes).

11. Casing can be checked for wear or damage while mounted on bracket.
12. Inspect bracket bushing for wear and remove if damaged or worn.

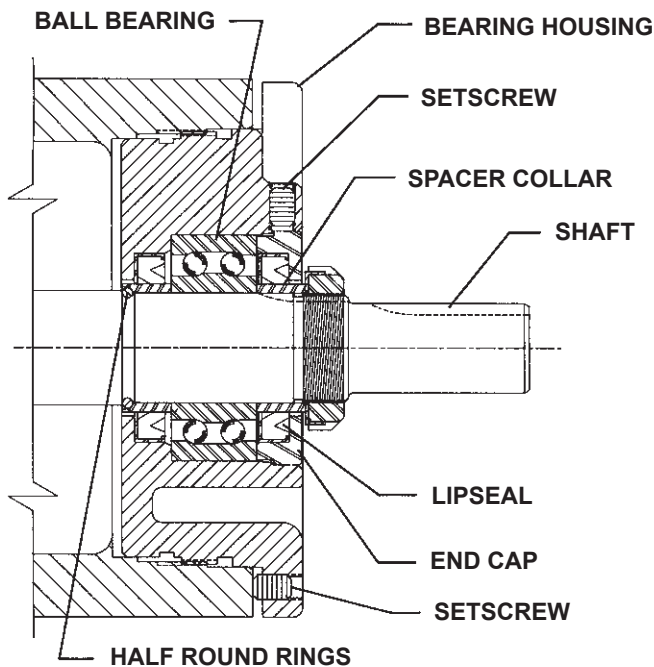

FIGURE 5
LS BEARING HOUSING ASSEMBLY

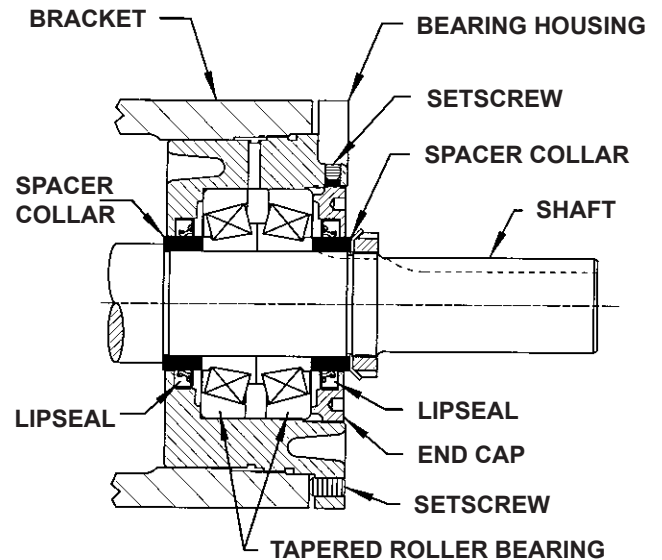

FIGURE 6
Q-QS BEARING HOUSING ASSEMBLY

ASSEMBLY

1. Install bracket bushing. If bracket bushing has a lubrication groove, install bushing with groove at 6.00 o'clock position in bracket. If carbon graphite, **Refer to Installation of Carbon Graphite Bushings, page 9.**
2. Coat shaft of rotor shaft assembly with light oil. Start end of shaft in bracket bushing turning from right to left, slowly pushing rotor in casing.
3. Coat idler pin with light oil and place idler and bushing on idler pin in head. If replacing with carbon graphite bushing, **Refer to Installation of Carbon Graphite Bushings, page 9.**
4. Using a .010 to .015 inch thick head gasket, install head and idler assembly on pump. Pump head and casing should have been marked before disassembly to insure proper reassembly. If not, be sure idler pin, which is offset in pump head, is positioned toward the equal distance between port connections to allow for proper flow of liquid through pump.

Refer to Figure 5 and 6 for bearing housing assembly.

5. Install the lipseal in the bearing housing (**See the appropriate figure for lip orientation**).
6. **"LS" Pumps:** Pack the ball bearing with grease and push or press the bearing into the bearing housing. **Refer to Figure 5.**
"Q" and "QS" Pumps: Pack tapered roller bearings with grease and press or push bearings into housing with large end of inner races together. It is possible to install bearings incorrectly. For proper assembly see Figure 6.
7. Install the lipseal in the end cap (see appropriate figure for lip orientation). Thread the end cap into the bearing housing along with outer bearing spacer collar and tighten against the bearing.

“Q” and “QS” PUMPS ONLY: Tapered roller bearings require preload to operate properly. To set preload tighten end cap so that inner races of bearings cannot be rotated by hand. Back the end cap off to allow inner races to rotate with slight resistance.

Lock end cap in place with two setscrews in the flange of the bearing housing.

8. When assembling pack pump, use packing suitable for liquid being pumped. Install packing, staggering the joints from one side of shaft to other. Lubricate packing rings with oil, grease, or graphite to aid assembly. Install packing, capscrews, and nuts. Make sure gland is installed square and nuts are tightened evenly. Tighten nuts until packing gland is snug against packing.

NOTE: See **Seal Installation, page 7** when re-assembling a seal pump.

9. Slide inner spacer collar over shaft with recessed end facing rotor. “Q” and “QS” bearing spacer collars are not recessed.

Place pair of half round rings on shaft and slide inner bearing spacer collar over half round rings to lock them in place. There is no pair of half round rings on “Q” and “QS” size pumps.

10. Thread the bearing housing with lipseals; end cap, outer bearing spacer collar and bearings installed into bracket.
11. Put lockwasher and locknut on shaft. Insert length of hardwood or brass through port opening between rotor teeth to keep shaft from turning. Tighten locknut to 120-150 - ft.lbs. torque (LS) or 170-190 - ft.lbs. torque (Q,QS) . If tang does not line up with slot, tighten locknut until it does. Failure to tighten locknut or engage lockwasher tang could result in early bearing failure and cause damage to rest of pump. Remove length of hardwood or brass from port opening.
12. Adjust pump end clearance as in **Thrust Bearing Adjustment page 8**.
13. Lubricate all grease fittings with multi-purpose grease, NLGI #2.

DANGER !

Before starting pump, be sure all drive equipment guards are in place.

Failure to properly mount guards may result in serious injury or death.

MECHANICAL SEAL REPLACEMENT

This manual deals with the three standard types of mechanical seals supplied on Universal Bracket models 4124A, 4126A, 4123A, 4127A, 4224A, 4224AH, 4226A, 4223A, 4227A.

1. Cartridge (**Figure 7, page 7**)
2. Elastomeric Bellows (**Figure 9, page 7**)
3. PTFE Wedge (**Figure 10, page 7**)

Identification of seal type is an important step towards proper maintenance. For mechanical seal types not shown, see the Seal Instruction Drawing (SID) furnished with the pump or contact a Viking representative.

SEAL REMOVAL

DANGER !

Before opening any Viking pump liquid chamber (pumping chamber, reservoir, relief valve adjusting cap fitting, etc.) Be sure:

1. **That any pressure in the chamber has been completely vented through the suction or discharge lines or other appropriate openings or connections.**
2. **That the driving means (motor, turbine, engine, etc.) has been “locked out” or made non-operational so that it cannot be started while work is being done on pump.**
3. **That you know what liquid the pump has been handling and the precautions necessary to safely handle the liquid. Obtain a material safety data sheet (MSDS) for the liquid to be sure these precautions are understood.**

Failure to follow above listed precautionary measures may result in serious injury or death.

CARTRIDGE TYPE

Cartridge mechanical seals are designed so that they may be replaced with minimal pump and piping disassembly. The seal may be accessed by removing the bearing housing. (**See Disassembly, Steps 3-5, page 4**).

1. Remove any flush or barrier fluid tubes connected to the seal gland.
2. Loosen setscrews on the seal collar to free the cartridge seal from the shaft.
3. Remove the two gland capscrews and slide the cartridge seal out through the bearing housing opening.

If the pump is to be disassembled further, **refer to Disassembly, page 4**.

ELASTOMERIC BELLOWS AND PTFE WEDGE TYPE

Elastomeric bellows and PTFE wedge seals generally require pump disassembly to be replaced (See Disassembly, steps 1-5, page 4).

1. Loosen nuts and remove seal plate, seal plate holder, seal seat and seal gasket(s).
2. Loosen setscrew in set collar (bellows) or mechanical seal rotary member (wedge). **NOTE:** Piping and/or plugs will need to be removed to access setscrews.
3. The remainder of the mechanical seal may be removed in conjunction with Step 7 of Disassembly, page 4.

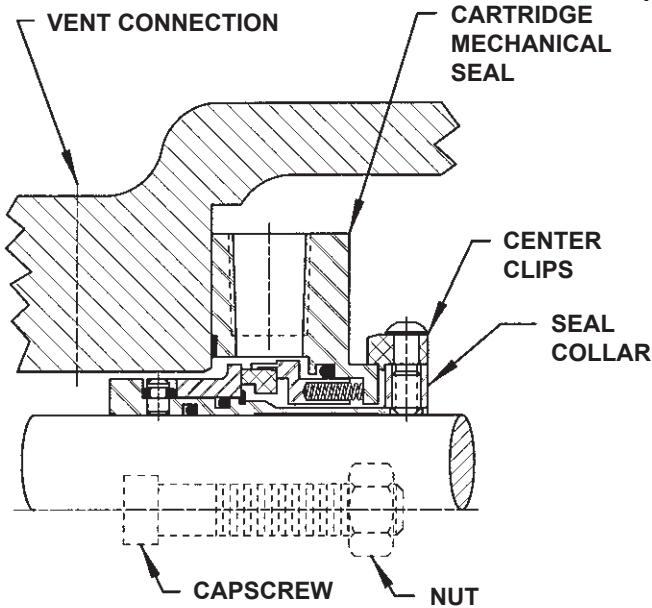
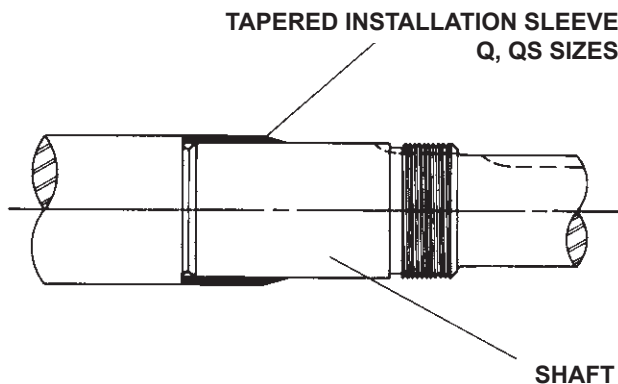

FIGURE 7
CARTRIDGE MECHANICAL SEAL

SEAL INSTALLATION



COAT ROTOR SHAFT, TAPERED INSTALLATION SLEEVE AND INNER DIAMETER OF MECHANICAL SEAL WITH LIGHT OIL BEFORE ASSEMBLY.

FIGURE 8

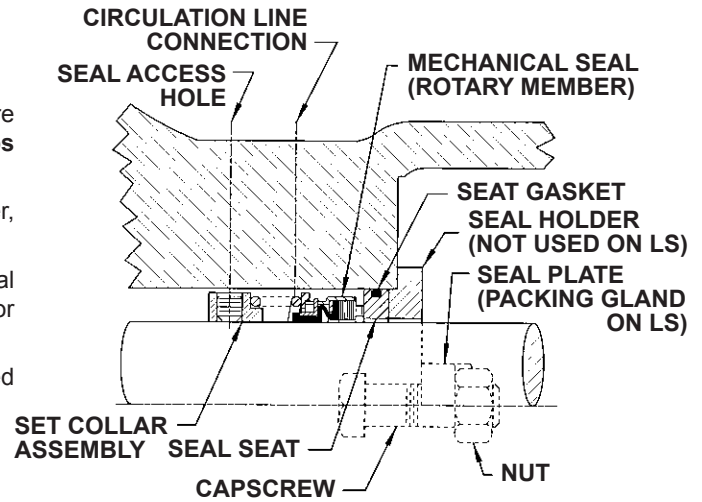

FIGURE 9
ELASTOMERIC BELLOWS SEAL

CARTRIDGE TYPE

1. **NOTE:** Burrs left on shaft can damage O-ring on seal sleeve during installation. Inspect shaft for burrs and remove any found with a fine grade of emery cloth.
2. Clean rotor shaft and face of seal chamber.
3. Slide cartridge seal on shaft until it contacts the seal chamber face.
4. Follow steps 9-12 on page 6 under Assembly.
5. Insert gland capscrews and secure gland to bracket face. **NOTE:** Turn shaft several turns while gland is loose to center seal; then tighten gland tight enough to compress gasket. Tighten only enough to contain leakage and not to distort gland.
6. Lock cartridge seal drive collar to shaft and remove or turn centering clips out of the way so as to clear the drive collar.
7. Turn shaft by hand or jog motor to check drive collar for runout.
8. Connect circulation line or vent stuffing box seals without line until liquid is present on start up.

NOTE: For maximum seal life, circulation line should be used.

DANGER !

Before starting pump, be sure all drive equipment guards are in place.

Failure to properly mount guards may result in serious injury or death.

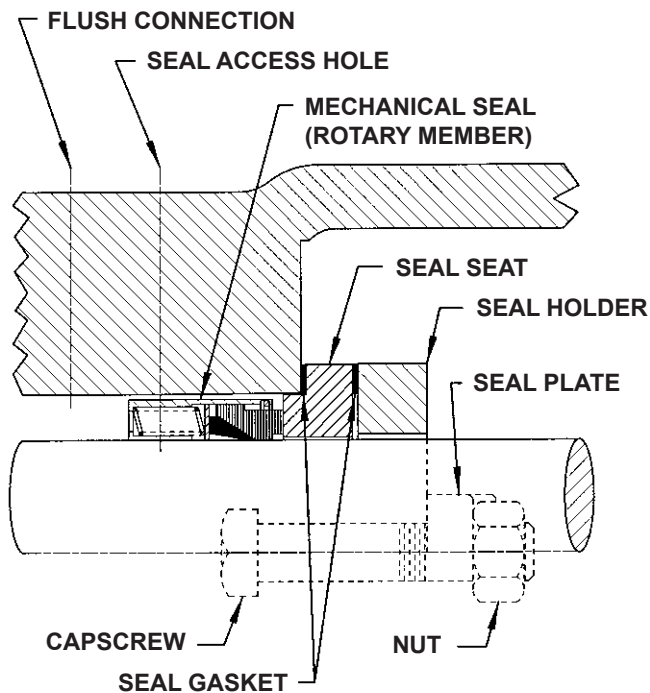

FIGURE 10
PTFE WEDGE SEAL

ELASTOMERIC BELLOWS AND PTFE WEDGE TYPE - Q, QS SIZES

For complete pump assembly instructions, see Assembly, page 5.

1. Clean rotor shaft and seal housing bore. Make sure they are free of dirt, grit and scratches. Gently radius leading edge of shaft diameter over which seal is to be placed.
NOTE: Never touch mechanical seal faces with anything except clean hands or clean cloth. Minute particles can scratch the seal faces and cause leakage.
2. Place tapered installation sleeve on the shaft (See Figure 11). Q, QS sizes only.
3. Coat outside of tapered installation sleeve and inside of rotary member of the seal with a generous quantity of light oil. Grease is not recommended.
4. Start rotary member on shaft (including seat collar and screws on bellows seal) and ease over tapered sleeve (See Figure 11).

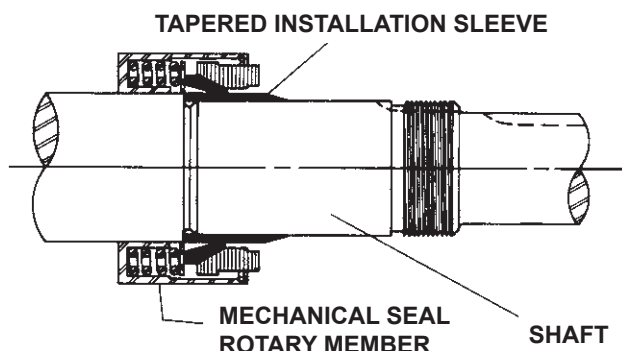

FIGURE 11

NOTE: Some PTFE wedge seals are equipped with holding clips, which compress the seal springs. Remove holding clips to release springs after seal is installed on shaft.

5. Move rotary member so set screws are directly below seal access holes on side of bracket (See Figure 9, page 7 and Figure 10). Tighten all setscrews securely to shaft.

NOTE: Be sure that the rotor and shaft are positioned against the head before tightening set screws.

6. **FOR "O-RING" GASKET TYPE MECHANICAL SEAL SEAT (BELLOWS SEAL):** Lubricate outer diameter of O-ring seal gasket with oil. Flush sealing faces of both rotary member and seal seat with oil and press seal seat in to bore until back, unlapped face, is flush with bore. Install seal holder, seal plate, capscrews, and nuts and tighten securely.

FOR "CLAMPED-IN" TYPE MECHANICAL SEAL SEAT (WEDGE SEAL): Flush sealing faces of both rotary member and seal seat with oil and install seal seat and seat gasket over end of shaft against machined bracket face. Install other seal gasket, seal holder, seal plate, capscrews and nuts and fasten securely.

7. Remove tapered installation sleeve.
8. Connect circulation line or vent stuffing box for seals without flush line until liquid is present on start up.

NOTE: For maximum seal life, circulation line should be used.

Refer to Assembly, page 5 to complete assembly.

THRUST BEARING ADJUSTMENT

1. Loosen the two set screws in the outer face of the bearing housing and turn this thrust bearing assembly clockwise until it can no longer be turned by hand. Back off counter-clockwise until the rotor shaft can be turned by hand with a slight noticeable drag.
2. For standard end clearance, back off the thrust bearing assembly the required length measured on the outside diameter of the bearing housing. See Table 1, page 9.
3. Tighten the two self-locking type "Allen" set screws, in the outboard face of the bearing housing, with equal force against the bracket. Your pump is now set with standard end clearances and locked.

NOTE: Be sure the shaft can rotate freely. If not, back off additional length on outside diameter and check again.

4. High viscosity liquids required additional end clearances. The amount of extra end clearance depends on the viscosity of the liquid pumped. For specific recommendations, consult the factory. Table 1 shows the additional bearing housing adjustment required for .001" increase in end clearance.

PUMP SIZE	MODEL	STANDARD END CLEARANCE (Inch)	TURN BRG. HOUSING C.C.W. LENGTH ON O.D. (Inch)	ADDITIONAL LENGTH ON O.D. BRG. HOUSING FOR .001" END CL. (Inch)
LS	124A 4124A 126A 4126A 123A 4123A	.005	1.25	.25
	224A 224AH 4224A 4224AH 226A 4226A 223A 4223A 124E 124EH	.010	2.50	
	127A 4127A	.010	2.50	
	227A 4227A	.20	5.00	
Q QS	124A 4124A 126A 4126A 123A 4123A	.010	3.10	.31
	224A 4224A 226A 4226A 223A 4223A 124E	.015	4.65	
	127A 4127A	.010	3.10	
	227A 4227A	.020	6.20	

TABLE 1

INSTALLATION OF CARBON GRAPHITE BUSHINGS

When installing carbon graphite bushings, extreme care must be taken to prevent breaking. Carbon graphite is a brittle material and easily cracked. If cracked, the bushing will quickly disintegrate. Using a lubricant and adding a chamfer on the bushing and the mating part will help in installation. The additional precautions listed below must be followed for proper installation.

1. A press must be used for installation.
2. Be certain bushing is started straight.
3. Do not stop pressing operation until bushing is in proper position. Starting and stopping will result in a cracked bushing.
4. Check bushing for cracks after installation.

Carbon graphite bushings with extra interference fits are frequently furnished for high temperature operation. These bushings must be installed by a shrink fit.

1. Heat bracket for idler to 750°F.
2. Install cool bushing with a press.
3. If facilities are not available to reach 750°F. temperature, it is possible to install with 450°F. temperature; however the lower the temperature the greater the possibility of cracking the bushing.
4. Consult factory with specific questions on high temperature applications. **Refer to Engineering Service Bulletin ESB-3.**

PRESSURE RELIEF VALVE INSTRUCTIONS

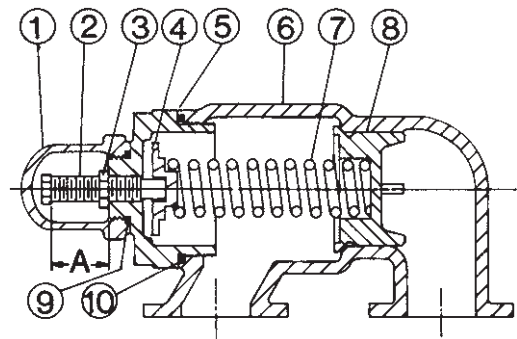

VALVE - LIST OF PARTS	
1. Valve Cap	6. Valve Body
2. Adjusting Screw	7. Valve Spring
3. Lock Nut	8. Poppet
4. Spring Guide	9. Cap Gasket
5. Bonnet	10. Bonnet Gasket

FIGURE 12
SIZE LS

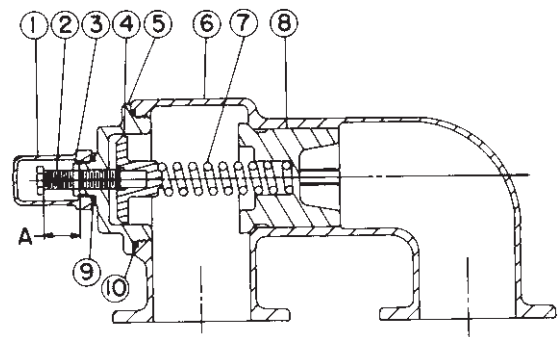

VALVE - LIST OF PARTS	
1. Valve Cap	6. Valve Body
2. Adjusting Screw	7. Valve Spring
3. Lock Nut	8. Poppet
4. Spring Guide	9. Cap Gasket
5. Bonnet	10. Bonnet Gasket

FIGURE 13
SIZES Q AND QS

DISASSEMBLY

Mark valve and head before disassembly to insure proper reassembly.

1. Remove valve cap.
2. Measure and record length of extension of adjusting screw. Refer to "A" on Figure 12, page 9 and Figure 13.
3. Loosen locknut and back out adjusting screw until spring pressure is released.
4. Remove bonnet, spring guide, spring and poppet from valve body. Clean and inspect all parts for wear or damage and replace if necessary.

ASSEMBLY

Reverse procedures outlined under Disassembly. If valve is removed for repairs be sure to replace in same position. Relief valve adjusting screw cap must always point towards suction side of pump. If pump rotation is reversed, remove relief valve and turn end for end.

PRESSURE ADJUSTMENT

If a new spring is installed or if pressure setting of pressure relief valve is to be changed from that which the factory has set, the following instructions must be carefully followed.

1. Carefully remove valve cap, which covers adjusting screw.
2. Loosen locknut (which locks adjusting screw so pressure setting will not change during operation of pump).
3. Install a pressure gauge in discharge line for actual adjusting operation.
4. Turn adjusting screw in to increase pressure and out to decrease pressure.
5. With discharge line closed at point beyond pressure gauge and pump running, gauge will show maximum pressure that the valve will allow (full bypass).

IMPORTANT

In ordering parts for pressure relief valve, always give model number and serial number of pump as it appears on nameplate and name of part wanted. When ordering springs, be sure to give pressure setting desired.

HEAT CARTRIDGES

This section applies to 124E Series only.

ASSEMBLY

INSTALLATION INSTRUCTIONS:

WARNING !

The pump needs to be properly grounded before the heat cartridges are installed.

1. Spacers should be installed between the foot of the pump and the base. This will create an air gap between the pump and base to limit heat transfer to the base.
2. Coat the threads of the heat cartridge with an anti-seize compound prior to installation. Install heat cartridges into the tapped ports on the head and bracket in the locations shown in the Figure 13 below. Figure 13 also shows the minimum clearance around the pump needed to install and remove the heat cartridges as well as the location for the thermocouple. The number of heaters used and the total wattage for each pump size is given in Table 2 below. 3/8" heat cartridges should be tightened to 10ft-lbs. 1/2" and 3/4" heat cartridges should be tightened to 20 ft-lbs.
3. Viking recommends installing a closed loop temperature controller with a control algorithm that will minimize or prevent overshooting the set point temperature. The set point temperature needs to be slightly higher than the melting point and significantly lower than the flash point or boiling point of the liquid being pumped. Viking does offer a controller for use with our heat cartridges. Ask your local Viking distributor for details.

WARNING !

Setting the set point temperature higher than necessary will not make the pump heat any faster and will shorten the life of the heat cartridges.

4. Properly insulate the pump to minimize heat loss. The pump will not heat properly if it is not insulated.

DANGER !

- Always disconnect, lockout, and tag out supply circuits prior to installing.
- The installation must comply with standard and local regulations.
- All wiring should be done by a licensed electrician to meet local codes.
- Study this manual thoroughly before installing and using the heat cartridges.
- Pay special attention to this section and the parts marked "WARNING!" or "DANGER".
- Should questions or uncertainties arise, please contact your authorized Viking distributor.

Failure to follow these instructions may cause an electrical shock and/or sparks, which may result in serious injury or death.

NOTE:

- Heat cartridges, temperature probes, and controllers must be wired by a licensed electrician to meet local codes.
- Heat cartridges require 240VAC, 1 Phase, 60 Hz or 220VAC, 1 Phase, 50 Hz power supply.
- Heat cartridges are UL, CSA, & CE marked, RoHs compliant.
- Heat cartridges and cables are water resistant but not water proof. They need to be installed in a protected area.
- To make sure that the liquid within the pump is melted and to avoid damage to the pump, do not start the pump until the set point temperature has been reached.
- Several factors such as the size of pump, the set point temperature, and the insulation will affect the amount of time it will take for the pump to reach the set point temperature. Typically it will take 3-4 hours for the pump to reach its set point temperature.
- Do not use heat cartridges with different watt densities from those supplied by Viking. Changing watt densities may result in localized over or under heating.
- The thermocouple or temperature probe must be installed in the bracket location shown in Figure 13 below. Any other location may result in localized over or under heating.
- Please see TSM 630.4 for technical information on the Viking supplied controller for the heat cartridges.
- The wires for the heat cartridges can be joined together in a junction box, and a single wire from the junction box can be connected to the controller.
- WARNING** Heat cartridges will be hot. Do not touch pump or heat cartridges until they have been allowed to cool.

Dimensions - LS through QS Sizes – Electrically Heated – Non Jacketed

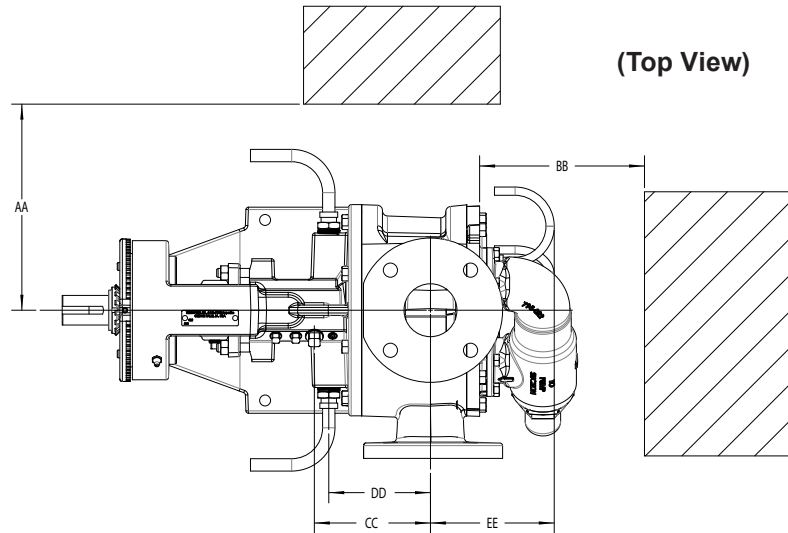

Model	Bracket Heater to Port Center Line (DD)		Temp Probe to Port Center Line (CC)		Head Heater to Port Center Line (EE)		Required to Remove Heater			
	Inch	mm	Inch	mm	Inch	mm	(AA)		(BB)	
							Inch	mm	Inch	mm
LS124E	6.09	154.69	6.25	158.75	6.44	163.58	7.00	177.80	6.50	165.10
Q124E	5.83	148.08	7.33	186.18	8.25	209.55	9.25	234.95	7.75	196.85
QS124E	6.33	160.78	7.83	198.88	9.25	234.95				

FIGURE 13 - HEAT CARTRIDGE AND THERMOCOUPLE LOCATIONS

* The thermocouple location for the LS size is located on the opposite side of the bracket as shown in the drawing.

Wattage by Pump Size			
Pump Size	Number of Heaters in Head	Number of Heaters in Bracket	Total Wattage
LS	2	2	1250
Q	3	2	2200
QS	3	2	2200

TABLE 2 - NUMBER OF HEAT CARTRIDGES IN EACH PUMP MODEL



TECHNICAL SERVICE MANUAL

UNIVERSAL SEAL HEAVY DUTY PUMPS
 SERIES 124A/E/EH, 4124A, 224A/AH, AND 4224A/AH CAST IRON
 SERIES 126A, 4126A, 226A AND 4226A DUCTILE IRON
 SERIES 123A, 4123A, 223A AND 4223A STEEL
 SERIES 127A, 4127A, 227A AND 4227A STAINLESS STEEL
 SIZES LS, Q AND QS

SECTION	TSM 630.2
PAGE	12 OF 12
ISSUE	I



WARRANTY

Viking warrants all products manufactured by it to be free from defects in workmanship or material for a period of one (1) year from date of startup, provided that in no event shall this warranty extend more than eighteen (18) months from the date of shipment from Viking. The warranty period for Universal Seal series pumps ONLY (Universal Seal models listed below) is three (3) years from date of startup, provided that in no event shall this warranty extend more than forty-two (42) months from the date of shipment from Viking.

UNDER NO CIRCUMSTANCES SHALL VIKING BE LIABLE UNDER THIS WARRANTY OR OTHERWISE FOR SPECIAL, INCIDENTAL, INDIRECT, CONSEQUENTIAL OR PUNITIVE DAMAGES OF ANY KIND, INCLUDING, BUT NOT LIMITED TO, LOST OR UNREALIZED SALES, REVENUES, PROFITS, INCOME, COST SAVINGS OR BUSINESS, LOST OR UNREALIZED CONTRACTS, LOSS OF GOODWILL, DAMAGE TO REPUTATION, LOSS OF PROPERTY, LOSS OF INFORMATION OR DATA, LOSS OF PRODUCTION, DOWNTIME, OR INCREASED COSTS, IN CONNECTION WITH ANY PRODUCT, EVEN IF VIKING HAS BEEN ADVISED OR PLACED ON NOTICE OF THE POSSIBILITY OF SUCH DAMAGES AND NOTWITHSTANDING THE FAILURE OF ANY ESSENTIAL PURPOSE OF ANY PRODUCT.

THIS WARRANTY IS AND SHALL BE VIKING'S SOLE AND EXCLUSIVE WARRANTY AND SHALL BE IN LIEU OF ALL OTHER WARRANTIES, EXPRESS OR IMPLIED, INCLUDING, BUT NOT LIMITED TO, ALL WARRANTIES OF MERCHANTABILITY, FITNESS FOR A PARTICULAR PURPOSE AND NON-INFRINGEMENT ALL OF WHICH OTHER WARRANTIES ARE EXPRESSLY EXCLUDED.

See complete warranty at www.vikingpump.com.

