

APV DELTA AP1/APT1

ASEPTIC PROCESS VALVE

FORM NO.: H317551 REVISION: UK-1

READ AND UNDERSTAND THIS MANUAL PRIOR TO OPERATING OR SERVICING THIS PRODUCT.



EU Declaration of Conformity for Valves and Valve Manifolds

SPX Flow Technology Germany GmbH
Gottlieb-Daimler-Str. 13, D-59439 Holzwickede
herewith declares that the

**APV double seal and double seat valves of the series
SD4, SDT4, SDU4, SDMS4, SDMSU4, SDTMS4, SWcip4, DSV,
DA4, D4 SL, D4, DA3, DA3SLD, DE3, DEU3, DET3, DKR2, DKRT2, DKRH2**
in the nominal diameters DN 25 - 150, ISO 1" – 6" and 1 Sh5 - 6 Sh5

APV butterfly valves of the series SV1 and SVS1F, SVL and SVSL
in the nominal diameters DN 25 - 100, DN 125 - 250 and ISO 1" – 4"

APV ball valves of the series KHI, KHV
in the nominal diameters DN 15 - 100

**APV single seat, diaphragm and spring loaded valves of the series
S2, SW4, SWhp4, SW4DPF, SWmini4, SWT4, SWS4, MF4, MS4, MSP4, AP/T1, CPV,
RG4, RG4DPF, RGMS4, RGE4, RGE4DPF, RGEMS4, PR2, PRD2, SI2, UF/R3, VRA/H**
in the nominal diameters DN 10 - 150, ISO 1/2" – 4" and 1 Sh5 - 6 Sh5

and the valve manifolds installed thereof

meet the requirements of the Directives 2006/42/EC (superseding 89/392/EEC
and 98/37/EC) and ProdSG (superseding GPSG - 9.GPSGV).

For official inspections, SPX FLOW presents
a technical documentation according to Appendix VII of the Machinery Directive,
this documentation consisting of documents of the development and construction,
description of measures taken to meet the conformity and to correspond with
the basic requirements on safety and health, incl. an analysis of the risks,
as well as an operating manual with safety instructions.

The conformity of the valves and valve manifolds is guaranteed.

Authorised person for the documentation:
Frank Baumbach

SPX Flow Technology Germany GmbH
Gottlieb-Daimler-Str. 13, D-59439 Holzwickede, Germany

May 2018

ppa. Baumbach

Frank Baumbach
Regional Engineering Manager, F&B Components

Content	Page
1. General Terms	2
2. Safety Instructions	2
3. Intended Use	2
4. Mode of Operation	3
4.1 General terms	
5. Auxiliary Equipment	4
5.1 Valve position indication/proximity switch	
5.2 Valve position indication/micro switch	
6. Installation	5
6.1 Welding instructions	
6.2 Dimensions in mm for tank bore	
7. Dimensions	6
7.1 Dimensions AP1	
7.2 Dimensions APT1	
7.3 Weights in kg	
8. Technical Data	8
8.1 General terms	
8.2 Specification of compressed air quality	
8.3 Closing times	
8.4 Valve strokes/closing pressure/opening section	
8.5 Flow values kvs in m ³ /h	
9. Materials	10
10. Maintenance	12
11. Service Instructions	14
11.1. Dismantling from the line system AP1/APT1	
11.2. Disassembly of product-wetted sealing elements	
11.3. Dismantling and maintenance of actuator unit	
11.4. Assembly of actuator unit	
11.5. Assembly of product-wetted sealing elements	
11.6. Assembly of valve	
12. Trouble Shooting	16
13. Spare Parts Lists	

AP1, APT1 - actuated design

RN 01.064.8

AP1, APT1 - manual design

RN 01.064.8-1

1. General Terms

This instruction manual must be read carefully by the competent operating and maintenance personnel.
We point out that we will not accept any liability for damage or malfunctions resulting from the non-compliance with this operating manual.
Descriptions and data given herein are subject to technical changes.

2. Safety Instructions

**Danger!**

The technical safety symbol draws your attention to important directions for operating safety. You will find it wherever the activities described are bearing risks of personal injury.

- Separate electric and pneumatic connections.
- **Depressurize** and, if possible, discharge the line and cleaning system before any maintenance work!
- Observe Service Instructions to ensure safe maintenance of the valve.
- Seal connections which are not used with a plug!
- Ensure the safe discharge of the cleaning liquids!
- **Do not touch the open valve.**
- Do not open the actuator by force! It is under spring tension!

**Attention!**

Valve design NC: Relieve the valve insert by controlling the actuator before releasing the clamp!

3. Intended Use

The intended use as field of application of the AP valve is the shut-off of line sections.
Arbitrary, constructive changes at the valve will influence safety as well as the intended functionality of the valve and are not permissible.

Authorizations and External Approvals

To view the certifications for this and other innovative SPX FLOW products, visit
<https://www.spxflow.com/en/apv/about-us/certifications/>

4. Mode of Operation

4.1 General terms

Due to its construction and mode of operation as well as the use of high-quality stainless steel and the corresponding seal materials, the aseptic process valve APV DELTA AP1 can be used in the food and beverage as well as in the pharmaceutical and chemical industries.

The function of the valve is to shut off line sections.

The diaphragm valves offer optimum protection of the product in hygienic and aseptic applications.

Product safety is provided by the hermetic separation of the product chamber from the environment (atmosphere) by a flexible diaphragm shaft.

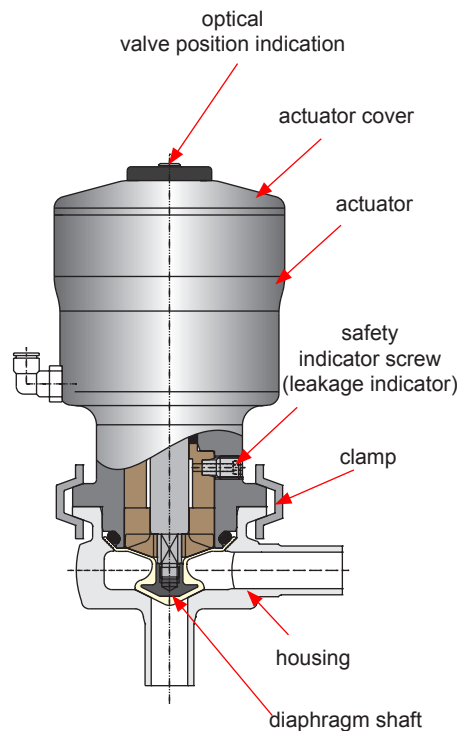

- Different variants are available:
 - Type: AP1 - NC (FS) (NC = normally closed; air-to-raise, spring-to-lower)
 - Type: AP1 - NO (FH) (NO = normally open; air-to-lower, spring-to-raise)
 - Type: AP1 - AA (LL) (AA = air/air actuator)
 - Type: AP1 - M (H) (M = manual operation)
- Operation by pneumatic stroke actuator with air connection, reset by spring force.
- The cleaning of the inner area of the valve is undertaken during CIP cleaning of the line system.
- Leakages at the diaphragm are indicated at the safety indicator screw at the leakage drain.
- Maintainable actuator.
- Optical valve position indicator on the actuator cover.
- The pneumatic actuator can be equipped with an electric position switch (proximity switch) to indicate the current valve position.
- The valve diaphragm shaft is made of TFM material.
- Different housing variants (see spare parts drawings) are available.
- **Connections**

Beside the housings with weld ends according to DIN 11850 and ISO 1127 the following connections are available:

 - clamp connection according to DIN 32676
 - clamp connection according to ISO 2852

5. Auxiliary Equipment

5.1 Valve position indication / proximity switch

- The pneumatic actuator is equipped with one or two electric position switches (proximity switches) to indicate the current valve position.

feedback of valve position by proximity switch (PSH1)

feedback of valve position by two proximity switches (PSH2)

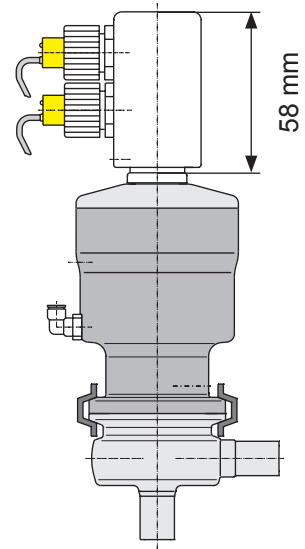
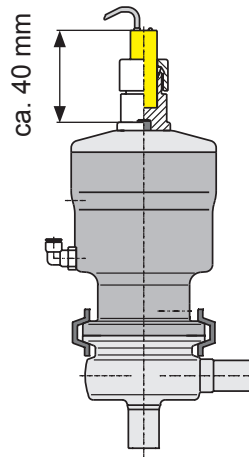

5.2 Valve position indication / micro switch

- The pneumatic actuator can be equipped with an electric position switch (proximity switch) to indicate the current valve position.

feedback of valve position by two micro switches

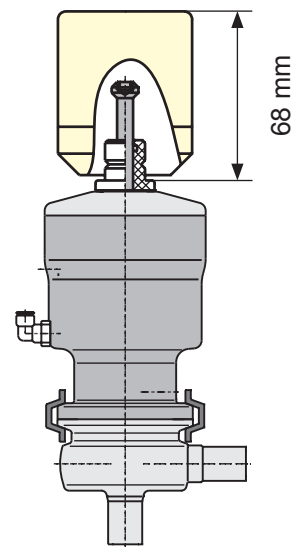

6. Installation

- The installation of the valve must be undertaken in such a manner that fluids can drain off the valve housing and should preferably be provided in vertical position.
- The valve housing can be welded direct into the pipeline (completely dismantable valve insert).

Attention! Observe welding instructions.

6.1 Welding Instructions Shut-off valve AP/APT

- Before welding of the valve, the valve insert must be dismantled from the housing (see paragraph 11.1.2. - 4.). Careful handling to avoid damage to the parts is necessary.
- To weld APT valves in tanks, the corresponding dimensions for the preparation of the tank bore can be drawn from table 1.
- Welding should only be carried out by certified welders DIN EN ISO 9606-1). (seam quality DIN EN ISO 5817).
- The welding of the valve housings must be undertaken in such a way that the valve body is not deformed.
- The preparation of the weld seam must be carried out as a square butt joint without air. (Consider shrinkage!)
- TIG orbital welding is best.
- ! After welding of the valve housings or of the mating flanges and after work at the pipelines, the corresponding parts of the installation or pipelines must be cleaned from welding residues and soiling. If these cleaning instructions are not observed, welding residues and dirt particles can damage or destroy the diaphragm shaft.
- Any damage resulting from the non-observance of these welding instructions is not subject to our guarantee.
- Welding directives for aseptic applications shall be drawn from the AWS/ANSI Directives and EHEDG Guidelines.

6.2 Dimensions in mm for tank bore

DN	Inch	$\varnothing C_{-0,1}$	h
10	1/2"	46	3
15		46	3
20		46	5

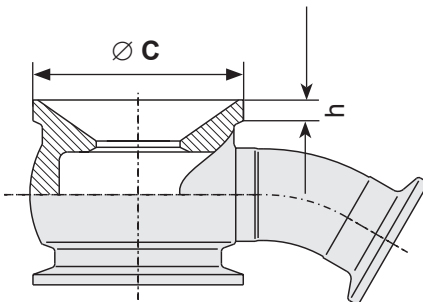

7. Dimensions

7.1 Dimensions AP1

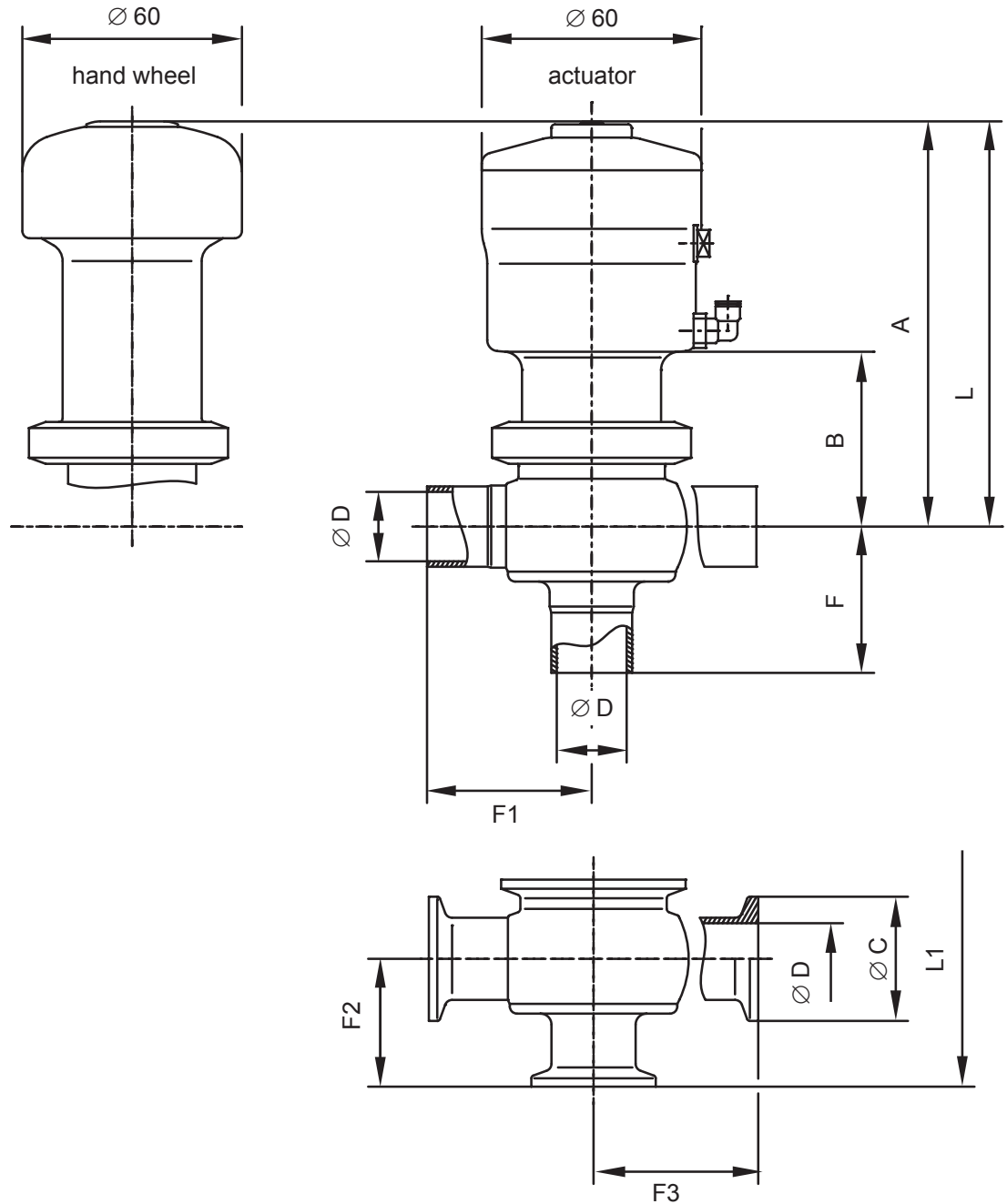

Dimensions in mm

DN	$\varnothing D$	F	F1	F2	F3	A	B	$\varnothing C$	L	L1
1/2"	9,5	30	45	19,5	41	105	43	25	135	124,5
10	10	30	45	19,5	41	105	43	25	135	124,5
15	16	35	45	30	45	108	46	34	153	138
20	20	40	45	35	45	110	48	34	155	145

7. Dimensions

7.2 Dimensions APT1

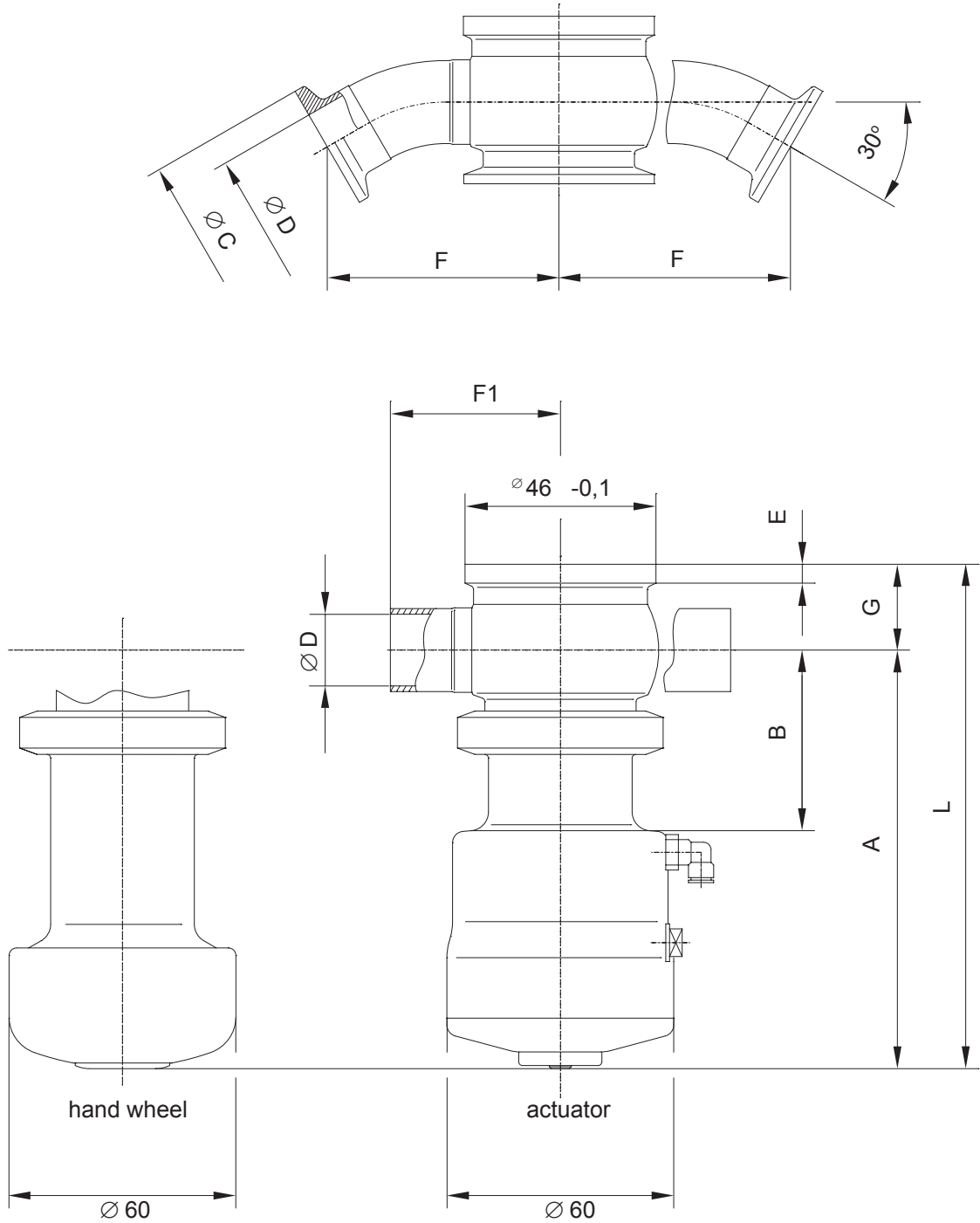

Dimensions in mm

DN	$\varnothing D$	F	F1	A	B	$\varnothing C$	E	G	L
1/2"	9,5	53,5	45	105	43	25	3	17,5	122,5
10	10	53,5	45	105	43	25	3	17,5	122,5
15	16	63	45	108	46	34	3	18,7	123,7
20	20	66	45	110	48	34	5	22,8	132,8

7. Weights

7.3 Weights in kg

AP1-NC = actuator operated
 AP1-M = manual operation

DN/Inch	AP1 - NC metal actuator	AP1 - NC plastic actuator
10/1/2"	1,5 kg	0,9 kg
15	1,6 kg	1,0 kg
20	1,65 kg	1,05 kg

DN/Inch	AP1 - M metal actuator	AP1 - M plastic actuator
10/1/2"	1,2 kg	0,85 kg
15	1,3 kg	0,95 kg
20	1,35 kg	1,0 kg

8. Technical Data

8.1 General terms

line pressure: 10 bar

max. operating temperature: 135 °C
 short-term load: 150 °C

air connection (for hose): 4 x 1 mm standard

max. pneumatic air pressure: 10 bar
 min. pneumatic air pressure: 6 bar

8.2 Specification of compressed air quality

Compressed air quality: quality class acc. to DIN ISO 8573-1

content of solid particles: **quality class 3**
 max. size of solid particles per m³
 10000 of 0,5 µm < d < 1,0 µm
 500 of 1,0 µm < d < 5,0 µm

content of water **quality class 3**
 max. dew point temperature -20 °C
 For installations at lower temperatures or at higher altitudes, additional measures must be considered to reduce the pressure dew point accordingly.

content of oil: **quality class 1**
 max. 0,01mg/m³

The oil applied must be compatible with Polyurethane elastomer materials.

8. Technical Data

8.3 Closing times

closing time in sec. at pneumatic pressure of 6 bar

DN	hose length 1 m	hose length 10 m
10, 15, 20	0,1 sec.	0,4 sec.

8.4 Valve strokes/closing pressure/opening section

DN	AP1 shut-off valve		
	stroke	closing pressure	opening section (d)
10	4 mm	10 bar	∅ 3,6 mm
15	4 mm	10 bar	∅ 3,6 mm
20	4 mm	10 bar	∅ 3,6 mm

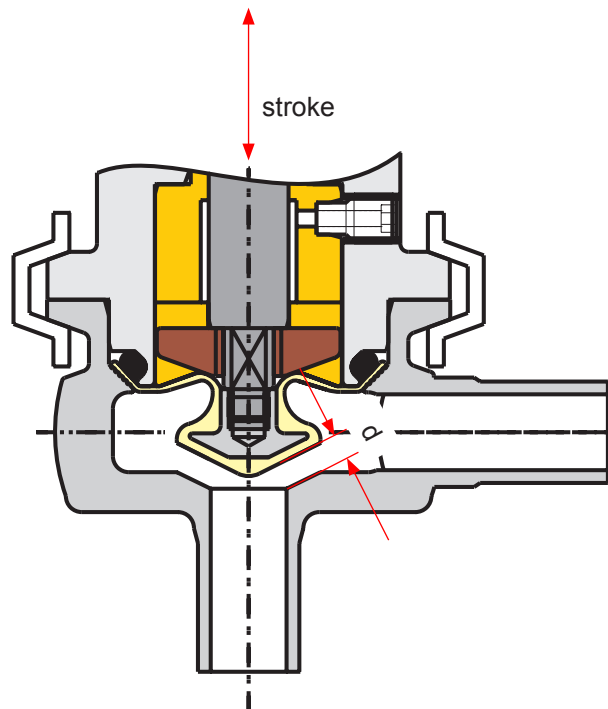

8. Technical Data

8.5 Flow values kvs in m³/h

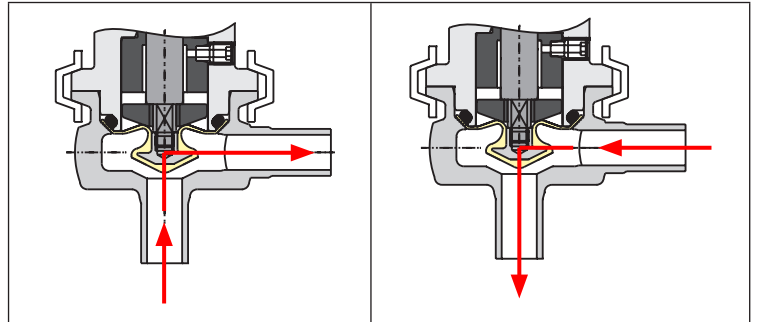

DN	Inch		
10	1/2"	1,5 m ³ /h	1,5 m ³ /h
15			
20		5,5 m ³ /h	7,0 m ³ /h

9. Materials

Product-wetted parts

- housing: **1.4404 (316L)**
(DIN EN 10088)
option 1.4435
(DIN EN 10088)

Other parts

- actuator, actuator cover **PPS40**
option 1.4301 (304L)
(DIN EN 10088)
- piston rod, clamp **1.4301 (304L)**
(DIN EN 10088)
- proximity switch holder, plug **PA 12 black**

Seals

- diaphragm shaft **TFM**

10. Maintenance

- The maintenance intervals depend on the application and should be determined by the operator carrying out temporary checks.
- Tools required:
 - 1 x spanner SW8
 - 1 x spanner SW13
 - 1 x wrench SW12
 - 1 x wrench SW5
 - 1 x wrench SW3
- For the valve service we supply complete seal kits (pl. see spare parts lists). The appropriate seal grease forms part of this scope of supply.
- The replacement of seals is undertaken according to the Service Instructions.
- The disassembly and assembly of the valve is undertaken according to the Service Instructions.
- **All seals must be provided with a thin layer of grease before their installation!!!**

Attention! Use only food-grade grease and special grease being suited for the respective seal material.

Recommendation:

APV assembly grease for EPDM, FPM, HNBR and NBR
(0,75 kg /tin - ref.-No. 000 70-01-019/93; H147382)
(60 g /tube - ref.-No. 000 70-01-018/93; H147381)

Recommendation for screw retention

Type: Loctite 243 semi-solid
(50 ml - ref.-No. 00070-01-111/93; H206336)

Recommendation for piston seal

APV pneumatic grease:
(25 ml / tube - ref.-No. 000-70-01-008/93; H164725)

11. Service Instructions

11.1. Dismantling from the line system AP1/APT1

1. Shut off line pressure and discharge lines and tanks if possible.

2. **Valve design NC:** Control actuator with air.

Do not touch movable parts!
Risk of injury.

Valve design NO: For the disassembly from the line system compressed air is not required.

3. Remove the clamp and and lift the complete valve insert including actuator out of the housing.

Valve design NC: Cut off compressed air.

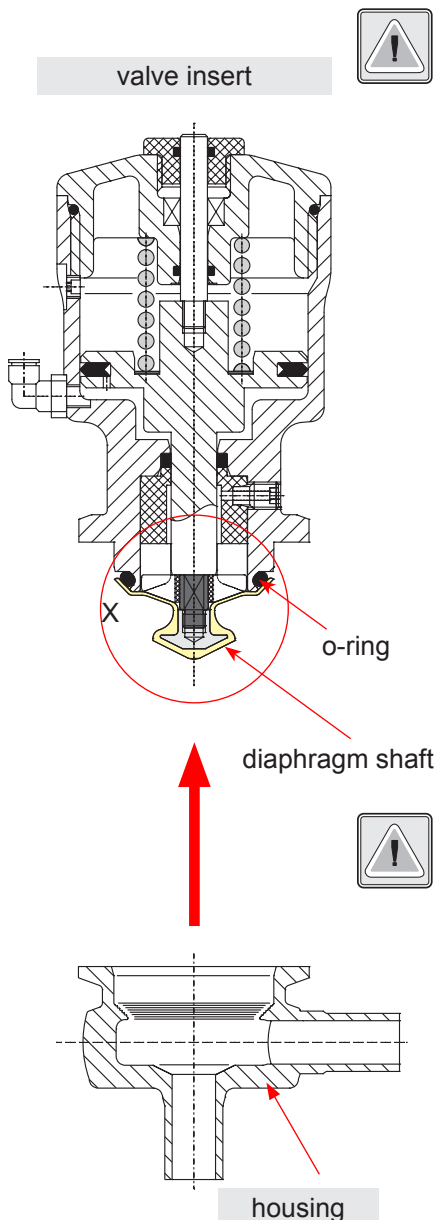

11.2. Dismantling of product-wetted seal elements

1. Pull the diaphragm shaft (2) from the piston rod (17) and remove the o-ring (21).

Valve design NO: Control the actuator with compressed air.

Do not touch movable valve parts!
Risk of injury.

2. Remove the diaphragm shaft and o-ring.
Cut off compressed air.

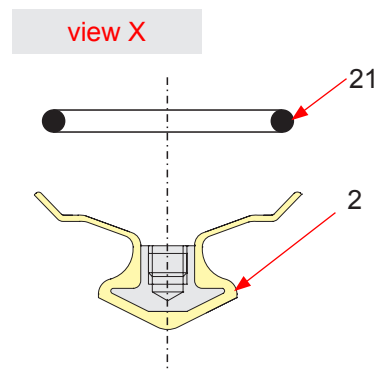

11. Service Instructions

11.3. Disassembly and maintenance of actuator unit

The item numbers refer to the spare parts drawings
AP1, APT1: actuated design RN 01.064.8

- **Design with valve position indicator:**
Remove the cover of the valve position indicator (22).
Turn off the actuating pin (24) with the wrench SW4.
Remove the adaptor plug (23) from the actuator cover.
- **Design with proximity switch holder:**
Remove the proximity switch (26).
Remove the proximity switch holder (25) from the actuator cover (10). Turn off the indicator pin (13) with a nipper.
Attention! Do not damage the indicator pin.

1. Turn off the thread pin (11) and remove the o-ring (12).
2. Turn the actuator cover (10) with the wrench SW12 off the actuator (6). Remove the o-ring (9) and the o-ring (12).
3. Pull the pressure spring (14), disc (16) and piston rod (17) to the top off the actuator. Remove the piston seal (15) from the piston
4. Turn off the safety indicator screw (19) with the wrench SW3. Remove the fan (3) and diaphragm support (4) to the bottom out of the actuator. Remove the quading (5).
5. All seals can be serviced.

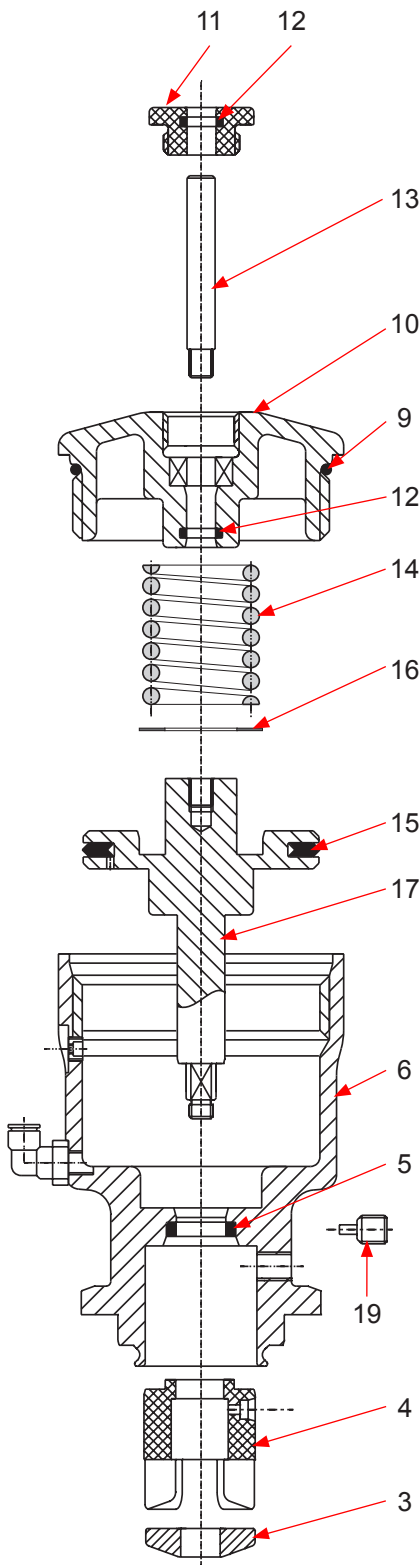

11. Service Instructions

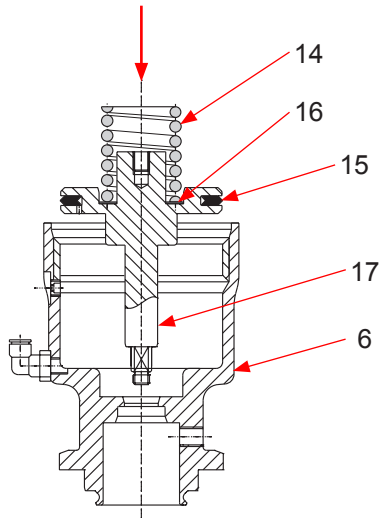

11.4. Assembly of actuator unit

The item numbers refer to the spare parts drawings
AP1, APT1: actuated design RN 01.064.8

! Provide all seals with a thin layer of grease.

! Attention! Only for the piston seal must the appropriate pneumatic grease be used (see paragraph 9).

1. Insert the piston seal (15) in the piston rod (17). Place the disc (16) in the groove of the piston rod. Insert the piston rod with disc from the top into the actuator (6) until it stops. Insert the pressure spring (14).

2. Insert the o-ring (12) and o-ring (9) in the housing cover. Turn the housing cover manually in the lower actuator.

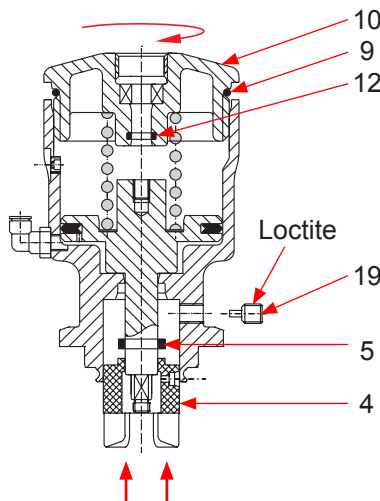

3. Slide the quadding (5) on the stud of the piston rod. Slide the diaphragm support (4) from the bottom into the actuator. During this process, the quadding is guided into the groove of the actuator.

Attention! When introducing the diaphragm support in the actuator, observe the bore position for the safety indicator screw (19).

4. Provide the thread of the safety indicator screw (19) with Loctite. Fasten the indicator screw in the thread of the actuator (diaphragm support is fixed by stud of indicator screw).

5. Insert the fan (3) in the diaphragm support (4).
Attention! The fan must lock in the diaphragm support.

6. Fasten the actuator cover (10) with a wrench SW12.

7. Provide the thread of the indicator pin (13) with Loctite. Turn the indicator pin manually through the actuator cover in the piston rod and tighten it with a nipper.

Attention! The indicator pin must not be damaged.

8. Insert the o-ring (12) in the thread plug. Tighten the thread plug.

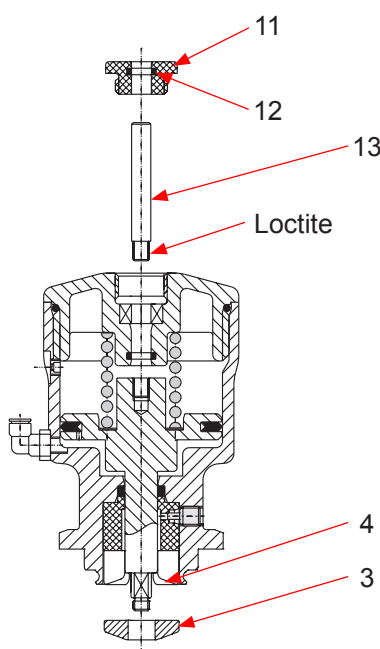

11. Service Instructions

11.5. Assembly of product-wetted sealing elements

1. Insert the o-ring (21) in the groove of the actuator. Fasten the diaphragm shaft (2) manually on the thread of the piston rod.

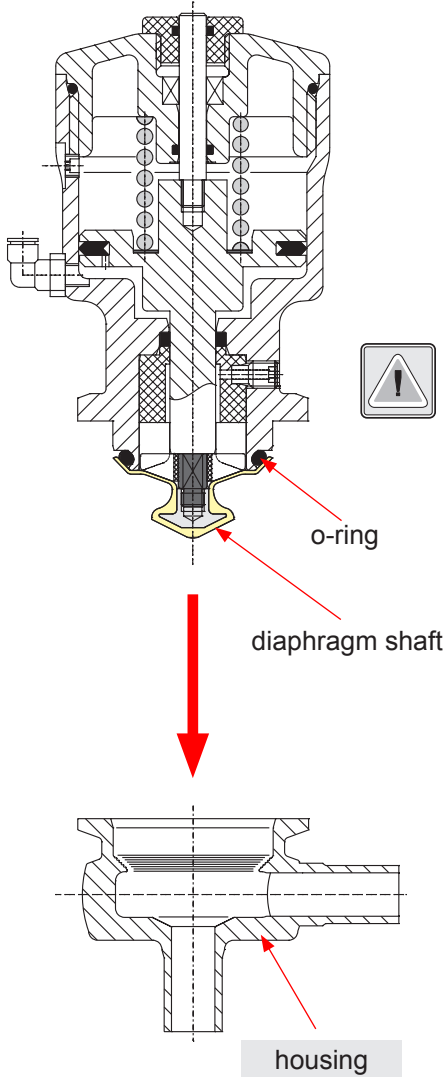

11.6. Assembly of valve

1. **Valve design NC:** Control the actuator with compressed air.

Do not touch movable valve parts!
Risk of injury.

2. **Attention!** Before placing the valve insert in the housing, clean the inner space of the housing. Use appropriate cleaning agent.
 - Place the valve insert in the housing and fasten it with the clamp.
3. Cut off compressed air.

Valve design NO: Compressed air is not required for assembly.

12. Trouble Shooting

Trouble	Remedy
Valve does not seal up. Leakage from the safety indicator screw.	Replace o-ring (21) and diaphragm shaft (2). Check line pressure: Adm. line pressure see paragraph 7.1
Leakage between housing and actuator in the clamp area.	Replace o-ring (21) and diaphragm shaft (2).
Actuator does not work, air escapes permanently in the area of the actuator cover or indicator pin.	Replace piston seal (15), o-ring (9) and o-rings (12).
Compressed air escapes from the safety indicator screw.	Replace quadring (5).
Valve position indication from proximity switch is missing or is imprecise.	Adjust proximity switch. Plug proximity switch in proximity switch holder until stop.
Leakage from the drain pipe	Remove the drain pipe (1) to check and find out reason.

! If damaged seals are replaced, generally all seals should be renewed. For valve service actions SPX FLOW supplies complete seal kits (see spare parts lists.)

13. Spare Parts Lists

The reference numbers of the spare parts for the different valve designs and sizes are included in the attached spare parts drawings with corresponding lists.

Please indicate the following data to place an order for spare parts:

- number of parts required
- reference number
- designation

Data are subject to change.

Weitergabe sowie Vervielfältigung dieser Unterlage, Verwertung und Mitteilung ihres Inhalts ist gestattet, soweit nicht schriftlich zugestanden. Verstoß verpflichtet zum Schadensersatz und kann strafrechtliche Folgen haben (Paragraf 18 UWG, Paragraf 106 UrhG). Eigentum und alle Rechte, auch für Patentierung und Gebrauchsmusteranmeldung, vorbehalten. SPX FLOW, Germany

Ersatzteilliste: spare parts list

**AP1, APT1-Ventil FS, FH, L/L, VSM-Microschalter, Initiatorhalter
AP1, APT1-valve NC, NO, air/air, PSH-microswitch, prox.switch holder
DN 1/2", 10, 15, 20-S und/and Clamp**

pos. item	Menge quantity	Beschreibung description	Material	DN1/2"	DN10 WS-Nr. ref.-no.	DN20 WS-Nr. ref.-no.	pump drain DN10 WS-Nr. ref.-no.	powdervolve DN10 WS-Nr. ref.-no.	Datei		Blatt 4 von 6 RN 01.064.8
									Datum: Name: Geprüft:	07.01.13 Tryko	
1	1	Steuerkopfdeckel Actuator cover	PPS 40			08-43-054/93 H317394					
11	1	Gewindestopfen Threaded plug	PA12 schwarz			08-74-045/93 H316263					
12	2	O-Ring O-ring	EPDM WS 287			58-06-026/63 H316244					
13	1	Anzeigestift Indicator pin	1.4301			08-07-224/12 H316265					
14	1	Druckfeder Pressure feather	1.4310			60-06-401/13 H316169					
15	1	Kolbendichtung Piston seal	NBR			58-01-010/83 H76274					
16	1	Scheibe Disk	1.4310			08-58-070/12 H316264					
17	1	Kolbenstange FS Piston rod NC	1.4301			15-23-966/12 H316266					
18	1	Kolbenstange FH Piston rod NO	1.4301			15-23-967/12 H316267					
19	1	Kolbenstange L/L Piston rod air/air	1.4301			15-23-968/12 H317624					
20	1	Sicherungs-Anzeigeschraube Safety-indicator screw	1.4301			08-07-225/12 H316262					
21	1	Gelenkklemme Joint clamp	1.4301			42-40-282/13 H121708					
22	1	O-Ring O-ring	FKM grün FPM			58-06-099/73 H316243					
23	1	VSM-Microschalter 12 VSM-Microswitch 12	1.4301 PA12			08-60-450/93 H316744					
24	1	Adapterstopfen Adapter pin	PA12 schwarz			08-74-044/93 H316637					
25	1	Betätigungsstift Actuating pin	1.4301			08-07-214/12 H316720					



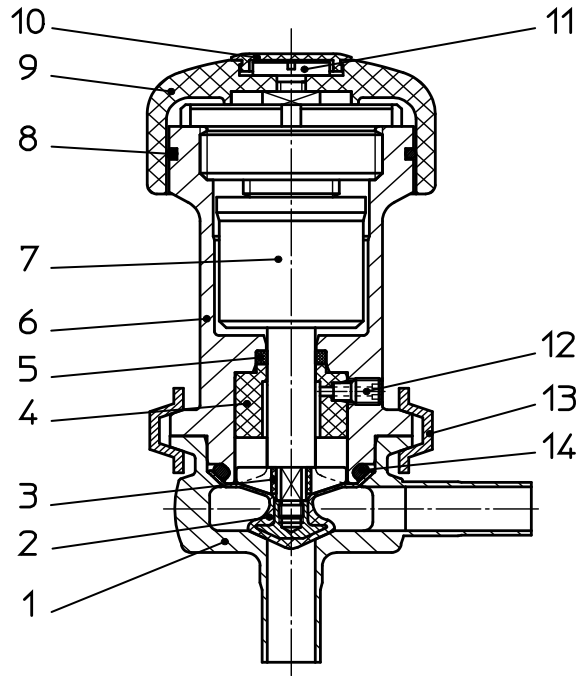

Gehäuseausführung
housing design

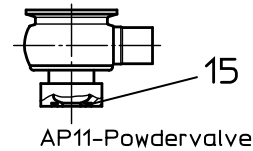
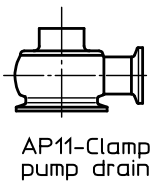
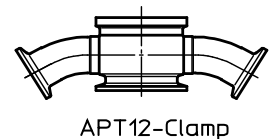
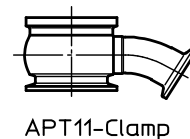
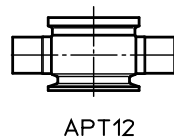
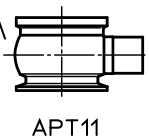
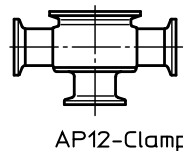
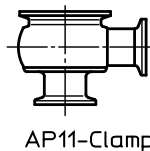
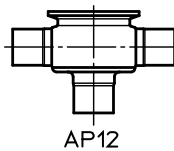
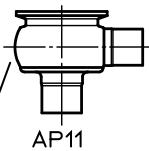

Weitergabe sowie Vervielfältigung dieser Unterlage, Verwertung und Mitteilung ihres Inhalts nicht gestattet, soweit nicht schriftlich zugestanden. Verstos verpflichtet zum Schadensersatz und kann strafrechtliche Folgen haben (Paragraph 18 UWG, Paragraph 106 UrhG). Eigentum und alle Rechte, auch für Patenterteilung und Gebrauchsmustereintragung, vorbehalten. SPX FLOW, Germany

Datum:	15.01.13										
Name:	Trytko										
Geprüft:											

Ersatzteilliste: spare parts list
AP1, APT1-Ventil Handantrieb
AP1, APT1-valve manual handle
DN 1/2", 10, 15, 20 -S und / and -Clamp



SPX FLOW
Germany

Blatt 1 von 4

RN 01.064.8-1

Weitergabe sowie Vervielfältigung dieser Unterlage, Verwertung und Mitteilung ihres Inhalts nicht gestattet, soweit nicht schriftlich zugestanden. Verstoß verpflichtet zum Schadensersatz und kann strafrechtliche Folgen haben (Paragraf 18 UWG, Paragraf 106 UrhG). Eigentum und alle Rechte, auch für Patenterteilung und Gebrauchsmustererteilung, vorbehalten. SPX FLOW, Germany

Ersatzteilliste: spare parts list

AP1, APT1-Ventil Handantrieb
AP1, APT1-valve manual handle
DN 1/2", 10, 15, 20 -S und / and -Clamp

Datum:	15.01.13	Blatt	3	von	4
Name:	Trytko				
Geprüft:					
Datum:					
Name:					
Geprüft:					

											
RN01.064.8-1											

pos. item	Menge	Beschreibung	Material	DN1/2"	DN10	DN15	DN20	pump drain DN10	powdervolve DN10
		description		WS-Nr. ref.-no.	WS-Nr. ref.-no.	WS-Nr. ref.-no.	WS-Nr. ref.-no.	WS-Nr. ref.-no.	WS-Nr. ref.-no.
1	1	Gehäuse AP11 1S Housing matt/finish	1.4404						
1	1	Gehäuse AP11 1S Housing handpoliert/manually polish.	1.4435						
1	1	Gehäuse AP11 1Clamp Housing metallblank/bright metal fin.	1.4404						
1	1	Gehäuse AP11 1Clamp Housing handpoliert/manually polish.	1.4435					318 39-41-149/86 H317786	000 39-41-900/47 H320004
2	1	Membranschaft Diaphragm shaft	TFM 1705	39-22-980/22 H316239	39-22-982/22 H318047	39-22-983/22 H316240			39-22-986/22 H317787
3	1	Stern AP10-20 Star AP10-20	PPS 40			08-48-501/93 H316237			
4	1	Membranunterstützung Membrane support	PPS 40			08-48-500/93 H316238			
5	1	Quadring QRAR 4111A-V7002	FKM			58-01-796/73 H316246			
1	1	Steuerkopf unten Actuator lower	1.4301			15-31-085/13 H316873			
6	1	Steuerkopf unten Actuator lower	1.4301			15-31-085/12 H316257			
1	1	Steuerkopf unten Actuator lower	PPS 40			15-31-085/93 H317395			
7	1	Kolbenstange Piston rod	1.4301			15-23-965/12 H316254			
8	1	O-Ring O-ring	FKM (FPM)			58-06-215/73 H316245			
9	1	Handrad Hand wheel	PPS 40			08-43-050/93 H316250			
10	1	Abdeckstopfen Plug	PE-LLD			08-74-046/93 H316286			
11	1	Flachkopfschraube Pan head screw	1.4301			65-04-327/13 H316805			

APV DELTA AP1/APT1

ASEPTIC PROCESS VALVE



SPX FLOW

Design Center

Gottlieb-Daimler-Straße 13
D-59439 Holzwickede, Germany
P: (+49) (0) 2301-9186-0
F: (+49) (0) 2301-9186-300

SPX FLOW

Production

Stefana Rolbieskiego 2
PL- Bydgoszcz 85-862, Poland
P: (+48) 52 566 76 00
F: (+48) 52 525 99 09

SPX FLOW reserves the right to incorporate the latest design and material changes without notice or obligation.

Design features, materials of construction and dimensional data, as described in this manual, are provided for your information only and should not be relied upon unless confirmed in writing. Please contact your local sales representative for product availability in your region.

For more information visit www.spxflow.com.

ISSUED 10/2018 - Translation of Original Manual

COPYRIGHT ©2018 SPX FLOW, Inc.