



EXPERIENCE THE EXCEPTIONAL

Seal Support Systems



the AESSEAL® group of companies

designers and manufacturers of mechanical seals,
bearing protectors and seal support systems
which maximize rotating equipment up-time.

www.aesseal.com

Contents

	Company Overview	3		Oil Support Systems	19
	Industry Expertise	6		SP Range	20
	API Piping Plans and Certification Made Easy	7		AES-15™	21
	The Importance of Fluid Film	8		PP/01™ PP/SOU™	22
	Water Management Systems	10		API Plan Systems	24
	Cyclone Separator	11		Gas Panel	27
	FLOWTRUE®	12		SMART TRACK® SMART TRACK II™	28
	SWM™ & SWP™	14		Top Up Trolley	30
	SW Range	15		Cooler Options	31
	SWFF-TF™	16		Optional Extras	32
	EasyClean™ Pressure System	17		Seal Support Systems Order Coding Guide	34
	FDU™	18		New Stock Code Explanation	35

Company Overview

AESSEAL® is a leading global specialist in the design and manufacture of mechanical seals, bearing protectors and seal support systems.

The company sets new standards in reliability, performance, service and cost. Service has been the key to the success of AESSEAL® and is at the core of the company purpose statement — **‘to give our customers such exceptional service that they need never consider alternative sources of supply.’** Through continuous investment, unique modular technology and an unparalleled dedication to customer service we aim to constantly exceed expectation.

Customer Focus

“We aim to deliver a customer experience that surpasses expectation and truly redefines what the world expects from their sealing specialist.”

Simplicity. Our modular technology means a streamlined ordering process.

Customer-centric. Our people are encouraged to champion the customers' cause.

Ethical and Responsible. AESSEAL® has been recognized as a Climate Change Champion and has won awards for corporate social responsibility and sustainability.

Partnership. We work with customers to deliver added value and long-term reliability solutions.

Investment. Over 7% of annual sales revenue has been reinvested in R&D over several decades. This has almost certainly led to the most advanced range of sealing technology available globally.

Engineered Excellence

AESSEAL® offers a wide range of innovative and modular seal support system's to complement its mechanical seal designs.

We have invested thousands of man hours reviewing the latest legislation and design codes delivering clarity and assurance.

We believe we are the only manufacturer to supply CE certified assemblies without the use of third-party sources.

The AESSEAL® Global Technology Centre is certified to Module D, B1 and H1 — H1 being the highest level of Pressure Equipment Directive PED 2014/68/EU certification.



Water Management Technology

AESSEAL® saves 6.3 Million Litres / 1.7 Million US Gallons of water per pump per year...

This is an enormous contribution to global water conservation and clearly displays the environmental focus of AESSEAL®. The company thanks its customers for contributing to this achievement and for their promotion and installation of water management systems. The water savings are a direct result of the support and dedication of customers in using reliability focused sealing solutions. AESSEAL® looks forward to continuing its work with customers to generate even greater water savings!



Before AESSEAL® solution



After installing AESSEAL® double seal and tank system

“Of all the worlds water 97.4% is salt water, 2% is solid in ice caps and only 0.6% is suitable for industrial use and human consumption.”





The Complex Made Simple

With its innovative approach to design, the AESSEAL® Complex Systems Division has introduced modularity and repeatability to what is, for some, an uncertain manufacturing process.



The Complex Systems Division's team encompass design, fabrication, engineering and customer service to guarantee a seamless flow from inception through to specification and the delivery of truly beautiful quality products such as the Plan 53B system depicted.

CE certification for full assembly

We believe that we are the only manufacturer to fully CE certify the entire assembly.

Global

Customer service is provided from 230 locations in 104 countries, including 9 manufacturing and 58 repair locations, with more than 300 customer service representatives who visit industrial plants every day.

The systems division at AESSEAL® supplies seal support systems to all global locations with the same focus on customer service.

API 53B system designed in accordance with API 682

Industry Expertise

The AESSEAL® modular seal support system range has evolved from application experience in industry's most challenging environments. This means we have a proven, reliable system for you equipment

Please contact your local AESSEAL® representative to discover more about proven seal support solutions.



Oil & Gas



Pulp & Paper



Power Generation



Food & Beverage



Chemical & Pharmaceutical



Water & Waste Water



Bio / Ethanol



Automotive



Mining & Minerals



Metal Processing



API Piping Plans and Certification Made Easy

API icons – To make the selection of a seal support system easier AESSEAL® has designed a number of API icons so that a customer is able to link products to specific API Piping Plans.

The company has developed an API Piping Plan booklet as a guide. Examples of how the API Plans are displayed in this booklet are shown below:

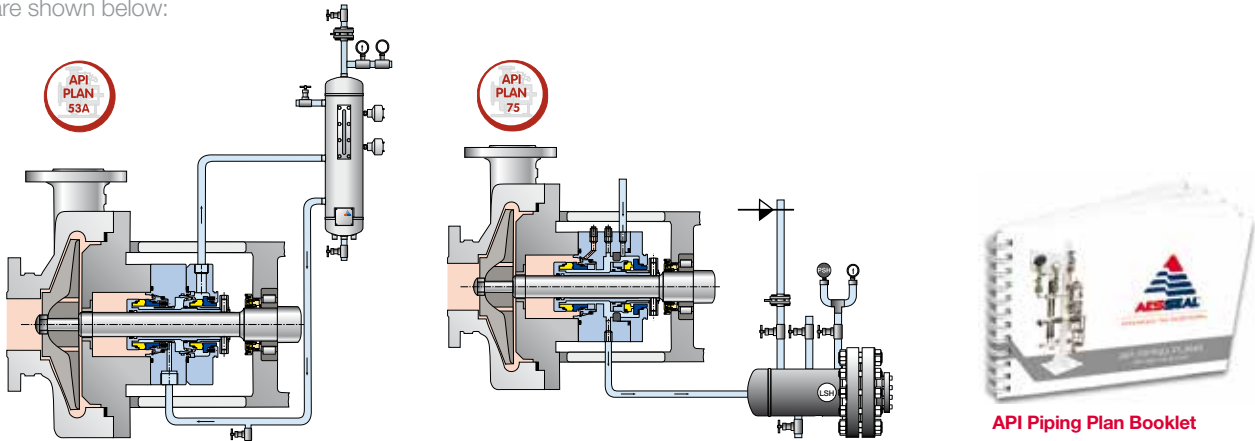

European Legislation PED 2014/68/EU

The Pressure Equipment Directive was adopted on the 29th May 1997 and came into force on the 29th November 1999.

The Directive covers pressure equipment and assemblies with a maximum allowable pressure greater than 0.5 bar. Pressure equipment means vessels, piping, safety and pressure accessories. Assemblies mean several pieces of pressure equipment assembled to form an integrated, functional whole.

General requirements are as follows:

- They are safe
- The essential safety requirements covering design, manufacture and testing are met.
- They satisfy appropriate conformity assessment procedures
- They carry the CE mark

Equipment is classified either as SEP i.e. Sound Engineering Practice or classified in categories 1 to 4. The higher the category the greater the hazard and more demanding are the requirements. Products categorized under 2, 3 or 4 require third party notified body approval which are appointed by a member state.



Certification

The PED was transposed into UK law by the Pressure Equipment Regulations (PER). Failure to comply with the PER can result in the following:

- Such equipment cannot legally be placed on the market or put into service in the UK or the European Community or EEA
- Could result in prosecution and penalties on conviction of a fine, imprisonment or both

Notified body approval - All AESSEAL® pressure vessels and assemblies are examined and certified (EC design examination certificate see Figure 2) by a third party notified body.

The quality management system for manufacture is also examined and certified by a third party notified body.

ASME VIII Div.1 - The American Society of Mechanical Engineers is an internationally recognized organization. The International Boiler and Pressure Vessel Code states the rules of safety for governing the design, fabrication and inspection of boilers and pressure vessels during construction.

All AESSEAL® vessels are designed and manufactured to the latest standard which is updated every three years. All of the company's welders are fully coded to EN 287-1 and ASME IX.



Figure 1



Figure 2

The Importance of Fluid Film

A single mechanical sealing device incorporates two flat faces, one fixed and one rotating, running against each other with a liquid film between them providing lubrication.

This liquid film is commonly known as the fluid film. Without a stable fluid film between the faces they would be in full contact causing frictional heat build up and dry running, leading to excessive wear and component damage (Image 1). The key to successful sealing is the maintenance of a cool, clean and stable fluid film between the sealing faces (Image 2). This very thin, 2 - 3 micrometre, fluid film can be difficult to maintain and this is the primary challenge when sealing a pump application.

If a single mechanical seal is used then the process fluid becomes the fluid film. As long as the process fluid is an acceptable lubricant, is at an acceptable temperature and is not a dangerous substance, a single seal can be used.

Many process liquids are not, however, acceptable for cooling and lubricating the seal faces (Image 3). These fluids fall into the following categories:

- Slurries
- Hot liquids that can evaporate as the pressure drops across the faces
- Cold liquids that can become very viscous or solidify
- Liquids that crystallise as they contact atmospheric conditions
- Liquids that coke as they contact atmospheric conditions
- Liquids that leave a film or a deposit across the seal faces due to the heat generated between the faces

All of the above conditions require a double mechanical seal with an external barrier fluid between the two sets of seal faces. The external barrier fluid must be at a higher pressure than the sealing chamber pressure to drive the clean, cool barrier fluid across the inboard seal faces rather than allowing the process fluid to cross the faces (Image 4).

Reliability Enhancement

In April 2007 research was finalized on 11,000 mechanical seal failures recorded by all manufacturers worldwide over the previous two years. The results highlighted that inadequate seal support systems contributed to 22% of these failures. AESSEAL® technical support staff will recommend a reliable seal support system for your applications and remove this 22% failure risk.



1. Dry running seal



2. Fluid film cooling the seal faces



3. Slurry at the seal faces



4. Double mechanical seal with cool / clean barrier fluid

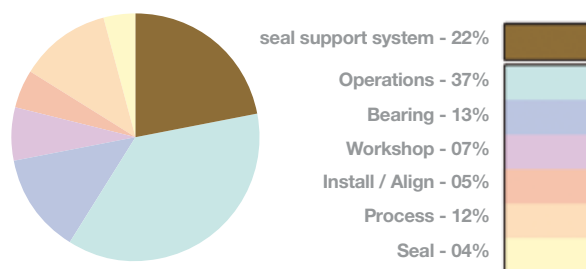

Source: Stephen Flood, Performance Plus Ltd - "Mechanical Seal Reliability - What Realistically can Be Achieved?" presented at The Mechanical Sealing Technology Seminar, I Mech E, London, April 07

Barrier Fluid Choice

Water Barrier Fluid

In general water is the most readily available barrier fluid for cooling mechanical seal faces. Traditionally a quench to drain arrangement is used in industry to provide a higher pressure water barrier fluid to a double mechanical seal. This arrangement removes a significant amount of heat from the double mechanical seal but it has major pitfalls.

Operational demands in a plant impact upon the available pressure in the plant water line and can make it unstable. This will interrupt the pressure and or supply of the water barrier fluid to the double mechanical seal and allow damaging process liquids to come back across the seal faces. The other issue is that the water exiting the seal is often sent to the drain, meaning there is both a cost to purchasing and to treating the water which will either return to the seal water ring main system or to its original source.

A double mechanical seal running quench to drain can use 1.7 million gal (US) / 6.3 million litres of water annually per pump application so the cost implications can be significant.

The AESSEAL® systems division has designed a range of seal support systems known as water management systems which provide a reliable water barrier fluid. Water will thermosyphon or convect which means the hotter, lower density water will rise while the cooler water sinks. Therefore, with water as a barrier fluid, the warm water will radiate heat from the seal through the system vessel to atmosphere and allow the colder water to move to the bottom of the vessel to be supplied to the mechanical seal (Figure 1).

A water management system will significantly increase the Mean Time Between Failure (MTBF) of the mechanical seal and in doing so increase plant uptime. The environmentally friendly systems can reduce annual water consumption from 1.7 million gal (US) / 6.3 million litres, to 8.5 gal (US) / 32 litres. Therefore the systems significantly reduce or totally remove water consumption and costs.



Figure 1

Oil Barrier Fluid

If the application prohibits the use of a water based barrier fluid then an oil based barrier fluid is often used. In comparison to water, oil based barrier fluids are less inclined to circulate (indeed some will not circulate at all). If the oil is not moved it could overheat at the mechanical seal and coke on the faces. In this situation a number of options are available:

- **A Pumping ring** — (e.g. the AESSEAL® DMSF™ double mechanical seal) can be used to move the oil through the seal more effectively when a seal support system is being used
- **An in-line circulation pump** — can be used to circulate the oil barrier fluid to and from the seal
- **An API Plan 54 arrangement** — such as an Oil PUMPPAC™ system can be used. This is a forced circulation system used to circulate the oil barrier fluid to and from the mechanical seal

As shown in Figure 2, an external gas source may be required to pressurise the oil barrier fluid to the necessary 1 bar / 15 psi above seal chamber pressure. This is usually supplied by an external compressed nitrogen gas supply

AESSEAL® offers a wide range of oil support systems that can supply a reliable oil barrier fluid to the mechanical seal to give greater seal life and improve reliability.



Figure 2

Gas Barrier

As an alternative to water or oil based barrier fluids an inert gas can be used. A pressurised gas supply will be fed between the faces of the mechanical seal to provide a clean barrier. Once the gas has passed between the seal faces it will be consumed by the process.

Nitrogen will normally be used as the gas barrier. The AESSEAL® Gas Panel seal support system (Figure 3) was designed to supply the gas barrier to the seal. The Gas Panel used in conjunction with the AESSEAL® UDGS™, Mixmaster™ or Clip™ seal range forms an efficient and reliable seal support system on gas barrier applications. These applications are particularly common in the Chemical and Pharmaceutical markets where water or oil barrier fluid contamination of the process is unacceptable .



Figure 3

Water Management Systems

The AESSEAL® water management system range connects to the plant water line to feed the mechanical seal with a clean, cool and stable water barrier fluid.

Water management systems are self replenishing and pressurising, being able to regulate down the pressure available in the plant water line. This is a reliable and cost saving seal support system method for a number of reasons:

Increase Plant Uptime & Mean Time Between Failure (MTBF)

The Water Management system range reduces equipment downtime by increasing the MTBF of the mechanical seal.

Reduce Water Usage and Costs

Traditional quench to drain and flush seal support methods waste huge quantities of water (up to 1.7 million gal (US) / 6.3 million litres of water per seal application per year). Water management systems reduce this water consumption to as little as 8.45 gal (US) / 32 litres per seal application per year. This is a massive saving that will reduce water purchase and effluent treatment costs.

Fast Return on Investment (ROI)

The reduction in down time and water / energy / operator costs means that there is a typical ROI when installing an AESSEAL® Water Management system and mechanical seal of approximately 6-9 months.

Environmentally Friendly

The reduction in the use of water and energy means that water management systems will make the customer's manufacturing process more environmentally friendly and reduce your carbon footprint.

Reduce Operator Costs

Water management systems are largely maintenance free and free up operator / maintenance resources for other areas of the plant.

Reduce Energy Usage and Costs

Water Management systems restrict the amount of water migrating across the seal faces into processes that require evaporation during the manufacturing process.

AESSEAL® water management systems save in excess of 25 billion US gallons / 95 billion litres of water for customers each year.

Water Technology Ladder

The water technology ladder shows the progression of technology within the company's water management system range.

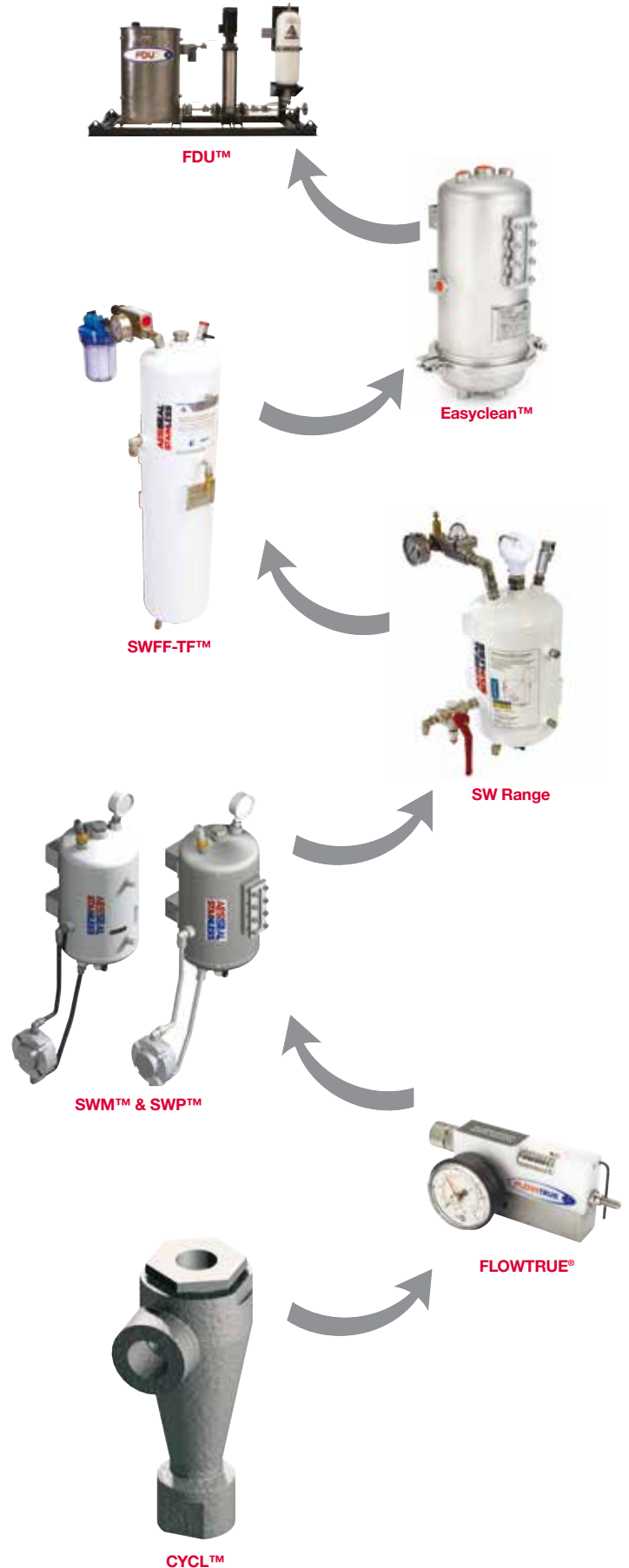

Cyclone Separator

The CYCL™ (Cyclone Separator) is designed to separate heavy particles from the product liquid.

The clean fluid can be used as flush liquid, improving conditions at the seal faces. The separated particles drain back into the sealed product. The benefit is a reliable and low cost sealing system for heavy product particle applications which does not require an independent flush supply.

CYCL™ - Operation

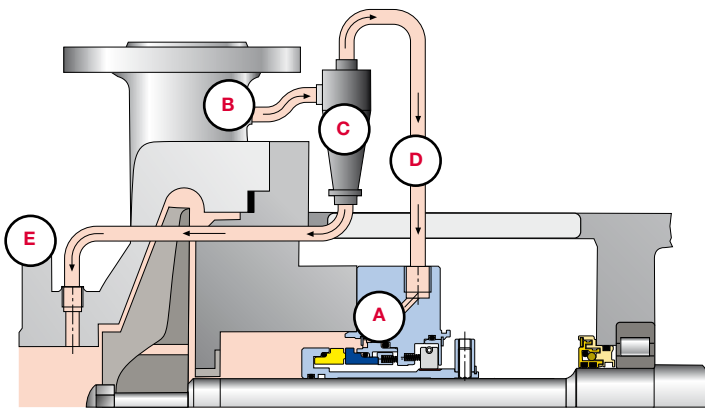

**AESSEAL® CYCL™
Cyclone Separator**

Item	Description
A	Mechanical seal
B	Dirty product liquid pressure feed
C	Cyclone separator
D	Clean product liquid (Mechanical seal flush fluid)
E	Dirty product liquid return to pump suction

CYCL™ - Items and Sizing

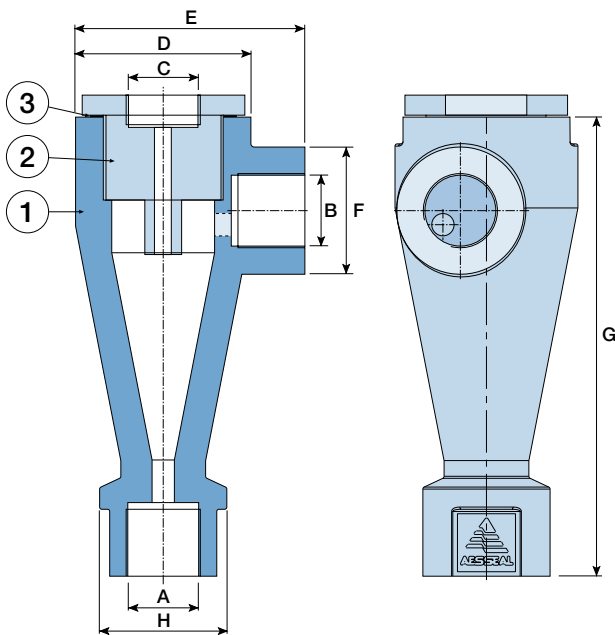

CYCL™

Parts List

Item	Description
1	Cyclone separator body
2	Hex. reducing bush
3	Dowty washer

CYCL™

Key interface dimensions, mm (inches)

Style	Ø A, B, C	Ø D	Ø E	Ø F	Ø G	Ø H
316 SS Duplex	1/2" NPT	46mm 1.89"	66mm 2.60"	35mm 1.38"	118mm 4.65"	35mm 1.38"
316 SS Duplex	1" NPT	82mm 3.20"	106.5mm 4.09"	57mm 2.20"	220mm 8.7"	57mm 2.20"

FLOWTRUE®

The AESSEAL® FLOWTRUE® is a robust and adjustable flow meter that controls the amount of water flowing to the mechanical seal for cooling purposes.

The unique and advanced FLOWTRUE® design means that of all the flow meters available it is the least likely to clog. This is due to large internal clearances within the design. There are three models of the FLOWTRUE® available, which enable the product to be used on packing applications, single seals and double mechanical seals.

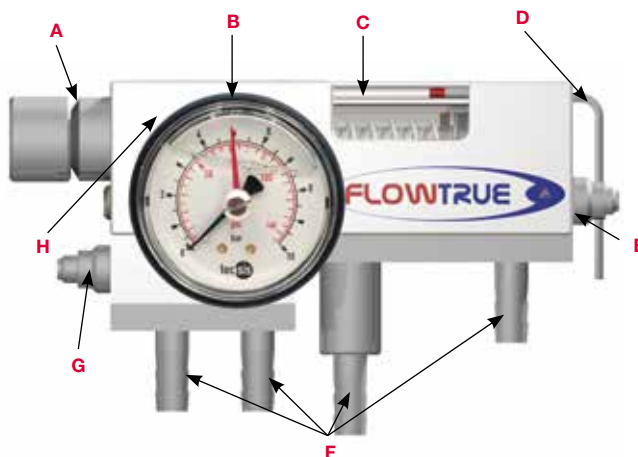

Features	Benefits
Flow cartridge design	Cartridge has a tapered design which gives larger clearances. This means that it is less likely to clog than competitor models
Unique segmental valves	There are larger clearances within the FLOWTRUE® flow control valve. This means that it is less likely to clog than competitor models
Innovative flow tube cleaning mechanism	FLOWTRUE® can be cleaned without interrupting flow or pressure
Integrated non-return valve	Protects the plant water supply from product contamination
Modular design	Ensures that the FLOWTRUE® can be easily upgraded and repaired
Flow and pressure controls can only be adjusted by using an allen key	Restricts the opportunity for accidental adjustment of flow or pressure by operators

Label	Description	Purpose
A	Cartridge assembly	The heart of the system, also contains the cleaning function
B	Pressure gauge	Indicates the pressure of the water at the mechanical seal (double seal models only)
C	Flow channel	Gives details of the flow of water through the FLOWTRUE®
D	Valve adjustment key	Used to adjust the flow and pressure control valves
E	Flow control valve	Controls the volume of water flowing through the FLOWTRUE®
F	Water connections	Connects the FLOWTRUE® to the mechanical seal and water feed
G	Pressure control valve	Controls the pressure of the water at the seal (double seal models only)
H	Polyacetal standard white body material	Maximum temperature 80°C / 176°F, maximum pressure 25 bar / 360 psi

FLOWTRUE® Product Range



FT - FLOWTRUE® for packing and single seals (push on connections).



FTP - FLOWTRUE® with pressure gauge for packing and single seals (push on connections).



FTPB - FLOWTRUE® with pressure gauge and back pressure control valve for double mechanical seals (push on connections).



FT-SC - FLOWTRUE® for packing and single seals (screwed connections).



FTP-SC - FLOWTRUE® with pressure gauge for packing and single seals (screwed connections).



FTPB-SC - FLOWTRUE® with pressure gauge and back pressure control valve for double mechanical seals (screwed connections).



FLOWTRUE® Selection Guide

Below are five steps to follow in order to select a FLOWTRUE®.

Optional extras are ordered as separate items.

STEP 1 - Selection of base model

FLOWTRUE® Base Model	(Code)
For use with packed glands and single seals without pressure gauge	FT-XX
For use with packed glands and single seals with pressure gauge	FTP-XX-YYY
For use with double mechanical seals, with pressure gauge, with back pressure valve	FTPB-XX-YYY

STEP 2 - Selection of flow range

Flow Range	(XX)
0.1 - 0.4 gpm (0.5 - 1.5 l/min)	04
0.2 - 0.8 gpm (0.5 - 3.0 l/min)	08
0.25 - 2.0 gpm (1.0 - 8.0 l/min)	20
1.0 - 4.0 gpm (2.0 - 15 l/min)	40

STEP 3 - Selection of pressure range

Pressure Gauge Range	(YYY)
No gauge	
0 - 145 psi (0 - 10 bar)	145
0 - 360 psi (0 - 25 bar)	360

STEP 4 - Selection of main body material

Material	Max Temperature	Max Pressure	Coding
Polyacetal (standard)	80°C (176°F)	25 Bar (360 psi)	
Polyethylene	60°C (140°F)	10 Bar (145 psi)	PE

STEP 5 - Selection of connections

Connection	Coding
10mm Push-on (standard)	
Screwed connections 1/4" NPT	SC

Optional Extras

Stock Code	Description
FLOWTRUE® mounting options	
FT-BRKT	Mounting bracket for push on connection models, Stainless Steel
FT-BRKT-SC	Mounting bracket for screwed connection models, Stainless Steel
FT-STAND	Floor mount stand, 316 Stainless Steel

Inductive Alarm	
FT-ALARM-AC250	AC 20-250 volts
FT-ALARM-DC55	DC 10-55 volts

Hose kit for push-on connection models	
FT-HSK-FT	1 off 3/8" (10mm) ID Hose x 5ft (1.5m) & SS seal fittings - FT & FTB model
FT-HSK-FTPB	2 off 3/8" (10mm) ID Hose x 5ft (1.5m) & SS seal fittings - FTPB model

Hose kit for screwed connection models	
FT-HSK-FT-04	1 off 1/2" OD Hose x 5ft (1.5m) & 2 SS compression fittings & 1 SS seal fitting
FT-HSK-FTPB-04	2 off 1/2" OD Hose x 5ft (1.5m) & 4 SS compression fittings & 2 SS seal fittings
FT-HSK-FT-12	1 off 12mm OD Hose x 5ft (1.5m) & 2 SS compression fittings & 1 SS fitting
FT-HSK-FTPB-12	2 off 12mm OD Hose x 5ft (1.5m) & 4 SS compression fittings & 2 SS seal fittings

Order Example - FLOWTRUE® with back pressure valve, with pressure gauge for double seals, 0.2-0.8 gpm, 0-360 psi, Polyacetal body, Threaded connections = FTPB - 08 - 360 - SC.

Order Example - FLOWTRUE® without pressure gauge, for single seals, 0.1-0.4 gpm Polyethylene body, Push-on connections = FT - 04 - PE.



SWM™ & SWP™

The SWM™ (System Water Management) & SWP™ (System Weld Pad) are closed loop water management systems.

These systems operate at the maximum pressure available in the plant water line (i.e. if the plant water line pressure is 45 psi / 3 bar the pressure of the barrier fluid in the tank will be the same). A check valve is supplied as part of the system, which ensures that the plant water line does not become contaminated with process and also ensures that the barrier fluid pressure remains at the maximum available from the plant water line even if the water line pressure fluctuates (e.g. if a plant operator uses a hose and reduces the plant water line pressure, the barrier fluid pressure in the SWM™ or SWP™ is not effected). Barrier fluid is circulated from the system to the seal and back to the system via the thermosyphon effect (see operating principle below). **The SWP™ system incorporates a robust weld pad level gauge (SWP™ only) which allows an industrially acceptable visual indication of barrier fluid level.**

Maximum Set Pressure: 6 barg / 87 psig

Maximum Design Pressure: 10 barg / 145 psig

Maximum Temperature: 80°C / 176°F (with suitably rated piping / hosing)

Minimum Temperature: 0°C / 32°F

Features	Benefits
304 SS vessel construction	Suitable for a range of challenging environments
Non-return valve	Protects plant water supply from potential contamination and maintains vessel pressure in the event of supply interruption
Weld pad level gauge (SWP™ only)	Robust and industrially acceptable visual indication of barrier fluid level

Label	Description	Purpose
A	Check valve	Protects against process entering the plant water line and protects the barrier fluid pressure against fluctuations in plant water line pressure
B	Pressure gauge	Displays the barrier fluid pressure in the system
C	Weld pad level gauge (SWP™ only)	Visual indication of barrier fluid level in the vessel
D	Vessel - (304 SS construction, 10 litre / 2.64 gal (US) capacity (SWM™), 12 litre / 3 gal (US) weld pad type (SWP™), 80°C / 176°F temperature limit)	Dissipates the heat from the barrier fluid to atmosphere
E	Drain valve	Drain barrier fluid from the system
F	Mechanical seal feed and system return lines	Supplies barrier fluid to the mechanical seal and back to the system
G	Mechanical seal	Not supplied as part of the SWM™ or SWP™ systems
H	Mounting brackets	Securely mounts the SWM™ or SWP™ systems

*Protection against freezing required for water below 0 °C

Operating Principle

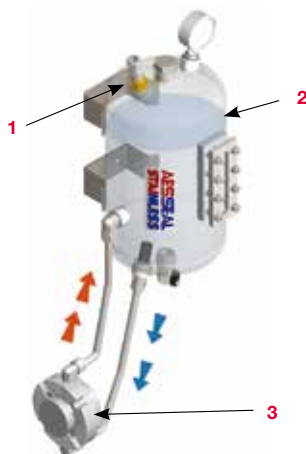

1. Water from the plant water line enters the system.
2. Barrier fluid pressure will be the maximum pressure available from the plant water line.
3. The barrier fluid is circulated to the seal and back to the system by the thermosyphon effect.

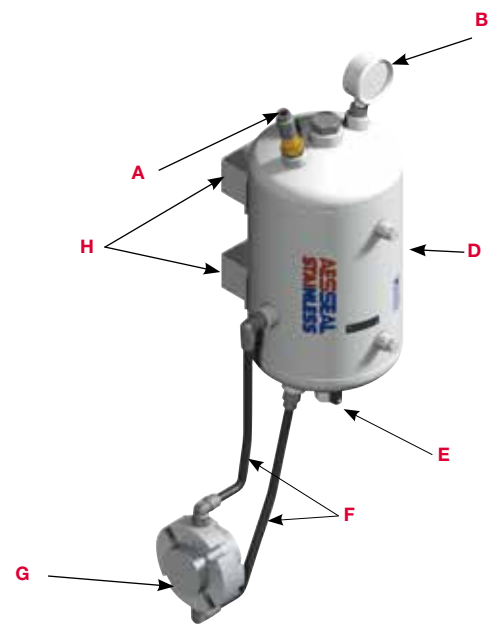

SWM™ System

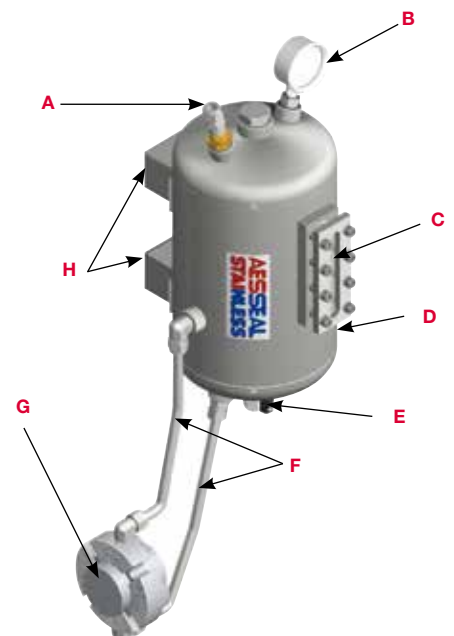

SWP™ System



SW Range

The SW Range consists of the SW2™ and SW3™ water management systems.

The environmentally friendly SW Range systems connect directly to the plant water line. Using the pressure regulator supplied, the plant water line pressure can be adjusted so that the systems barrier fluid pressure is set at 1 bar / 15 psi above stuffing box pressure. The flow indicator allows a visual indication of mechanical seal upset or failure. The SW3™ is supplied with finned tubing as standard so that it can be used on high heat applications. Barrier fluid is circulated to and from the mechanical seal via the thermosyphon effect.

- Maximum Set Pressure: 6 barg / 87 psig
- Maximum Design Pressure: 10 barg / 145 psig
- Maximum Temperature: 80°C / 176°F (with suitably rated piping / hosing)
- Minimum Temperature: 0°C / 32°F

Features	Benefits
304 SS vessel construction	Suitable for a range of challenging environments
Water regulator	Maintains vessel water level and pressure
Flow indicator	Visually alerts the user of an inboard seal failure
Non-return valve	Protects plant water supply from potential contamination and maintains vessel pressure in the event of water supply interruption
Supplied as a complete system	The SW Range have all the components necessary for fast and easy installation

Label	Description	Purpose
A	Pressure gauge (Brass)	Displays the pressure of the barrier fluid in the SW2™ system
B	Non-return valve (Brass)	Protects plant water supply from potential contamination from the process. Protects the barrier fluid from pressure fluctuations in the plant water line
C	Pressure regulator (Brass, Max outlet pressure 10 bar / 150 psi)	Regulates the plant water line pressure so it can be set at 1 bar / 15psi above stuffing box pressure. Automatically replenishes lost water and re-sets barrier fluid pressure if there is a mechanical seal upset
D	Flow indicator (SS)	Provides a visual indication of a mechanical seal upset (White ball will become visible)
E	Vessel- (304 SS Construction 10 litre / 2.64 gal (US) capacity, 25 litre / 6.60 gal (US) option, 80°C / 176°F temperature limit)	Dissipates the heat from the barrier fluid to atmosphere
F	Drain valve (Nickel plated Brass)	When this is opened it cleans out any sediment at the bottom of the vessel. When it is closed again the pressure regulator will replenish any water lost and bring the SW2™ back up to pressure
G	Mechanical seal feed and return lines	Supplies barrier fluid to and from the mechanical seal
H	3-way valve (SW2™ only Brass)	Enables the flushing of the seal for cleaning purposes. Is also the point where barrier fluid returns to the System
I	Mounting brackets	Securely mounts the SW Range

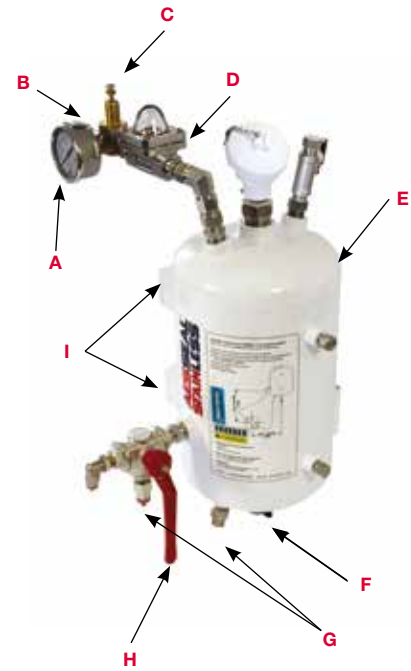

SW2™ Water Management System

Operating Principle



1. Water from the plant water line enters the system.
2. The pressure of the barrier fluid in the vessel can be regulated via the pressure regulator
3. The barrier fluid is circulated to the seal and back to the system by the thermosyphon effect.



SW3™ Water Management System



SWFF-TF™

The intelligent SWFF-TF™ system incorporates the Flow Fuse™ and Thermal Fuse™ products:

The Flow Fuse™ is designed to restrict barrier fluid contamination of the process upon momentary or permanent seal failure. The Flow Fuse™ does this by isolating the seal support system from the plant water supply when it detects an abnormally high flow of water. The Flow Fuse™ product has two operating functions. These are manual-reset and auto-reset. In manual-reset the Flow Fuse™ will completely isolate the plant water supply upon the detection of seal failure and the only way to reset the Flow Fuse™ is manually. This mode is most suited to applications where barrier fluid contamination of the process cannot be tolerated. In auto-reset mode, upon seal failure the Flow Fuse™ will shut off the plant water supply but allow a small volume of water to continue to pass through. If the seal failure is momentary (e.g. temporary parting of the seal faces) the Flow Fuse™ will automatically reset itself to the original operating pressures once the seal failure has been resolved. **The Thermal Fuse™ is a pressure relief valve designed to relieve the system of pressure build up as a result of a temperature increase.**

Maximum Set Pressure: 6 barg / 87 psig

Maximum Design Pressure: 10 barg / 145 psig

Maximum Temperature: 80°C / 176°F (with suitably rated piping / hosing)

Minimum Temperature: 0°C / 32°F

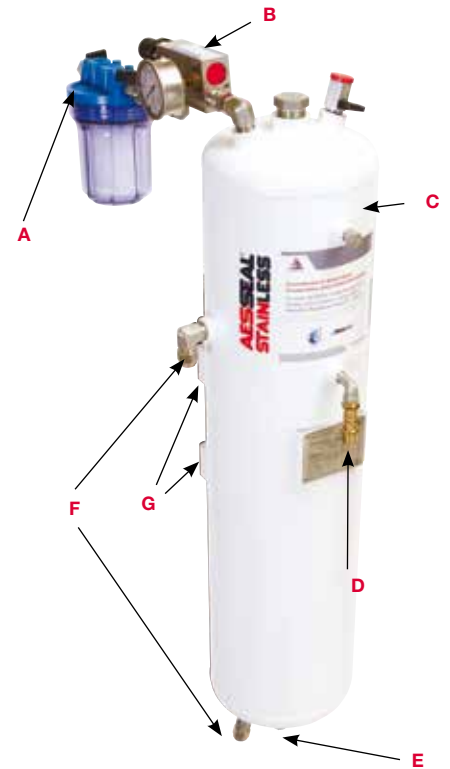

Features	Benefits
Flow sensing shut off valve	Protects the process from barrier fluid contamination upon catastrophic seal failure
Water regulator	Maintains water level and pressure, which reduces due to normal seal operation
Automatic reset facility	Protects the mechanical seal from running dry during process up-sets
Thermal relief valve	Maintains systems pre-set pressure by accommodating any thermal expansion

Label	Description	Purpose
A	In-line filter (1 micron)	Cleans plant water before it fills the vessel
B	Flow Fuse™ (Nickel plated Brass construction)	Heart of the SWFF-TF™ system
C	Vessel - (304 SS construction 10 litre / 2.64 gal (US) capacity, 25 litre / 6.60 gal (US) option 16 bar / 232 psi pressure limit 80°C / 176°F temperature limit)	Dissipates the heat from the barrier fluid to atmosphere
D	Thermal Fuse™ (Brass)	Will relieve the system of excess pressure build up as a result of a temperature increase
E	Drain valve (Nickel plated Brass)	Drains any sediment from the SWFF-TF™
F	Seal feed and return lines	Carries barrier fluid to and from the mechanical seal
G	Mounting brackets	Provides a secure and stable mounting for the SWFF-TF™ system
H	Pressure regulator	Regulates the plant water line pressure to 2 bar / 30 psi above seal chamber pressure
I	Activation indicator and manual reset button	When the red button moves outside the Flow Fuse™ casing it shows that it has been activated. The button needs to be pushed in to refill the vessel in manual reset mode
J	Automatic reset adjusting screw	When screw is fully screwed in the Flow Fuse™ will be in manual reset mode. When it is screwed out it will be in auto reset mode
K	Flow Fuse™ vessel inlet	Is the point where the Flow Fuse™ connects to the system vessel
L	Integral check valve	Protects the plant water supply from potential contamination from the process
M	Plant water inlet	Is the point where the plant water line is connected to the Flow Fuse™

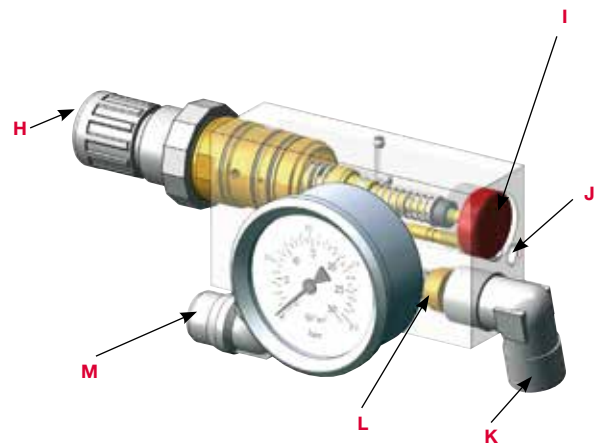

EasyClean™ Pressure Systems

Pressure Systems Designed for the Pharmaceutical, Food & Beverage Sectors. EasyClean™ can be used as part of an API Plan 52 and 53A seal support systems.

Designed for industries where it is important to ensure that all machinery is maintained to a high standard of cleanliness. Potential issues with existing mechanical seal support systems using sealed vessels (e.g. Plans 52, 53A):

- Have the potential to harbour and breed bacteria
- Difficult to clean as a result of restricted access
- Difficult to inspect

Eliminate these issues with a cost effective solution!

EasyClean™ includes all the features of the standard vessels plus has the added benefit of being supplied with a quick release clamp, allowing the bottom section of the vessel to be removed for cleaning and inspection. These additional features make it ideal for applications that require more control and a higher level of cleanliness.



Features	Benefits
Customer effective solution	Simple patented design solving critical issues in applications requiring higher standards of cleanliness
Fully accessible	Quick release clamp allows vessel to be opened for cleaning and inspection
304 Stainless Steel construction	Ideal in Pharmaceutical and Food & Beverage industries

The AESSEAL® modular design allows for this vessel to be supplied in SW or SP arrangement.

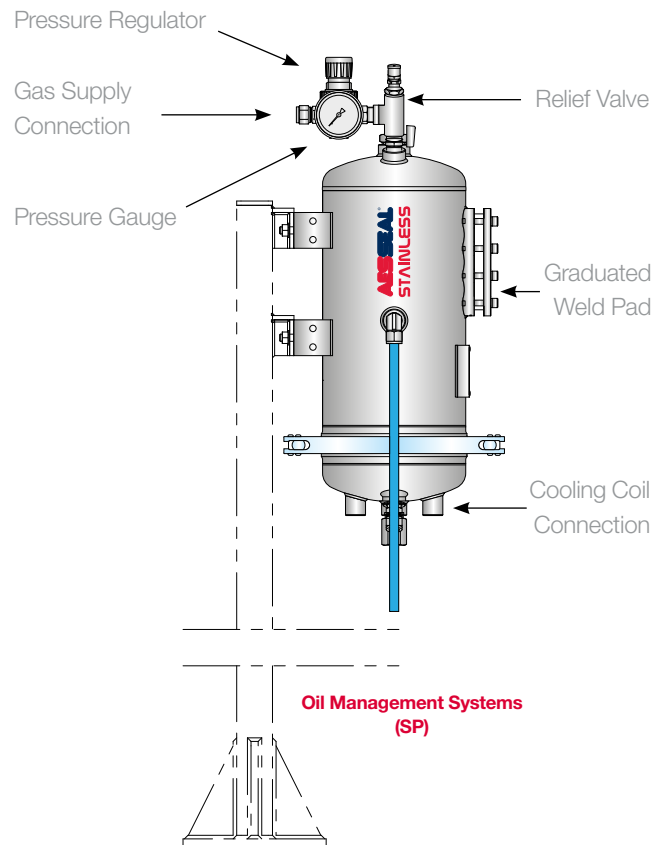
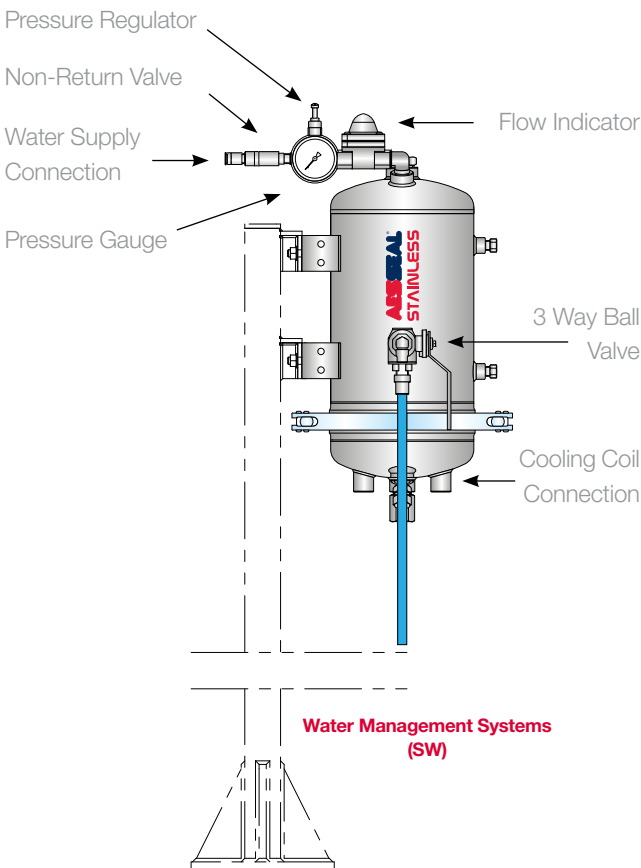

FDU™ Auto Top Up & Plan 54

The AESSEAL® FDU™ (Fluid Distribution Unit) is an efficient and high performance forced circulation PUMPPAC™ system.

The product was developed to meet the requirements of the API Plan 54 Piping Plan, which maximizes heat dump potential for more arduous pump applications. The FDU™ is adaptable to a wide range of industry applications with the fitting of additional equipment (optional: accumulator, level switch / transmitter and pressure switch / transmitter). Please note that both oil and water can be used with the FDU™.

Max Assembly: 16 barg (232psig)

Max Temperature: 80°C / 176°F

Features	Benefits
Independent pressurised fluid supply system	Removes the expense of piping a pressurised clean water / oil supply to a new area of the plant
Can feed a number of seal support systems	Removes the expense of purchasing one system per mechanical seal
Optional pressure switch and accumulator	Enables greater control of water / oil line pressure from the FDU™
Reduced energy consumption	The system can be operated intermittently to reduce energy costs via dead-ended piping

Label Description	Purpose
A Motor (three phase, cast iron housing, 50/60hz, IP55)	Drives the pump
B Filler cap (plastic, breather type)	Manual filling point for tank
C Float control valve	Re-fill mechanism for tank
D Tank (304SS, 180 litre / 48 gal (US) capacity)	Large volume ensures ample barrier fluid supply
E Optional level switch	Warns of low barrier fluid level in tank
F Pump (vertical multistage centrifugal, cast iron head, 316SS wetted parts, 16.6 litre / 4.4 gal (US) or 5 litre / 1.3 gal (US) capacity options)	Pumps barrier fluid to systems
G Platform (Carbon Steel, powder coated)	Platform for all FDU™ components
H Optional accumulator (bladder type, body carbon steel, 20 litre / 5.3 gal (US) capacity)	Holds pressure in top up arrangement
I Pressure gauge (0-20 bar / 0-300 psi)	Displays the barrier fluid / top up pressure
J Optional pressure switch	Warns of drop in barrier fluid / top up pressure

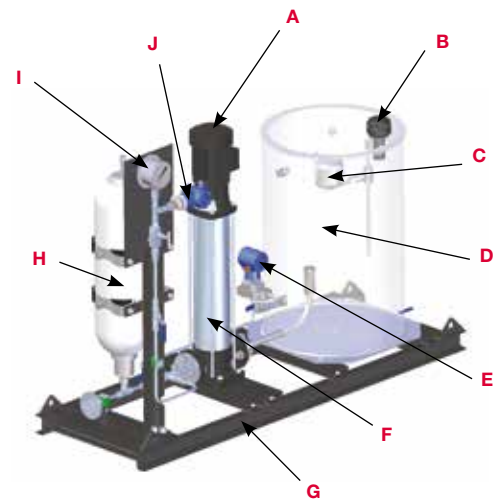

Operating Principle

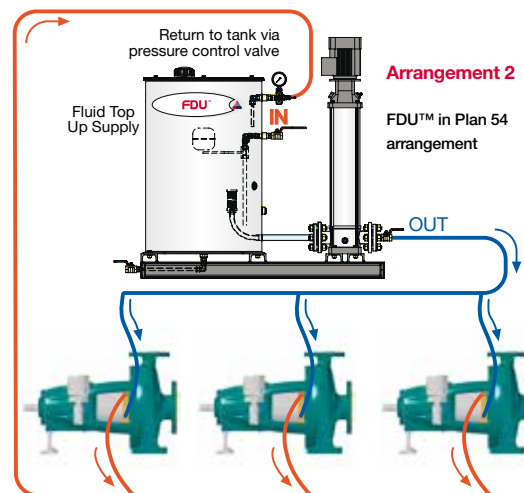
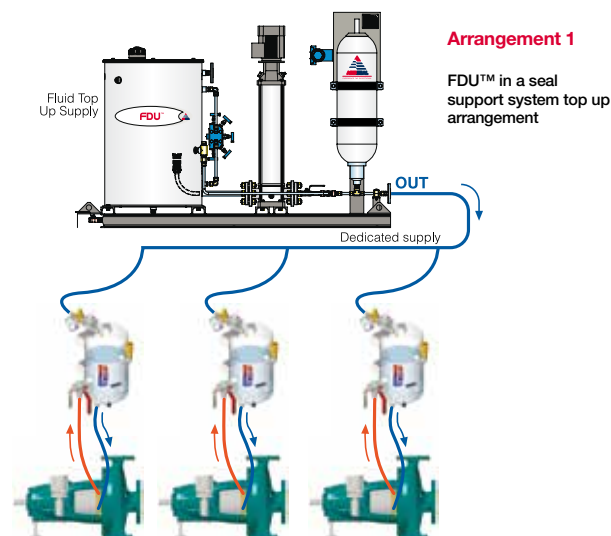

The diagram to the left illustrates how the FDU™ can supply multiple seal support systems. The diagram above illustrates how the FDU™ can supply multiple seals in a closed loop operation.



Oil Support Systems

AESSEAL® designs and manufactures a range of reliable and innovative oil support systems. Our vessel based systems can utilize an inert gas feed (usually nitrogen) to pressurise the barrier fluid.

Whilst all of these systems are primarily designed to be used with oil as a barrier fluid, water and oil / water mixes can also be used as a barrier fluid with a number of the systems in the oil support system range (i.e. SP Range, AES-15™, AES-FV™, AES-28™ and API Plan 53B).

Increase Plant Uptime & Mean Time Between Failure (MTBF)

The oil support system Range increases the life of sealing equipment. This reduces equipment repair and down time.

Wide Choice of Barrier Fluid

Different oils can be used as barrier fluids on all systems. Some of the systems in this section will also allow water to be used as a barrier fluid.

Increased Safety

The pressurised oil barrier fluid will stop hazardous products escaping to atmosphere.

Enhanced Lubrication for Seal Faces

Oil acts as an excellent lubricant for the mechanical seal faces.

Higher Temperature and Pressure Applications

The physical properties of oil allow it to be utilized as a barrier fluid on high temperature / pressure applications.

Oil Technology Ladder

The oil technology ladder shows the progression of technology within our oil support system range

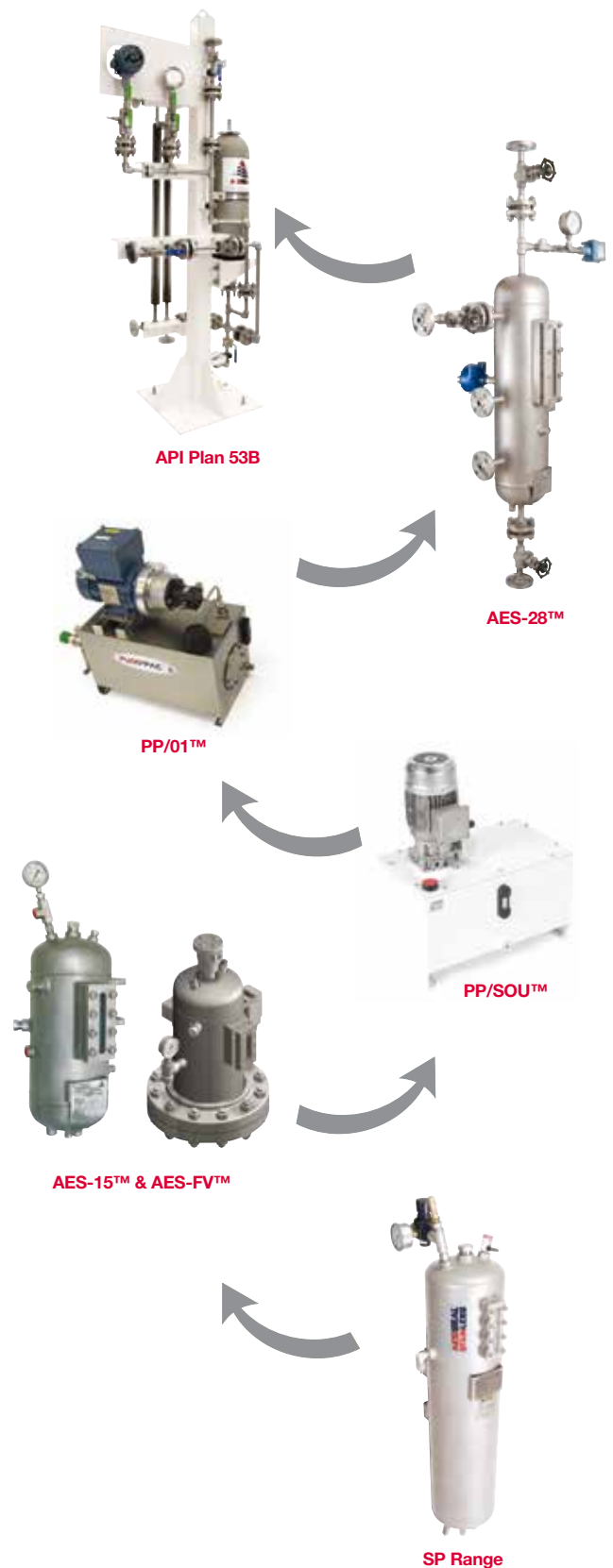

SP Range

The SP Range consists of the SP1™, SP2™ and SP3™ systems. The SP1™ is a non-pressurised buffer system modelled on the API Plan 52 Piping Plan. The SP2™ and SP3™ systems are modelled on the API 53A Piping Plan.

The SP3™ has the addition of finned tubing so that it has extra surface area to operate on high heat applications. All vessels are designed and manufactured in accordance with ASME VIII Div.1 and certified by TÜV to cover PED requirements.

Max Assembly: 10 barg (145psig)

Max Assembly: 100°C / 212°F

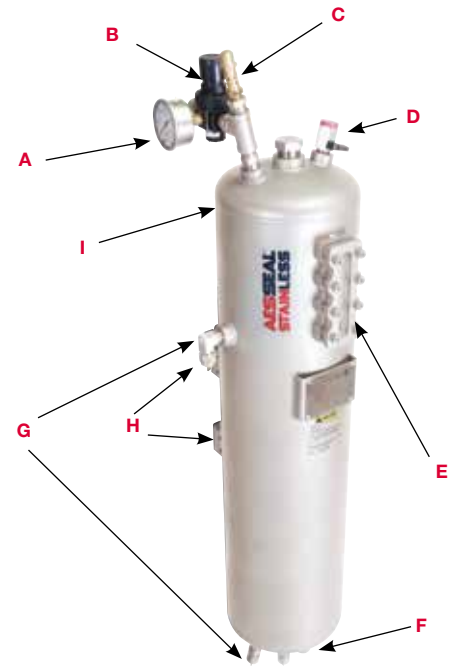

Features	Benefits
Integral 304 SS weld pad level gauge	Robust and industrially acceptable visual indication of barrier fluid level
304 SS vessel construction	Suitable for a wide range of arduous environments
Satin bead blast finish	Suitable for a wider range of industrial environments
Available with / without cooling coil	Adaptable to wider range of equipment arrangements

Label	Description	Purpose
A	Pressure gauge	Displays the pressure of the barrier fluid inside the system
B	Pressure regulator	Regulates the pressure of the inert gas source feeding the SP2™ System
C	Pressure relief valve	Protects against pressure build up in the system
D	Fill valve	Fills the vessel with barrier fluid prior to pressurisation
E	Weld pad level gauge, 304 SS construction	Gives a visual indication of barrier fluid level in the system
F	Drain valve	Can be used to drain the vessel
G	Seal feed & return lines	Carries barrier fluid to and from the seal
H	Mounting brackets	Used to mount the system so it is free from vibration and in close proximity to the seal. We recommend the use of an AESSEAL® mounting stand for mounting this system
I	Vessel (304 SS construction, 12 litre / 3 gal (US) capacity, 25 litre / 6.60 gal (US) option, 100°C / 212°F temperature limit)	Dissipates the heat of the barrier fluid to atmosphere

Operating Principle

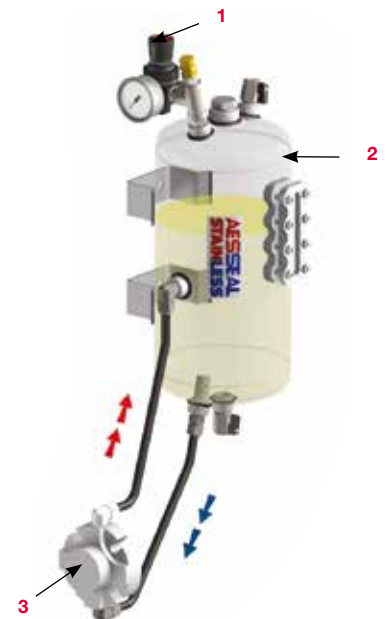

1. Gas enters the SP system through the pressure regulator.
2. Gas pressurises the barrier fluid (Oil or Water can be used with SP Range) to 1 bar / 15 psi above seal chamber pressure.
3. Barrier fluid is circulated to the seal and back to the system by the thermosyphon effect or by a bi-directional pumping ring.

SP Range

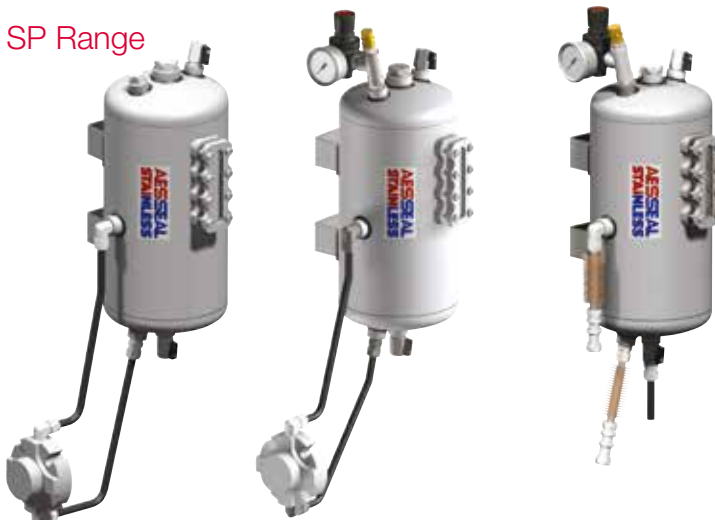

SP1™ Buffer System

SP2™ System

SP3™ System

AES-15™

The AES-15™ vessel forms the core of a robust, low maintenance and highly reliable seal support system.

The vessel is constructed from 316 stainless steel and is designed to meet the high end needs of the Chemical, Pharmaceutical and Petrochemical industries. A Cooling Coil is supplied as standard with the vessel.

The AES-15™ can operate at pressures up to 30 bar / 435 psi and temperatures up to 100°C / 212°F. Both oil and water can be used as barrier fluids with the AES-15™, ensuring its compatibility with a wide range of industrial pump applications.

Features	Benefits
316 SS vessel construction	Robust vessel suitable for a range of challenging environments
Vessels are designed and manufactured in accordance with ASME VIII Div.1 and PED 2014/68/EU	Suitable for a wide range of arduous environments. Design rating 30 bar @ 100°C / 435 psi @ 212°F
Enhanced modular design	Available in threaded as standard or flanged construction
Cooling coil as standard	Additional cooling available for high heat applications

Label	Description	Purpose
A	Vessel (316 SS 15 litre / 3.96 gal (US))	Dissipates heat of the barrier fluid to atmosphere
B	Weld pad level gauge (316 SS construction)	Visual indication of barrier fluid level in the vessel
C	Cooling coil connections (Cooling coil supplied as standard with the AES-15™)	Cooling coil provides additional cooling of the barrier fluid
D	Mechanical seal feed and AES-15™ return lines	Supplies barrier fluid to the mechanical seal and back to the AES-15™
E	Fill / vent connections	For ease of filling or venting
F	Pressure gauge (optional extra)	Displays the barrier fluid pressure in the AES-15™

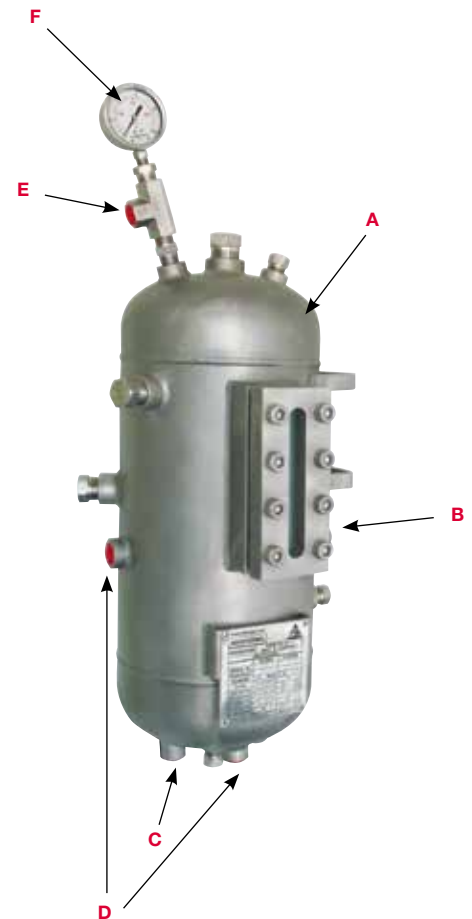

The AES-15™ system is available with a selection of ATEX certified pressure and level switches.

AES-FV™

The AES-FV™ (Flanged Vessel) can have its bottom flange easily removed to administer efficient internal cleaning

Max Assembly: 16 barg (232psig)

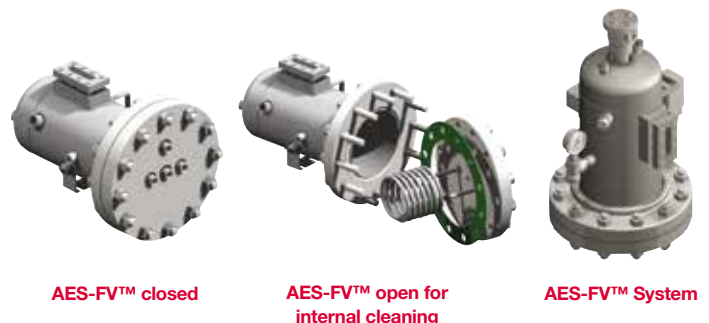

PP/SOU™

The PP/SOU™ is an entry level alternative to the standard AESSEAL® PUMPPAC™ Range.

The product is suitable for many industries. This is a high specification and low cost solution to forced circulation seal support systems. This system cannot be used in an ATEX environment.



Features	Benefits
Uses the same proven technology and modular design as the standard AESSEAL® PUMPPAC™ Range	The PP/SOU™ can be installed in a variety of environments by interchanging the instrumentation options
Specifically designed to be used in a range of non-high corrosive environments	High specification and low cost solution to forced circulation barrier fluid systems
API Plan 54 forced circulation system	Maximises barrier fluid heat dump potential

Label	Description	Purpose
A	Manifold (Aluminium body, 5-50 bar / 72-725 psi)	Securely attaches the motor to the PUMPPAC™ reservoir
B	Motor (Aluminium body, weather proof IP55, 3 phase 0.55 KW 0.79Hp -230/400V-50/60Hz, 4 pole- 1450/1750 rpm)	Drives the pump
C	Pressure gauge (polycarbonate anti-impact body, brass wetted parts)	Displays the pressure of the barrier fluid feeding the mechanical seal
D	Pump (Aluminium construction 3.8 litres / 1.0 gal (US) per minute)	Supplies the barrier fluid to the mechanical seal
E	Pressure control valve (Aluminium construction 5-50 bar / 72-725 psi)	Controls the pressure of the barrier fluid feeding the mechanical seal
F	Suction filter (Carbon steel, 45 litre / 12 gal (US))	Cleans the barrier fluid feeding the mechanical seal
G	PUMPPAC™ reservoir (painted carbon steel 45 litre / 12 gal (US))	Large surface area for barrier fluid cooling to atmosphere

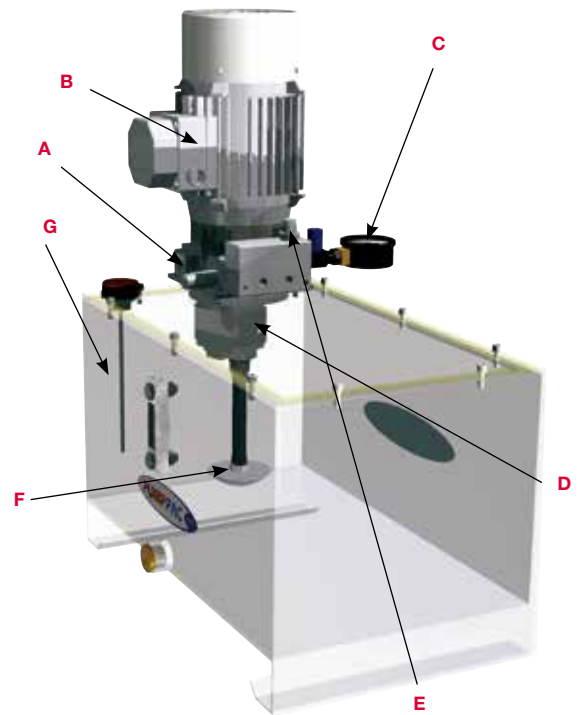

Operating Principle

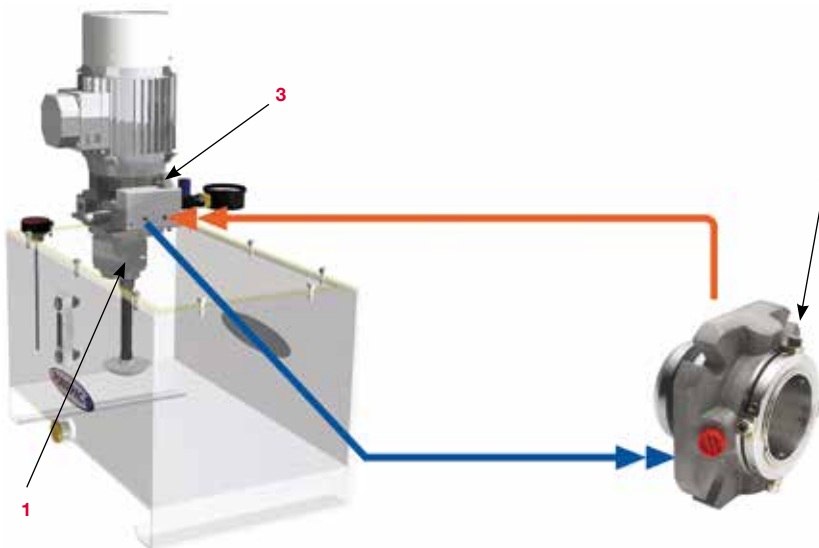

1. Cool Barrier fluid is pumped from the PUMPPAC™ to the mechanical seal.
2. Barrier fluid passes through the mechanical seal and back to the PUMPPAC™ where it is cooled.
3. The back control valve controls the pressure in the line.



PP/01™

The AESSEAL® Oil PUMPPAC™ (PP/01™) is an efficient and high performance forced circulation system.

The product was developed to meet the requirements of the API Plan 54 Piping Plan, which maximizes heat dump potential for the more arduous pump applications. The maximum operating pressure of the standard PP/01™ is 70 bar / 1016 psi.

A fully certified ATEX version of the PP/01™ is now available with a range of optional extras to suit all applications. AESSEAL® also offers a high flow pump option that can generate 12 litres / 3.17 gal (US) per minute (max pressure 35 bar / 508 psi).



Features	Benefits
API Plan 54 forced circulation system	Maximizes barrier fluid heat dump potential
Enhanced modular design to be used on a range of high end applications	The PUMPPAC™ can be installed in a variety of zoned environments by interchanging the instrumentation options
Capable of supplying split flows and a range of pressures for two or more mechanical seals	Barrier fluid cooling of two or more mechanical seals can be accurately controlled

Label	Description	Purpose
A	Pump / motor assembly (Cast iron positive pump, 4 liters / 1.1 gal (US) per minute, Cast iron safe area motor)	This is the heart of the system providing the mechanism for transferring the barrier fluid from the reservoir to the mechanical seal
B	Suction filter	Cleans the barrier fluid as it is removed from the reservoir
C	PUMPPAC™ reservoir: (45 litres / 12 gal (US) capacity, SS construction)	The large volume ensures efficient cooling of the barrier fluid to atmosphere
D	Fill cap	Is the place where the reservoir can be filled with barrier fluid
E	Seal feed	Is the point where the barrier fluid leaves the PUMPPAC™ and travels to the mechanical seal
F	Back pressure control valve (SS construction)	Controls the pressure of the barrier fluid feeding the seal

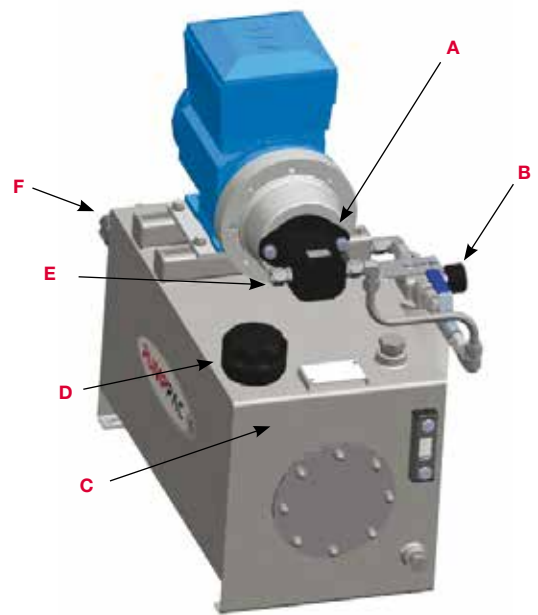

Operating Principle

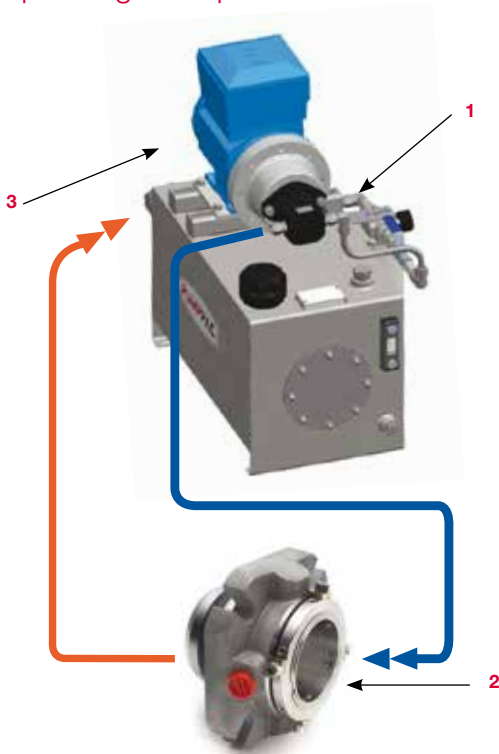

1. Cool barrier fluid is pumped from the PUMPPAC™ to the mechanical seal.
2. Barrier fluid passes through the mechanical seal and back to the PUMPPAC™ where it is cooled.
3. The back control valve controls the pressure in the line.



API Plan Systems

In addition to the company’s extensive range of standard products, AESSEAL® has a dedicated complex systems division.

The division’s research and development team has invested 5,000 man-hours in deciphering the finer details of API 682, ASME VIII Div 1 and PED 2014/68/EU. This dedication has resulted in the design of modular products that guarantee the delivery of high end systems within short lead times.

AES-28™

The design of the AES-28™ vessels is based on a 316 stainless steel, 28 litre / 7.39 gal (US) vessel, which comprises a weld pad level gauge and integral cooling coil as standard. The vessels have a design rating of 45 bar @ 100°C / 652.7 psi @ 212°F. They are designed and manufactured in accordance with a wide range of international specifications.

The AES-28™ range is available with a choice of three vessel options, all of which are held in inventory. This range includes a screwed connection vessel, a socket welded vessel and a butt welded vessel. All three vessel options are fully compliant with API 682. A variety of component options are available to adapt the vessel to specific pump applications. These options include electrical equipment which is supplied as intrinsically safe or flame proof.

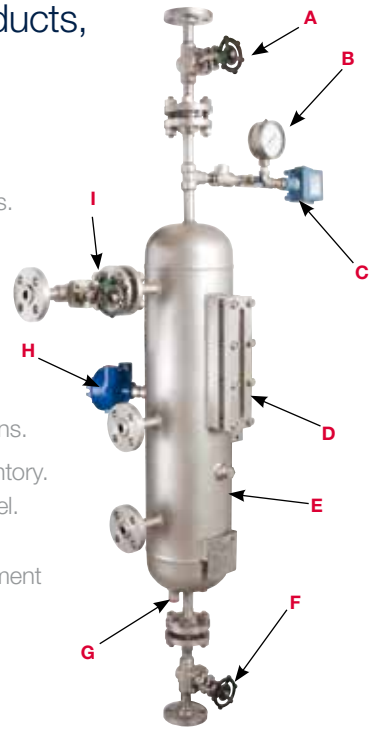

AES-28™ Vessel Options



AES-28™ Vessel with Butt Welded Flanges (Left)
AES-28™ Vessel with Screwed Connections (Right)



AES-28™ Vessel with Socket Welded Flanges (Left)
AES-28-FV™ utilises a bottom flange that can be removed to administer efficient internal cleaning (Right)

Features	Benefits
Designed and manufactured in accordance with ASME V III Div 1 and PED 2014/68/EU	Suitable for a wide range of arduous environments. Design rating of 45 bar @ 100°C / 652.7 psi @ 212°F
316 SS vessel and weld pad construction	Robust vessel suitable for a range of challenging environments
28 litre / 7.309 gal (US) vessel	Large barrier fluid capacity for seal cooling
Modular design	A number of intrinsically safe and EEXD flame proof instrumentation option can be fitted

Label	Description	Purpose
A	Vent valve	Enables easy system venting
B	Pressure gauge	Displays the pressure of the barrier fluid inside the system
C	Pressure switch / Transmitter	Can be used to alarm on high or low vessel pressure
D	Weld pad level gauge (316 SS construction)	Visual indication of liquid barrier fluid level
E	28 litre / 7.4 gal (US) vessel	Large barrier fluid capacity for seal cooling
F	Drain valve	Can be used to drain the vessel
G	Cooling coil connections (Cooling coil supplied as standard with the AES-28)	Cooling coil provides additional cooling of the barrier fluid
H	Level switch / Transmitter	Can be used to alarm on high or low barrier fluid level
I	Fill valve	Can be used to fill / top up barrier fluid

AES-12™

The AES-12™ vessel has been developed to meet the requirements of API 682 with a 12L barrier / buffer reservoir for shaft sizes 60mm (2.5”) and below. The vessel can be used for Plan 52 (un-pressurised) or 53A (pressurised) support systems.



AES-12™ Vessel



API Plan 53B

The AESSEAL® 53B system uses an innovative modular concept to facilitate efficient stock control enabling rapid delivery times. This highly versatile design concept enables bespoke 53B systems to be produced tailored to customer specific needs.

The system pipe work is constructed from 316 stainless steel pipe work to offer resistance to a range of arduous environments. This system design is suitable for 66 bar @ 100°C / 957.25 psi @ 212°F. This system design is fully API 682 compliant and is available with a variety of component options. These options include electrical equipment which are supplied as intrinsically safe or flame proof.

Features	Benefits
Compact design	The small footprint of the product enables its installation in areas with restricted space
Low centre of gravity	Allows a variety of larger accumulator options to be applied within the modular design. Designed to take into consideration the details of API 682 4th Edition
Lifting eye	Enables efficient and safe lifting of the product
Earthing boss	Enables efficient and safe electrical earthing of the product
Paint work suitable for on & offshore	Every 53B system is suitable for the environment in which it is installed
Export quality packaging is standard	AESSEAL® understands the importance of secure and effective packaging and guarantees that all customers will receive fully protected product to their sites

Label	Description	Purpose
A	Bladder accumulator	Maintains barrier fluid pressure to the inboard and outboard seal faces
B	Non-return valve	Maintains system pressure during filling and ensures top up systems do not become contaminated
C	Drain valve	Can be used to drain the vessel
D	Seal feed & return	Supplies barrier fluid to and from the mechanical seal
E	Fill valve	Can be used to fill / top up barrier fluid
F	System cooler	Dissipates the heat of the barrier fluid, a variety of cooler types are available
G	Double block and bleed valves	Enables easy isolation and draining of the system instrumentation
H	Pressure switch / Transmitter	Can be used to alarm on high or level vessel pressure
I	Pressure gauge	Displays the pressure of the barrier fluid inside the system
J	Vent valve	Enables easy system venting
K	System stand	Supports the system components and is painted to the AESSEAL® offshore paint specification to withstand a range of industrial environments

*Transmitters also available

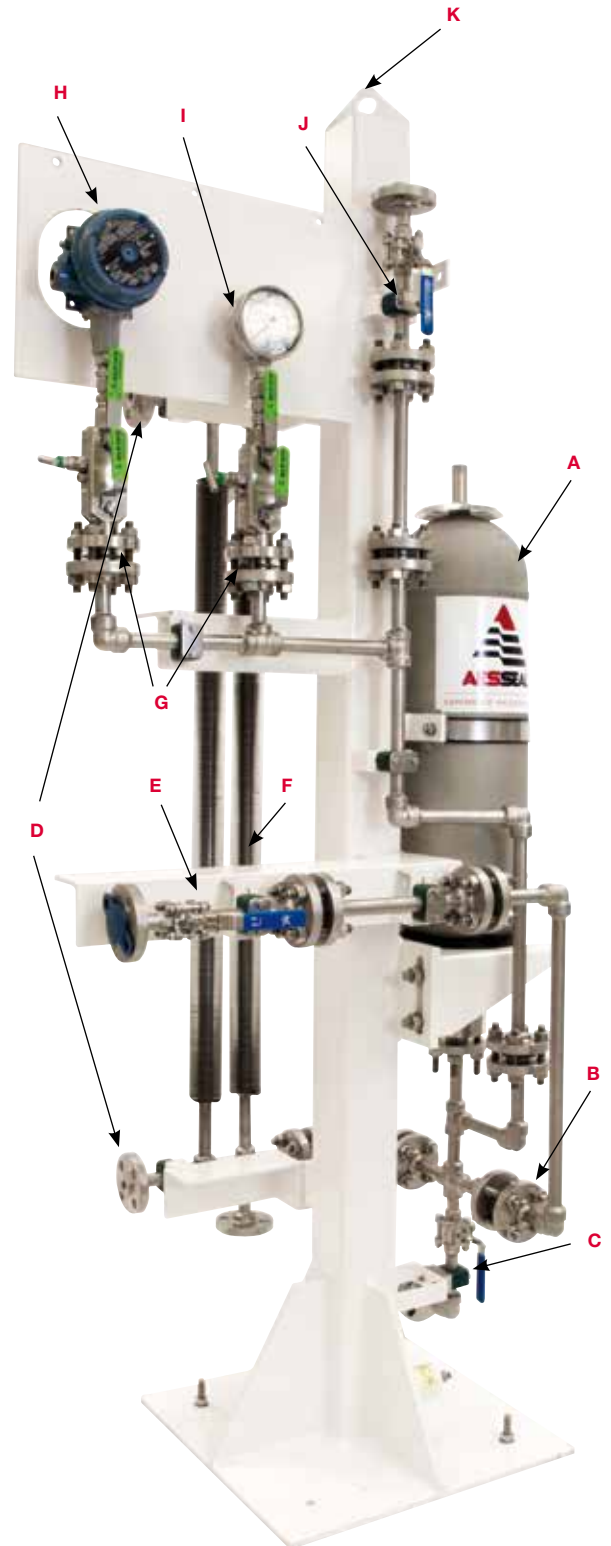
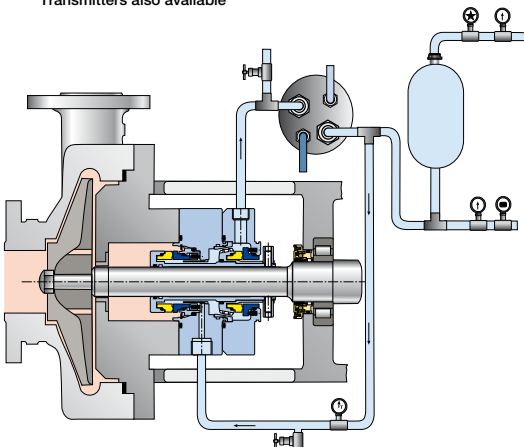

Additional Piping Plans

Below are only a few examples of the various API Plans that are available. Contact the AESSEAL® complex systems division for quotes and more information.



API Piping Plan Booklet

API Plan 75

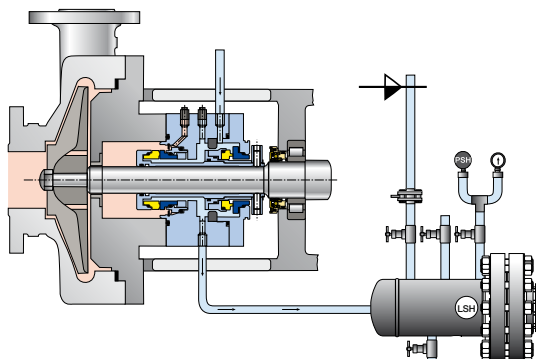

API Plan 76

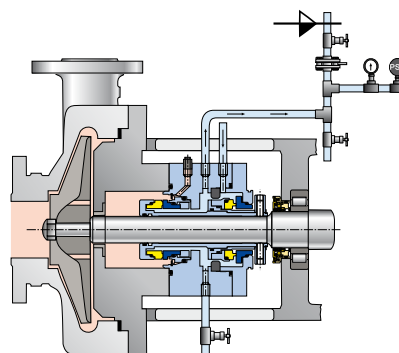

API Plan 65

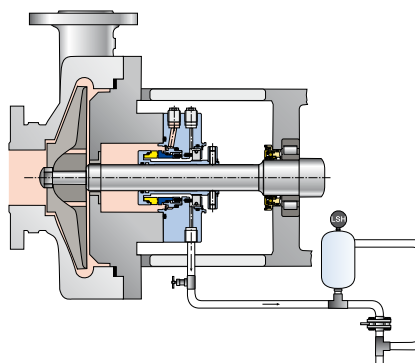

Compact 107™



The Compact 107™ is an innovative AESSEAL® specific design that combines the benefits of API Plans 53A, 53B and 54. The system can be used to supply pressurised barrier fluid to a number of seals.

Gas Panel

The Gas Panel system is designed to supply inert gas (e.g. Nitrogen) to mechanical seals on processes that cannot tolerate contamination by water or oil barrier fluids.

The self contained systems (Images 1 and 2) has a maximum inlet pressure of 14 bar / 203 psi and a maximum outlet pressure of 10 bar / 145 psi enabling it to be used on a wide range of applications. A high pressure 21 bar version (stainless steel) is also available instrumented

Features	Benefits
Coalescing filter	Ensures that a clean gas supply is feeding the seal
Components are enclosed in a secure cabinet (this does not apply to the stainless steel versions)	Protects the components from the industrial environment
Non-return valve	Prevents product contamination of the gas panel during upset conditions
Dual flow indicators	Allows primary flow indication and secondary alarm condition



Standard Gas Panel
Image 1



Stainless Steel Gas Panel
Image 2

Label	Description	Purpose
A	Ball valve	Valve can be closed to isolate the gas panel system to enable maintenance to be carried out
B	Check valve	Protects the gas supply from process contamination
C	Coalescing filter	Cleans the gas supply to the seal
D	Pressure regulator	Regulates the pressure of the gas barrier feeding the seal (10 bar / 145 psi maximum output pressure)
E	Flow meter (high)	Displays the flow rate of gas feeding the seal
F	Flow meter (low)	Displays the flow rate of gas feeding the seal
G	Pressure gauge	Displays the pressure of gas feeding the seal
H	Pressure switch*	Will warn of problems with the gas pressure
I	Flow limit switch*	Alarms in the event of excess Nitrogen flow indicating seal failure

Standard Gas Panel Schematic

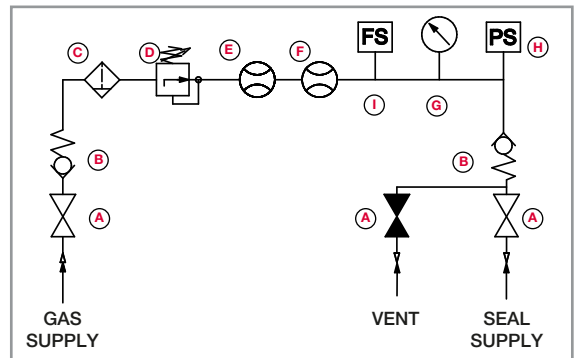

Compressor Dry Gas Seal Support Systems

High quality compressor dry gas seal support systems engineered to customer requirements for all seal configurations and applications. Each AESSEAL® gas conditioning system contains the key API modules plus various enhancements derived from our own field experience, to ensure the highest degree of compressor dry gas seal reliability and longevity.

For every application AESSEAL® performs a detailed phase analysis in-house to determine the required level of gas conditioning.

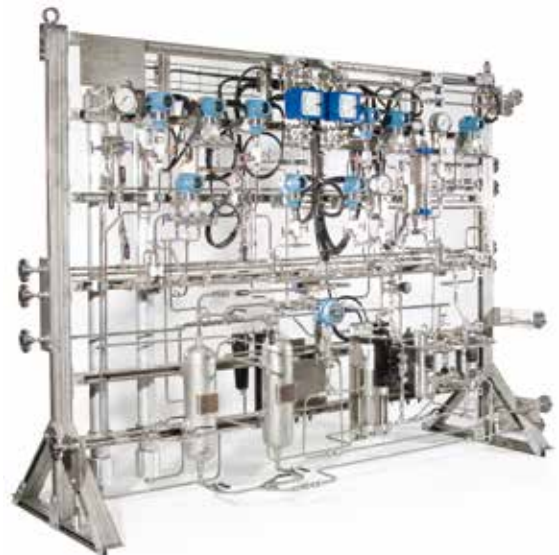

SMART TRACK®

Designed to track and maintain a constant differential with fluctuations in process pressure.

Patent pending isolating pressure tracking valve that will maintain a positive differential pressure between a reference input pressure (seal chamber / vessel pressure) and an output pressure (typically API Plan 53A) with the connection of a suitable supply (Typically nitrogen at a pressure greater than maximum operating barrier pressure). The device has an integrated isolation unit that will provide a physical barrier between product (seal chamber / vessel fluid) and the device.

Features	Benefits
Self regulating	Tracks pressure to maintain an optimum double seal environment
Quick response	Transient and upset conditions handles with ease
Simplicity	A compact alternative to complex seals & systems
Factory set	No operator intervention required. Unit is supplied pre-set
Ergonomic	Simple in line connection and mounting

Label	Description	Purpose
A	Input reference line / pressure	Variable pressure source
B	Gas venting	Depressurisation connection - pipe to safe area
C	Gas supply	Pressurisation connection - from a higher pressure source i.e. N ₂ gas bottle or ring main
D	Outlet regulated pressure (to top up vessel)	Connection to vessel
E	Alternative input reference line / pressure	Vent plug to remove air from reference line

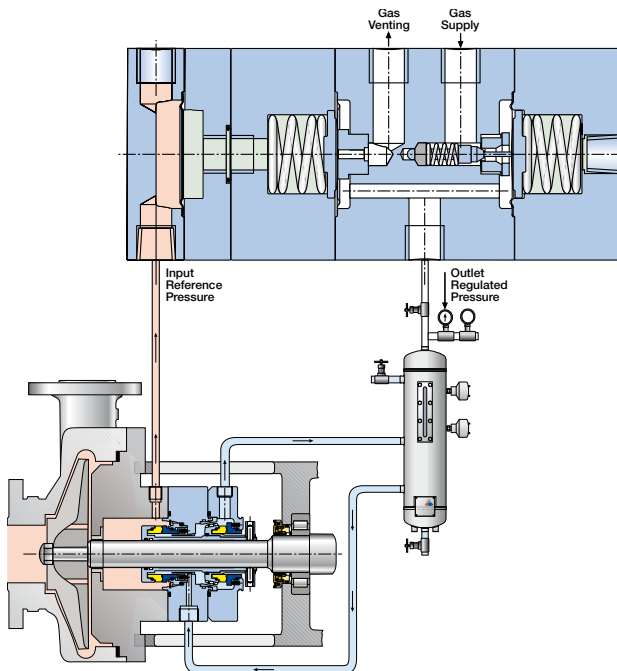
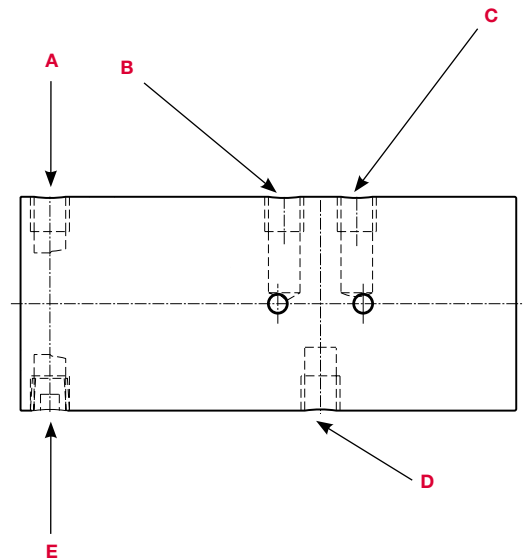

SMART TRACK II™

Patent pending variable back pressure valve. A unique & simple pressure tracking solution designed to track and maintain a constant differential with fluctuations in process pressure.

Pressure tracking valve that will maintain a positive pressure differential between a reference input pressure (seal chamber) and an regulated barrier system back pressure (typically API Plan 54). The device has the option to fit an integrated isolation unit that will provide a physical barrier between product (seal chamber) and the active area of the device.

Features	Benefits
Self regulating	Tracks pressure to maintain an optimum double seal environment control
Factory set	No operator intervention possible, unit is supplied factory set
Quick response	Transient and upset conditions handled with ease
Reliability	Optimum mechanical seal conditions maintained in operation and upset conditions
Cost effective	Replaces complex control systems and over engineered solutions

Label	Description	Purpose
A	Input reference line / pressure	Variable pressure source
B	Fluid circulation port inlet	Circulation connection from seal
C	Fluid circulation port outlet (to tank)	Circulation connection to tank
D	Factory set plug fluid chamber	Vent pressure transfer fluid seal - do not remove
E	Factory set plug	Vent plug to remove air from reference line
F	Bias spring (option available)	To set constant differential above reference pressure (A) 2bar (29psi), 4 bar (58psi) or 6 bar (87psi) available

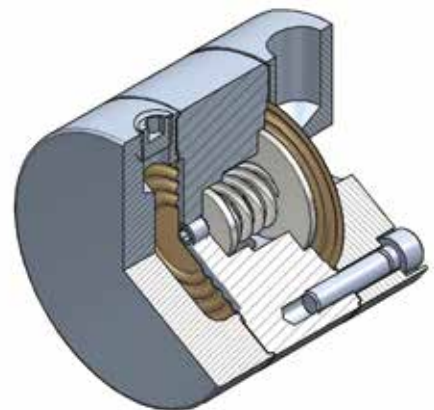
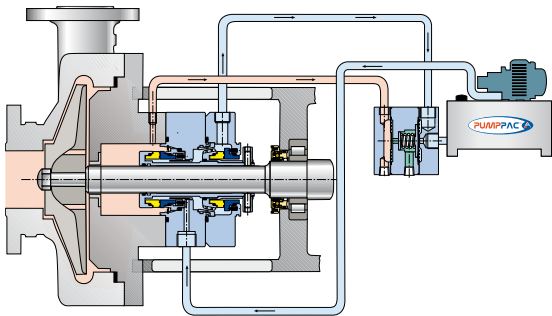
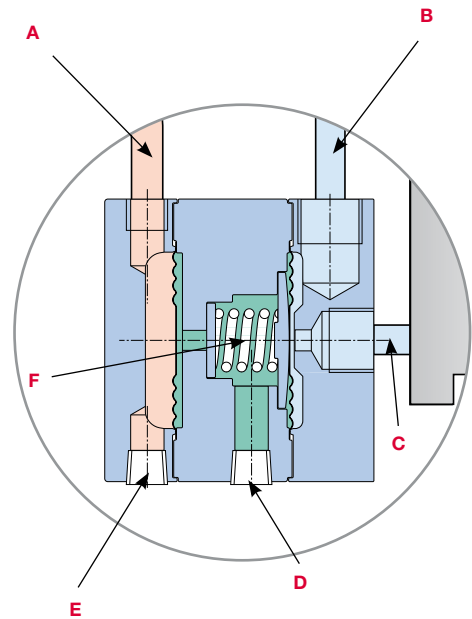

SMART TRACK II™ Schematic With PUMPPAC™

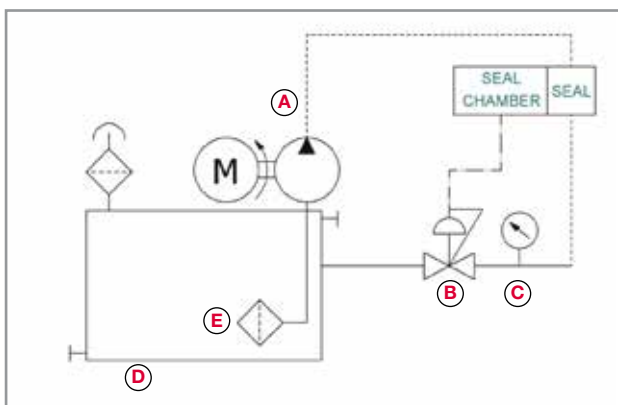

Item	Description
A	PUMPPAC™ pump
B	SMART TRACK II™
C	Pressure gauge
D	PUMPPAC™ reservoir
E	Suction filter



Top Up Trolley

The TUP100™ are 100 litre (26 US gals) mobile barrier fluid Top Up Trolleys.

The units are offered in Stainless Steel to suit the vast majority of industrial applications. The TUP100™ comes with 6m (20ft) of hydraulic flexible hose and include a hand pump and instrumentation pack that is rated to 42 bar (610 psi). The product is primarily designed to satisfy the needs of the oil and gas industry.

Features	Benefits
Full stainless steel construction	Modular system for practically all commonly used barrier fluid media
Hand pump delivery	Reliable and robust filling operation
Mobile unit with integral breaking system	Operator friendly

Label	Description	Purpose
A	Framework	Stainless framework, to allow manoeuvring and steering
B	Tank	Fluid reservoir, nominally 100
C	Pressurising pump	Hand Pump suitable up to 42barg
D	Pressure gauge	Display supply pressure (optional)
E	Reservoir filler vent cap	Reservoir fill and vent cap
G	Hose	6 meter (20ft) flexible hydraulic hose to connect top-up unit to system
F	Quick release coupling	To allow quick, easy manual connection and disconnection of the supply hose (optional)

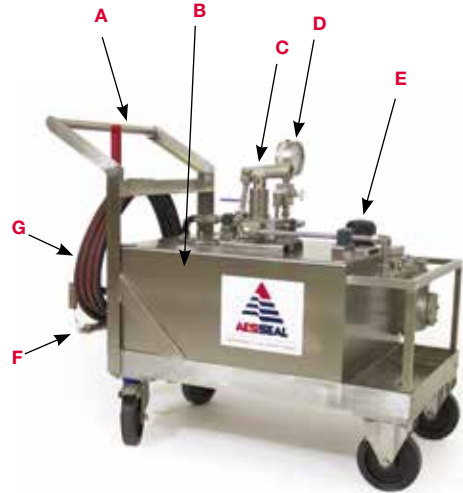

AESSEAL® Plan 53B seal support system being filled / topped up by the TUP100™



Cooler Options

Liquid - Helicoil Cooler

The AESSEAL® Cooler is constructed from 316 stainless steel tube and cast iron casing (cast steel & cast 316 steel casting options available).

This robust product is a very efficient seal cooler used on API Piping Plan 21, 22 and 23 arrangements. The product can also be used in conjunction with other products in the systems division range to provide additional cooling on high heat applications.



AES-CIC Cooler

The AES-CIC Cooler is an efficient yet simple product that provides cost effective seal cooling.

The AES-CIC is a new coiled double pipe water cooler offered as standard in 316L stainless steel, to be used where cooling water is readily available. The AES-CIC is designed to be utilised horizontally or vertically, allows for ease of installation. The cooler is suitable for API Piping Plan 21, 22 and 23 arrangements and in conjunction with products in the system division range to provide additional cooling on high heat application.



AES682C™

Robust design high efficiency cooler. The AES682C™ is a full stainless steel shell & tube heat exchanger, with an innovative dual concentric tube coil for cooling mechanical seal barrier / buffer / flush fluids. Typically uses plant cooling water on shell side and hot barrier / buffer / flush fluids on the tube side. This product can also be easily dismantled for ease of cleaning and maintenance. Suitable for a wide range of arduous environments.



AES682C™ Internal

AES682C™ Shell

Air Blast Cooler

The Air Blast Cooler uses a combination of high performance cooling elements and high capacity, compact AC electrically powered fans to give long trouble-free operation in arduous applications. The compact design provides the highest cooling performance in heat dissipation whilst minimizing the space required.

- Cooling range 0-5 kW
- AC motors in 230 / 400 Volt 50 / 60 Hz
- Maximum working pressure 16 bar / 232 psi
- Also available with ATEX Zone 1 Antistatic Exd motor



Convection - Finned Tubing

Finned tubing provides additional convection cooling on high heat applications. The tubing is constructed from 316 SS schedule 40 pipe with aluminium wound fin and 316 SS turbulator. It is available in banks of 2 and 4 depending on the amount of heat that needs to be removed. Butt and socket weld flanges are available for each bank option.



Finned Tubing Cross Section



Finned Tubing

Python™

The AESSEAL® Python is an advanced air cooled heat exchanger for cooling mechanical seal barrier/buffer/flush fluids. Air cooling is achieved through natural convection without the need for cooling water. The unit consists of a tube formed into a coil, terminated with inlet and outlet manifolds. The Python is available in both 8m single (Figure 1) and 16m dual coil (Figure 2) arrangements.



Figure 1
Single Coil

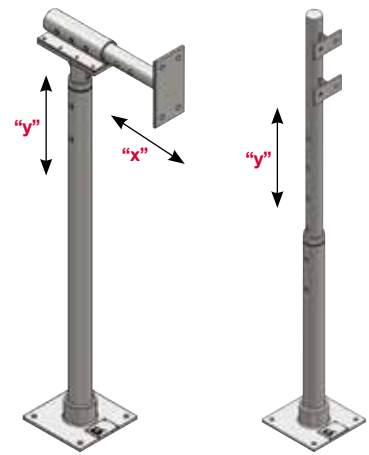

Figure 2
Dual Coil

Optional Extras

Vessel Options

- Mounting stand - Standard and telescopic options
- Level switch - Safe area, intrinsically safe and explosion proof options
- Pressure switch - Safe area, intrinsically safe and explosion proof options
- PTFE lined braided flexible hose kit - SS construction
- Hard pipe kit - SS construction
- Finned tubing kit - Includes all necessary connections
- In-line water filter kit - Includes all necessary connections
- Cooling coil - 316 SS construction
- Hand pumps - Water and oil options
- Air / Nitrogen supply regulator - Zinc alloy construction / SS option
- Vessel kits - Consists of a vessel and decals only
- Top up Trolley - For use on systems pressurised by an external gas supply
- Pressure gauge - All SS option



XY and Y Telescopic System Stands

Plan 53B Insulation Jacket

The Plan 53B Insulation Jacket reduces the temperature fluctuations of 53B vessels, often caused by diurnal and/or seasonal changes. It is also highly effective in applications wherein the vessel is exposed to solar radiation.

By reducing these fluctuations it provides two key advantages:

- It allows a more accurate pressure reading to be taken, and thus more accurate fill levels to be obtained.
- It reduces the differential pressure between the product and system pressures, increasing seal life.



PUMPPAC™ Options

- ATEX certified oil PUMPPAC™
- Explosion proof motor - Cast iron construction and ATEX certified
- Top entry low level switch - Safe area, intrinsically safe and explosion proof options
- High / Low pressure switch - Safe area, intrinsically safe and explosion proof options
- Back pressure valve - SS construction
- Suction filter - SS construction
- Flow divider - Splits the flow to feed multiple mechanical seals (the amount of seals that can be fed depends on the model of PUMPPAC™ being used, please consult your local AESSEAL® representative for more information)
- High flow oil pump - For use on oil PUMPPAC™ only
- Pressure gauge - SS construction



PUMPPAC™

Gas Panel Options

- Pressure switch - Safe area, intrinsically safe and explosion proof options
- Flow switch - Intrinsically safe & explosion proof option



EExd Pressure Switch

ICEGUARD™

The AESSEAL® ICEGUARD™ is ideal for commercial and industrial applications where water is prone to freeze in and around the seal support system.

The ICEGUARD™ continually senses the temperature of the water inside the seal support system. When the water temperature approaches freezing, and freeze damage is imminent, the thermal actuator modulates the valve open. When the makeup water temperature returns to the safe range, the valve then modulates closed, minimizing water loss. The flow generated prevents the liquid inside the system from freezing.

The ICEGUARD™ is designed to be:

- Self automated
- Installed on the system and ignored
- Free from electronics
- Provide 24/7 freeze protection 365 days per year

The ICEGUARD™ comes as a 2 piece product.

- The first protects the closed loop system to and from the mechanical seal from freezing
- The second protects the water feed line into the vessel from freezing



With both installed correctly, the ICEGUARD™ will offer effective freeze protection to the entire seal support system.

Heat Guard

Industrial applications are hazardous places for personnel to work especially when hot oil seal support vessels are in use. Health and Safety Regulations stipulate that protective clothing and guarding should be provided where objects with surface temperatures greater than 50°C (122°F) are present.

The AESSEAL® Heat Guard is ideal where SP range (eg. SSE12) and AES-15 vessels are in use at temperatures greater than the health and safety limit. Fitted to the vessel the Heat Guard remains 40°C (104°F) cooler than the vessel body and so ensuring that site personnel cannot injure themselves by accidentally touching the dangerously hot vessel body.

Retrofittable design allows it to be installed onto vessels currently in operation once they have cooled to a temperature that is safe to touch.



Standard Seal Support Systems Order Coding Guide

The systems division has established a new order code guide to simplify the process of ordering a standard seal support system. The new codes ensure that customers order the exact product they require and remove the need for developing AZA or MZM System codes when ordering products with optional extras. Please see the tables below for details of old stock codes, the new stock code and an explanation of how to form the new stock code.

OLD STOCK CODE	NEW STOCK CODE	OLD STOCK CODE	NEW STOCK CODE
VSE/SP02	VSE/P212--SA----A-	VSE/SP02-25 <i>With explosion proof low level switch</i>	VSE/P212--SAEC--A-
VSE/SW02	VSE/W210--SA----A-	VSE/SP02-SS <i>(US) Fully stainless components</i>	VSE/P212SS---F-
VSE/SW02-25	VSE/W225--SA----A-	VSE/SW3-25 <i>With safe area pressure switch and stand</i>	VSE/W325--SAS-A-GA
VSE/SW03-25-CC-US	VSE/W325CCSA----H-		

SYSTEM CODE (1-3)

This refers to the type of vessel a customer will be using with the seal support system. All standard systems use a 10, 12 or 25 litre SSE type vessel so please enter VSE for this part of the order code.

SYSTEM TYPE (5-6)

This defines the type of system a customer needs, i.e. P2 for a standard gas pressurised system, W2 for a standard water management system or WC for a condensate system.

P1	=	Buffer systems for use with oil and water (See page 20)
P2	=	Gas pressurised system (See page 20)
P3	=	Gas pressurised system with the addition of finned tubing for high heat applications (See page 20)
W2	=	Standard water management system using plant water line as water and pressure source (See page 15)
W3	=	Standard water management system using plant water line as water and pressure source with addition of finned tubing for high heat applications (See page 15)
WF	=	Flow Fuse™ water management system (See page 16)
WM	=	Low cost water management system utilizing the full pressure in the plant water line (See page 14)
WP	=	Low cost water management system, with weld pad level gauge, utilizing the full pressure in the plant water line (See page 14)
WC	=	Water management system specifically designed for condensate applications (See page 17)

VESSEL SIZE (7-8)

Relates to the capacity of the vessel a customer is ordering. Please note that with W2, W3, WM & WP type systems, 10 litres is the standard, but with P1, P2 & P3 type systems the 12 litre weld pad is the standard.

10	=	White powder coat finish as standard, no weld pad level gauge
12	=	Shot bead blast finish and integral weld pad level gauge as standard
15	=	Shot bead blast finish, integral weld pad and cooling coil as standard (option for WC system only)
25	=	There are 2 options available (type of system will determine the option used)

1. White powder coat with no weld pad level gauge
2. Bead blast with integral weld pad level gauge

COOLING COIL (9-10)

Add **CC** when ordering a system incorporating a cooling coil

COMPONENT MATERIAL (11-12)

When ordering a system with standard component configurations, please choose SA. If it is to be a fully stainless system (all components in stainless steel), then please chose SS (only available for W2, W3, P1, P2 & P3 systems). Please note that when ordering a SS system it will be supplied with braided hose as standard, therefore when ordering a SS system, please choose option E or F in the **hose option section**.

SA	=	System with standard components
SS	=	System with fully stainless components (only an option on W2, W3, P1, P2 & P3 systems)

New Stock Code Explanation

System code				Type		Size		Cooling		Material		Inst	Level	Pressure	H/Pump	Hose	Stand
1	2	3	4	5	6	7	8	9	10	11	12	13	14	15	16	17	18
V	S	E	/	P	2	1	2	-	-	S	A	-	-	-	-	A	-
V	S	E	/	W	2	1	0	-	-	S	A	-	-	-	-	A	-
V	S	E	/	W	2	2	5	-	-	S	A	-	-	-	-	A	-
V	S	E	/	W	3	2	5	C	C	S	A	-	-	-	-	H	-
V	S	E	/	P	2	1	2	-	-	S	A	E	C	-	-	A	-
V	S	E	/	P	2	1	2	-	-	S	S	-	-	-	-	F	-
V	S	E	/	W	3	2	5	-	-	S	A	S	-	A	-	G	A

INSTRUMENT PROTECTION (13)

Relates to site preferences in terms of the hazard level where electrical equipment will be installed.

- S** = Safe area
- E** = Explosion proof
- I** = Intrinsically safe

LEVEL SWITCH OPTIONS (14)

- A** = Safe area low level switch
- B** = Safe area high / low level switch
- C** = Explosion proof low level switch (flame proof, zone 1 & division 1, ATEX certified)
- D** = Intrinsically safe high / low level switch (can be incorporated in an intrinsically safe circuit ATEX certified)

PRESSURE SWITCH OPTIONS (15)

- A** = Safe area high / low pressure switch (standard range 0-10 bar / 0-145 psi)
- B** = Explosion proof high / low level pressure switch (flameproof, zone 1 & division 1, ATEX certified)
- C** = Intrinsically safe high / low pressure switch (can be incorporated in an intrinsically safe circuit, ATEX certified)

HAND PUMP OPTIONS (16)

- A** = Oil hand pump - can only be used with oil
- B** = Water hand pump - can be used with water and oil

HOSE OPTIONS (17, 1 Kit = Supply & return hose & fittings)

- A** = Nylon hose kit (12mm) supplied with seal fittings
- B** = Nylon hose kit (1/2") supplied with seal fittings for US specification systems
- C** = SS hard pipe kit, 2 of 58" / 1.5m lengths of 12mm hard pipe and seal fittings
- D** = SS hard pipe kit, 2 of 58" / 1.5m lengths of 1/2" hard pipe and seal fittings for US specification systems
- E** = SS braided flexible hose kit - 1 x 42" and 1 x 48" of 12mm stand pipe braided hose and seal fittings
- F** = SS braided flexible hose kit - 1 x 42" & 1 x 48" of 1/2" stand pipe braided hose and seal fittings for US specification systems
- G** = Finned tube kit - 2 off lengths of finned tube supplied with seal and vessel fittings (12mm)
- H** = Finned tube kit - 2 off lengths of finned tube supplied with seal and vessel fittings (1/2") for US specification systems

MOUNTING STAND (18)

- A** = Standard Systems Stand 304 SS
- B** = Telescopic Y stand in carbon steel painted (vertical orientation of the stand can be adjusted)
- C** = Telescopic XY stand in carbon steel painted (vertical and horizontal orientation of the stand can be adjusted)
- D** = Telescopic Y stand in 304 SS (vertical orientation of the stand can be adjusted)
- E** = Telescopic XY stand in 304 SS (vertical and horizontal orientation of the stand can be adjusted)



EXPERIENCE THE EXCEPTIONAL

To experience the exceptional, please contact your local representative. Discover full details on our website:

www.aesseal.com

For further information and safe operating limits contact our technical specialists at the locations below.



Use double mechanical seals with hazardous products.

Always take safety precautions:

- Guard your equipment
- Wear protective clothing



WARNING

UK Sales & Technical advice:

AESSEAL plc
Mill Close
Bradmarsh Business Park
Rotherham, S60 1BZ, UK
Tel: +44 (0) 1709 369966
Fax: +44 (0) 1709 720788
E-mail: seals@aesseeal.com
www.aesseal.com

AESSEAL plc is certified to ISO 9001, ISO 14001,
ISO 29001, ISO 50001 and OHSAS 18001.

'Our purpose is to give our customers such exceptional service that they need never consider alternative sources of supply.'



USA Sales & Technical advice:

AESSEAL Inc.
355 Dunavant Drive
Rockford,
TN. 37853, USA
Tel: +1 865 531 0192
Fax: +1 865 531 0571
E-mail: usa@aesseeal.com
www.aesseal.com

Important: Since the conditions and methods of use of this product are beyond our control, AESSEAL plc expressly disclaims any and all liability resulting or arising from any use of this product or reliance on any information contained in this document - AESSEAL plc standard conditions of sale apply. All sizes are subject to manufacturing tolerances. We reserve the right to modify specifications at any time. AESSEAL® is a Registered Trademark of AES Engineering Ltd, AESSEAL plc recognizes all trademarks and trademark names as the property of their owners.